

KINTEK

KINTEK srl
Via Goretta 88/G 10072 Mappano Fraz. di Caselle (TO) ITALIA
tel. +39.011.9968065 fax +39.011.9965662
<http://www.kintek.it> e-mail: info@kintek.it



KINTEKS Hauptfzrziel ist die Verbesserung der dem Kunden angebotenen Leistungen und Produkte, um dessen Zufriedenheit zu erhohen sowie die Handelsgeschafte in den verschiedenen National- und Internationalmarkte zu erweitern.

Zu diesem Zweck verpflichtet sich KINTEK, Folgendes zu verfolgen, zu gewahren und zu verbessern:

- Die Einhaltung von gesetzlichen und technischen Anforderungen in Bezug auf die gelieferten Produkte (mittels einer standigen Fortbildung des Personals durch Teilnahme an Messen und betriebsinterne Kurse);
- Die Einhaltung der expliziten Anfragen des Kunden, indem eine hochprofessionelle und stark qualifizierte Handelsabteilung fur den Innen- und Auenmarkt im Bereich des mechanischen Werkzeugs zur Verfugung steht;
- Die Einhaltung der impliziten Anfrage des Kunden durch eine kritische Analyse der erhaltenen Bestellungen und der gesendeten Angebote, durch eine regelmaige und haufige uberprufung der Liefertermine und durch direkte Kundenbesuche;
- Dienstleistung durch die Erfahrung des eigenen Personals;
- Die Reklamationsfuhrung und die Leitung der eventuellen Nichtubereinstimmungen in Bezug auf die Endprodukte und auf die Betriebsverfahren;
- Standige Fortbildung im technischen und informatischen Bereich.

Solche Tatigkeiten basieren auf folgende Prinzipien:

- Verwicklung des ganzen internen und externen Betriebspersonals in die Qualitat;
- Erkennen der Betriebsverfahren, die die Kundenzufriedenheit beeinflussen und Bestimmung der Ausfuhrungs- und uberprufungswege;
- Entwicklung der Forschungstatigkeiten fur die Verfahrungsleitung, welche die Qualitat der Dienstleistung bzw. des gelieferten Produkts beeinflusst;
- Analyse und standige uberwachung der Verfahren, um die Verbesserungsspannen zu bestimmen.

Die obengenannten Prinzipien werden durch die folgenden operativen Modalitaten entwickelt:

- Entwurf und Implementierung von einem Leitungssystem fur die Qualitat, das gema der Normen UNI EN ISO 9001:2000 bescheinigt wird; Vorbereitung (in diesem System) von spezifischen uberwachungstatigkeiten und Verbesserung der Verfahren, die die Kundenzufriedenheit beeinflussen.



KINTEK 's main long-term target is the improvement of the services and products offered to the customers, in order to increase their satisfaction and the commercial activity in the various national and international markets.

In order to achieve these targets, KINTEK must pursue, ensure and improve the following:

- The observance of the law and technical requirements about the supplied products (with a staff's constant updating through exhibitions and company courses);
- The satisfaction of the customer's explicit requests (by means of a commercial office for the foreign and italian market, with high competence and stronger and stronger experience in the field of mechanical tooling);
- The satisfaction of the customer's implicit requests (considering the received orders or the sent offers critically, checking periodically and frequently the observance of deliveries to the customer, also visiting the customer directly);
- The service provided by the staff's experience;
- The management of claims and possible faulty products (for both manufactured goods and internal industrial processes);
- The constant updating in the technical and computer field.

These activities are based on the following principles:

- Internal and external staff's involvement in quality;
- Identification of the industrial processes that condition the customer's satisfaction and definition of the ways to perform and check these processes;
- Research development in the field of quality of service and/or manufactured goods;
- Constant analysis and control of the processes in order to find the margins of improvement.

The above mentioned principles will be developed according to the following operating procedures:

- Planning and implementation of a Quality System certified according to the UNI EN ISO 9001:2008 Norms Arrangement, in this system, for specific control and improvement of the processes that determine the customer's satisfaction.



Основной целью компании KINTEK в долгосрочных отношениях с клиентами – улучшение сервиса и продукции, которую мы предлагаем, для удовлетворения требований наших клиентов, а также для увеличения продаж на национальном и международном рынках.

Для достижения поставленной цели KINTEK осуществлять, гарантировать и улучшать следующее:

- Соблюдение законов и технический требований к поставляемой продукции (сотрудники компании должны постоянно изучать эти пункты на выставках и курсах)
- Удовлетворение четко поставленных требований клиентов (с помощью офиса продаж на зарубежный и итальянский рынки, где работают квалифицированные сотрудники, и с помощью накопления все большего опыта в области механообработки)
- Удовлетворение неясных требований клиентов (проверяя все заказы, получаемые от клиентов, тщательная подготовка коммерческих предложений клиентам, проверяя периодически отгрузки клиентам, посещение клиентов)
- Сервис, предлагаемый опытными профессионалами
- Устранение жалоб и возможно бракованной продукции (проверяя саму продукцию и процесс ее изготовления)
- Постоянное улучшение технических и компьютерных навыков персонала

Эти действия основаны на следующих принципах:

- Вовлечение персонала в решение вопросов качества продукции
- Идентификация промышленных процессов производства для удовлетворения клиентов, влияние на процессы производства и контроль над ними
- Постоянное развитие в области качества сервиса и/или предлагаемой продукции
- Постоянный анализ и контроль над процессами производства для поиска решений по его улучшению

Эти действия основаны на следующих принципах:

- Планирование и внедрение системы качества в соответствии с UNI EN ISO 9001:2008.

Соответствие качества нашей продукции данному стандарту говорит об удовлетворении всех нужд клиентов.



Le but principal à long terme de la KINTEK est celui d'améliorer les services et les produits offerts au client pour augmenter la satisfaction du client même et la couverture commerciale dans les différents marchés nationaux et internationaux.

À cette fin, KINTEK s'engage à poursuivre, garantir et améliorer:

- Le respect des conditions requises au niveau législatif et technique par rapport aux produits fournis (grâce à une formation permanente du personnel obtenu à travers la participation aux foires commerciales et à travers des cours internes);
- Le respect des demandes explicites du client (mettant à disposition une division commerciale très professionnelle et très qualifiée pour le marché étranger et italien et avec une expérience consolidée dans le domaine de l'outillage mécanique);
- Le respect des demandes implicites du client (à travers une analyse critique des ordres reçus ou des offres envoyés, à travers un contrôle régulier et fréquent du respect des délais de livraison au client et à travers des visites directes chez le client);
- Le service grâce à l'expérience du personnel;
- La gestion des plaintes et la gestion des non-conformités par rapport aux produits finaux et aux procédés d'entreprise;
- Formation continue dans le domaine technique et informatique.

Ces activités sont basées sur les principes suivants:

- Participation du personnel interne et externe envers la qualité;
- Identification des procédés d'entreprise qui influencent la satisfaction du client et définition des modalités d'exécution et contrôle de ces procédés;
- Développement des activités de recherche pour la gestion des procédés qui influencent la qualité du service et/ou du produit fourni;
- Analyse et supervision continue des procédés afin de déterminer les marges d'amélioration.

Les principes ci-dessus seront développés à travers les modalités opérationnelles suivantes:

- Conception de projet et mise en œuvre d'un système de management de la qualité qui est certifié selon la norme UNI EN ISO 9001:2000;
- Prédisposition (dans ce système) des activités spécifiques de contrôle et amélioration des procédés qui influent sur la satisfaction du client.



L'obiettivo che la KINTEK intende perseguire e garantire nel tempo è il miglioramento dei servizi e dei prodotti offerti al cliente per aumentare la soddisfazione del cliente stesso e aumentare la copertura commerciale nei vari mercati nazionali ed internazionali.

La KINTEK per raggiungere ciò, si impone di perseguire, garantire e migliorare:

- Il rispetto dei requisiti sia di legge che tecnici relativi ai prodotti forniti (mediante un continuo aggiornamento del proprio personale ottenuto tramite partecipazione a fiere, e a corsi interni);
- Il rispetto delle richieste esplicite del cliente (mettendo a disposizione un ufficio commerciale per il mercato estero e Italia, di elevata professionalità e con un'esperienza che è sempre più consolidata nel settore della utensileria meccanica);
- Il rispetto delle richieste implicite del cliente (mediante un'analisi critica degli ordini ricevuti o dell'offerte inviate, mediante un controllo periodico e frequente sul rispetto delle consegne al cliente, mediante visite dirette presso il cliente);
- Il servizio attraverso l'esperienza del proprio personale;
- La gestione dei reclami e delle eventuali non conformità riscontrate (sia relative al prodotto finito che ai propri processi aziendali);
- Il continuo aggiornamento in campo tecnico e informatico.

Tali attività si fondano sui seguenti principi:

- Coinvolgimento di tutto il personale aziendale interno ed esterno verso la qualità;
- Individuazione dei processi aziendali che influenzano la soddisfazione del Cliente e definizione delle modalità di esecuzione e controllo di tali processi;
- Sviluppo delle attività di ricerca finalizzate alla gestione dei processi che influenzano la qualità del servizio e/o prodotto fornito;
- Analisi e monitoraggio continuo dei processi allo scopo di identificare i margini di miglioramento.

I principi individuati saranno sviluppati attraverso le seguenti modalità operative:

- Progettazione ed Implementazione di un Sistema di Gestione per la Qualità certificabile ai sensi delle Norme UNI EN ISO 9001:2008

Prédisposition, nell'ambito del sistema, di specifiche attività di monitoraggio e miglioramento dei processi che influenzano la soddisfazione del Cliente.



KINTEK 的主要长期目标是通过提高向客户提供的产品和服务的水平, 从而加强客户满意度, 并逐渐增加在各个国家性及全球性市场上的商业活动。

为了达到这些目标, KINTEK 追求、确保并改进:

- 遵守法律, 遵循所提供的产品的技术要求 (通过参加展会和公司培训课程使员工持续得到提升);
- 满足客户提出的明确要求 (通过为国外市场和意大利市场建立一间商务办公室, 在机械工具领域取得高的竞争力和越来越丰富的经验)
- 满足客户未明确提出的暗示性的要求 (仔细考虑收到的订单和发出的报价, 定期、频繁地检查向客户交付货物的质量, 也可以直接拜访客户);
- 以员工的经验提供服务;
- 对索赔及可能存在问题的产品进行管理 (既包括制成品, 也包括内部工业过程);
- 不断地对技术和计算机应用领域进行更新。

这些业务是依据下列原则:

- 内部及外部员工对于质量的参与;
- 找出影响客户满意度的工业过程, 确定对这些过程进行处理和检查的方法;
- 在服务及或产品质量领域进行研发;
- 对过程进行持续的分析和控制, 以找出可改进处。

上述原则是根据下列操作程序制定出来的:

- 规划及实施符合 UNI EN ISO 9001:2008 标准认证质量体系;

在此系统中, 安排决定客户满意度的、具体的过程控制和改进措施。



DET NORSKE VERITAS

QUALITY MANAGEMENT SYSTEM CERTIFICATE

Certificato No. / Certificate No. **CERT-15223-2004-AQ-TRI-SINCERT**

Si attesta che / This certifies that

Il sistema di gestione per la qualità di / the quality management system of

KINTEK S.r.l.

Via Goretta, 88/G – 10072 Caselle Torinese, Frazione Mappano (TO) - Italy

È conforme ai requisiti della norma per i sistemi di gestione per la qualità
Conforms to the quality management systems standard

UNI EN ISO 9001:2008 (ISO 9001:2008)

Questa certificazione è valida per il seguente campo applicativo:
This certificate is valid for the following products or services:

*(Ulteriori chiarimenti riguardanti lo scopo e l'applicabilità dei requisiti della normativa si possono ottenere consultando l'organizzazione certificata)
(Further clarifications regarding the scope and the applicability of the requirements of the standard(s) may be obtained by consulting the certified organization)*

Commercializzazione di portautensili per tornio CNC, mandrini (ISO-HSK-Caletamento), utensili a fissaggio meccanico, utensili con attacco HSK, accessori per macchine utensili sia in versione standard, sia speciali

Marketing of toolholder for CNC lathers Standard and HSK toolholder (shrink fit chucks) turning tools, HSK holder and toolholders, accessories for N/CMachine

Vertrieb von Werkzeughaltern für CNC-Drehmaschinen, ISO-und HSK-Steilgekelaufnahmen, Klemmhaltern, Zubehot für Standard und Sonder – Werkzeugmeschinen

Data Prima Emissione
First Issue Date *
2004-12-10

Luogo e data
Place and date
Agrate Brianza, (MI) 2010-09-24

Settore EA : 29a - 17

Marco Salerno
Lead Auditor

SINCERT
ACCREDITAMENTO ORGANISMI DI CERTIFICAZIONE E ISPEZIONE

SGQ Registrazione N. 003A
SGA Registrazione N. 003D
PRQ Registrazione N. 003B

Membro degli Accordi di Mutuo Riconoscimento EA e IAF
Signatory of EA and IAF Mutual Recognition Agreements

Data di scadenza
Expiry Date
2013-10-08

per l'Organismo di Certificazione
for the Accredited Unit
DET NORSKE VERITAS ITALIA S.R.L.

Vittore Marangon
Management Representative



STANDARD STEILKEGELAUFNAHMEN, ZUBEH R UND KIT
STANDARD TOOLHOLDERS, ACCESSORIES AND KITS
ОПРАВКИ SK(7:24), ЗАПАСНЫЕ ЧАСТИ И ПРИНАДЛЕЖНОСТИ

MANDRINS STANDARD, ACCESSOIRES ET KITS
MANDRINI STANDARD, ACCESSORI E KIT
标准刀柄、附件及组套

PAG.

006-179



HSK STEILKEGELAUFNAHMEN UND ZUBEH R
TOOLHOLDERS AND ACCESSORIES
ОПРАВКИ HSK, ЗАПАСНЫЕ ЧАСТИ
И ПРИНАДЛЕЖНОСТИ
MANDRINS HSK ET ACCESSOIRES
MANDRINI CON ATTACCO HSK E ACCESSORI
HSK刀柄及附件



WERKZEUGHALTER DIN ISO 26623-1
TOOLHOLDERS DIN ISO 26623-1
СТАНКОВ DIN ISO 26623-1

PORTE-OUTILS DIN ISO 26623-1
PORTAUTENSILI DIN ISO 26623-1
刀柄 DIN ISO 26623-1

PAG.

180-275



ANGETRIEBENE WERKZEUGHALTER F R CNC-DREHMASCHINEN NACH DIN 69880
DRIVEN TOOLS FOR CNC LATHES TO DIN 69880
ПРИВОДНЫЕ ТОКАРНЫЕ ГОЛОВКИ ПО DIN 69880 ДЛЯ СТАНКОВ С ЧПУ

PORTE-OUTILS TOURNANTS VDI POUR TOURS CNC SELON DIN 69880
PORTAUTENSILI ROTANTI VDI PER TORNI CNC SECONDO DIN 69880
符合 DIN 69880 标准的 CNC 数控车床驱动工具

PAG.

276-311



WERKZEUGHALTER F R CNC-DREHEMASCHINEN
TOOLHOLDERS FOR CNC LATHES
РЕЗЦЕДЕРЖАТЕЛИ ДЛЯ ТОКАРНЫХ СТАНКОВ

PORTE-OUTILS POUR TOURS CNC
PORTAUTENSILI PER TORNI CNC
数控车床刀柄

PAG.

312-373



SONDER-WERKZEUGHALTER
SPECIAL TOOLHOLDERS
СПЕЦИАЛЬНЫЕ РЕЗЦЕДЕРЖАТЕЛИ

PORTE-OUTILS SPECIAUX
PORTAUTENSILI SPECIALI
特殊刀柄

PAG.

374-425



HSK KLEMMHALTER UND WERKZEUGHALTER
HSK HOLDERS AND TOOLHOLDERS
ДЕРЖАВКИ И РЕЗЦЕДЕРЖАТЕЛИ С ХВОСТОВИКОМ HSK

OUTILS ET PORTE-OUTILS AVEC ATTACHEMENT HSK
UTENSILI E PORTAUTENSILI CON ATTACCO HSK
HSK 柄及刀柄

PAG.

426-465



RAIMAX AUSDREHKOPF
RAIMAX BORING HEAD
РАСТОЧНЫЕ ГОЛОВКИ РЕГУЛИРУЕМЫЕ RAIMAX

RAIMAX T TE
TESTINE RAIMAX
RAIMAX 镗头

PAG.

466-473



EINBAUHALTER
CARTRIDGES
КАРТРИДЖИ

CARTOUCHES
CARTUCCE
刀头

PAG.

474-487



KLEMMHALTER F R AUSSENBEARBEITUNG
UND BOHRSTANGEN F R INNENBEARBEITUNG
EXTERNAL (O.D.) TURNING TOOLS AND INTERNAL (I.D.) BORING BARS
ТОКАРНЫЙ ИНСТРУМЕНТ ДЛЯ ВНЕШНЕЙ И ВНУТРЕННЕЙ ОБРАБОТКИ

PORTE-PLAQUETTES EXTERIEURES, INTERIEURES
PORTA INSERTI PER ESTERNI E BARENI PER INTERNI
外部车刀-内部镗头

PAG.

488-511

KANTER





STANDARD STEILKEGELAUFNAHMEN UND ZUBEHÖR



STANDARD TOOLHOLDERS AND ACCESSORIES



ОПРАВКИ SK (7:24) И ЗАПАСНЫЕ ЧАСТИ



MANDRINS STANDARD ET ACCESSOIRES



MANDRINI STANDARD E ACCESSORI



和元件安装

- **DIN 2080** PAG. 008-027
- **DIN 69871 A-AD/B-AD** PAG. 028-071
- **JIS B 6339
MAS 403/BT A-AD/B-AD** PAG. 072-117
- **ACCESSORIES - ACCESSORI** PAG. 118-174
- **KIT** PAG. 175-179





KAMATEK



DIN 2080



TECHNISCHE DATEN DER STEILKEGELWERKZEUGE
 TAPER SHANKS DATA SHEET
 КОНСТРУКТИВНЫЕ РАЗМЕРЫ

DONNEES TECHNIQUES QUEUE D'OUTILS
 DATI TECNICI CONI D'ATTACCO
 锥柄数据表

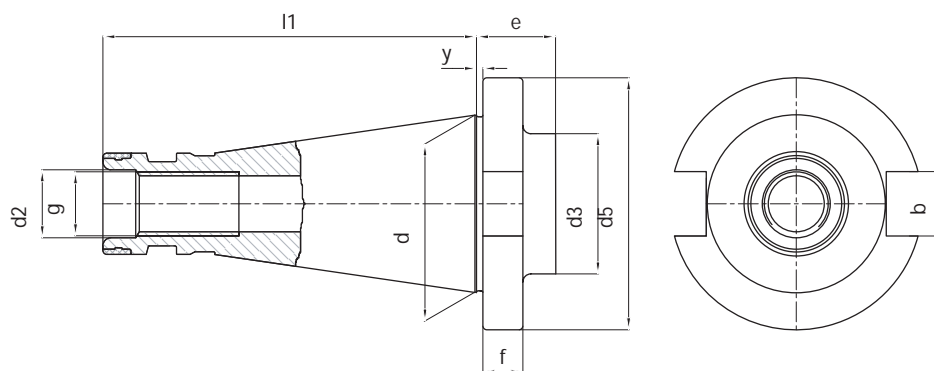

ISO	d	l1	d2	g	y	d5	f	d3	e	b
30	31,75	68,4	13	M12	1,6	50	8	36	18,6	16,1
40	44,45	93,4	17	M16	1,6	63	10	50	22,6	16,1
50	69,85	126,8	26	M24	3,2	97,5	12	78	31,2	25,7



Alle Kintek-Steilkegelaufnahmen werden nach den DIN-Normen angefertigt.

KEGELSCHAFTTOLERANZ

In Klasse AT3 angefertigt.

ISO	L	dA-dB	AT3
30	42	12.250	+0.002
40	59	17.208	+0.003
50	92	26.833	+0.004

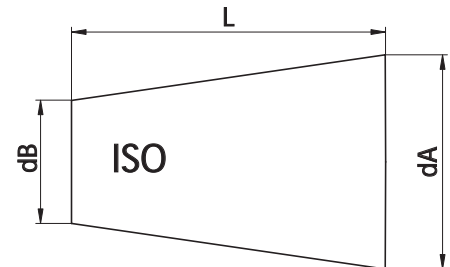

RUNDLAUFGENAUIGKEIT DER SPANNZANGENAUFNAHME

Die DIN 6391- Norm schreibt eine Rundlaufgenauigkeit zwischen Aussenkegel und Innenkegel / Spannzangensitz vom 0,016 vor. Unsere Spannzangenfutter weisen einen Rundlauffehler zwischen ISO-Kegelaufnahme und Spannzangensitz, der zwischen 0,003 und 0,010 mm liegt.

AUFSTECKFRÄSDORNE - RUNDLAUFGENAUIGKEIT

Kintek- Aufsteckfräsdorne entsprechen der DIN 6358- Norm, die einen höchsten Rundlauffehler zwischen ISO 30- und ISO40- Kegel und den Durchmessern 16-22-27-32-40 vom 0,01 vorsieht. Der mögliche höchste Rundlauffehler für ISO 50 ist 0,015 mm.

WELDON AUFSTECKFRÄSDORNE - RUNDLAUFGENAUIGKEIT

Nach der DIN 6359-1-Norm müssen die Weldon- Aufsteckfräsdorne die folgenden Forderungen aufweisen:

Bohrung: Toleranz H5

Rundlaufgenauigkeit: höchster möglicher Rundlauffehler zwischen Kegel und Weldonsitz < 0,01 (für ISO 40)

Die vorgeschriebene Toleranz der Bohrung und eine durchschnittliche Rundlaufgenauigkeit von 0,005 sind verisichert.

KONSTRUKTIONSDATEN

- aus legiertem Einsatzstahl angefertigt
- in der Einsatzhärte tiefe von 0,4-0,5 mm
- gehärtet, angelassen
- Härte HRC58 +-2, Festigkeit 800-1000 N/mm²
- brüniert
- inneres, äußeres Schleifen und am Gewinde der Spannzangemutter



ALL KINTEK TOOLHOLDERS ARE MANUFACTURED ACCORDING TO DIN NORM.

CONE'S TOLERANCE

ACCORDING TO THE CLASS AT3.

ISO	L	dA-dB	AT3
30	42	12.250	+0.002
40	59	17.208	+0.003
50	92	26.833	+0.004

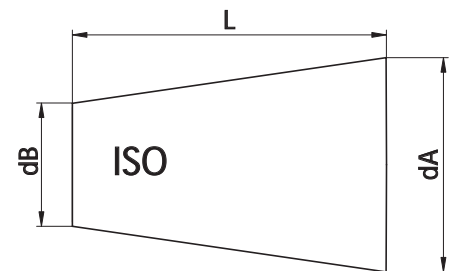

COLLET CHUCK'S RUNOUT ACCURACY

The norm DIN6391 permits a runout error between external cone and internal cone / collet seat of 0.016. Our production has a runout accuracy which is guaranteed to be within 0,003 / 0,010 m at the tool seat.

SHELL END MILL ADAPTOR'S RUNOUT ACCURACY

Our shell end mill adaptors meet the requirements of the norm DIN6358, which prescribes for diameters 16-22-27-32-40 a runout accuracy of: 0, 01 for SK 30/40 0,015 for SK 50.

WELDON END MILL HOLDER'S RUNOUT ACCURACY

According to the norm DIN6359-1 Weldon end mill holders have to meet the following requirements:

Bore: H5 tolerance

Runout accuracy: < 0.01 (for SK 40)

Our end mill adaptors ensure the prescribed holes' tolerance and have a runout accuracy which is normally 0.005

CONSTRUCTIVE FEATURES

- Manufactured with Casehardening Steel.
- Casehardened with depth 0,4 - 0,5 mm
- Hardened-Tempered
- Hardness HRC 58+-2, Strength 800-1000 N/mm2
- Black oxidized
- Internal and external grinding finished.



Все оправки KINTEK произведены согласно стандарту DIN.

ТОЧНОСТЬ КОНУСА

Соответствует классу АТ3.

ISO	L	dA-dB	AT3
30	42	12.250	+0.002
40	59	17.208	+0.003
50	92	26.833	+0.004

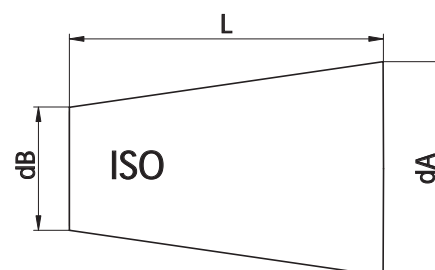

БИЕНИЕ ЦАНГОВЫХ ПАТРОНОВ

В соответствие с нормами DIN 6391, допустимое биение конуса оправки относительно конического отверстия под цангу составляет 0,016 мм. Гарантированная точность биения отверстия под инструмент - 0,003 мм/0,010 м.

БИЕНИЕ ОПРАВОК ДЛЯ НАСАДНЫХ ФРЕЗ

Патроны изготовлены в соответствие с требованиями DIN 6358, согласно которым биение для диаметров 16-22-27-32-40 составляет 0,01 мм для SK 30/40 и 0,015 мм для SK 50.

БИЕНИЕ ПАТРОНОВ С КРЕПЛЕНИЕМ WELDON

Оправки соответствуют следующим требованиям DIN 6359-1:

Точность отверстия: H5

Биение: < 0,01 (для SK 40)

Оправки Kintek изготовлены с гарантированной точностью отверстий и биением 0,005 мм.

КОНСТРУКТИВНЫЕ ОСОБЕННОСТИ

- Изготовлены из стали с последующей цементацией
- Цементация на глубину 0,4 - 0,5 мм
- Оправки подвергнуты закалке и отпуску
- Твердость 58+/-2 HRC, прочность 800-1000 Н/мм²
- Защитно-декоративное покрытие черного цвета
- Шлифованные внутренняя и внешняя поверхности



TOUS LES MANDRINS PORTE-OUTILS KINTEK SONT PRODUITS SUIVANT LES SPÉCIFICATIONS DIN

TOLERANCE DU CONE

EN CLASSE AT3.

ISO	L	dA-dB	AT3
30	42	12.250	+0.002
40	59	17.208	+0.003
50	92	26.833	+0.004

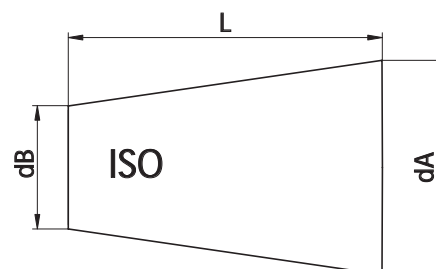

COAXIALITE' PORTE-PINCE

La norme DIN6391 admet une erreur maximum de 0.016 soit pour les porte-pinces DIN6499 soit pour DIN6388. Dans notre production l'écart d'excentricité maximum entre cône ISO et logement de la pince est compris entre: 0,003 et 0,0010 mm.

COAXIALITE' PORTE-FRAISES FIXES ET COMBINES

Les porte-fraises fixes et combinés de notre production suivent la spécification de la norme DIN6358, qui prévoit pour les diamètres 16-22-27-32-40 une concentricité de 0,01 pour ISO 30 et ISO 40, 0,015 pour ISO 50

COAXIALITE' PORTE-FRAISES WELDON

Suivant les spécifications DIN 6359-1 les porte-fraises WELDON doivent suivre les conditions suivantes:

Trou : tolérance H5

Coaxialité: écart maximum toléré entre cône et logement du Weldon <0.01 (pour ISO 40).

Nous assurons la tolérance prévue sur le trou et une coaxialité en moyenne de 0.005.

ELEMENTS DE CONSTRUCTION

- Produits en acier cémenté allié.
- Cémentés avec une profondeur 0,4 - 0,5 mm
- Trempés - Revenus
- Dureté HRC 58 +/- 2 résistance 800-1000 N/ mm²
- Brunis
- Rectification du cône intérieur, extérieur et dans le filetage des écrous qui serrent la pince.



TUTTI I MANDRINI PORTAUTENSILI KINTEK VENGONO PRODOTTI SECONDO LE NORMATIVE DIN

TOLLERANZA DEL CONO

PRODOTTI IN CLASSE AT3.

ISO	L	dA-dB	AT3
30	42	12.250	+0.002
40	59	17.208	+0.003
50	92	26.833	+0.004

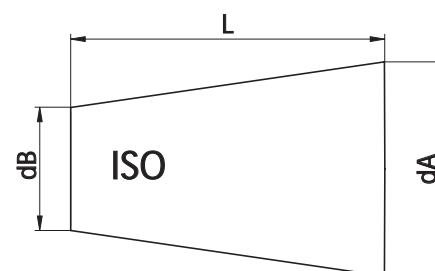

COASSIALITÀ PORTAPINZE

La norma DIN6391 ammette un'errore massimo di 0,016 sia per i portapinze DIN6499 che per DIN6388.

La nostra produzione normalmente presenta uno scostamento massimo di eccentricità tra cono ISO e sede pinza compreso tra i 0,003 e 0,010 mm.

COASSIALITÀ PORTAFRESE FISSI E COMBINATI

I portafrese fissi e combinati di nostra produzione rispondono ai criteri prescritti dalla norma DIN6358, la quale prevede un errore massimo di coassialità tra cono ISO 30 e ISO 40 ed i diametri 16-22-27-32-40, di 0,01.

Mentre per ISO 50 è ammesso un errore massimo di 0,015 mm.

COASSIALITÀ PORTAFRESE WELDON-WHISTLE NOTCH

Rispettando la normativa DIN 6359-1 i portafrese WELDON devono rispondere ai seguenti requisiti:

foro: tolleranza H5

coassialità: scostamento massimo consentito tra cono e sede Weldon <0.01 (per ISO 40)

Garantiamo la tolleranza prescritta sul foro e un valore di coassialità mediamente di 0.005.

DATI COSTRUTTIVI

- Costruiti in acciaio da cementazione legato.
- Cementati con profondità 0,4 - 0,5 mm
- Temprati-rinvenuti
- Durezza HRC 58 +/- 2 resistenza 800-1000 N/ mm²
- Bruniti
- Finitura di rettifica interna, esterna e nelle filettature delle ghiere chiudipinza



所有 KINTEK 刀柄均根据 DIN 标准来制造。

锥体的误差

根据 AT3 级别

ISO	L	dA-dB	AT3
30	42	12.250	+0.002
40	59	17.208	+0.003
50	92	26.833	+0.004

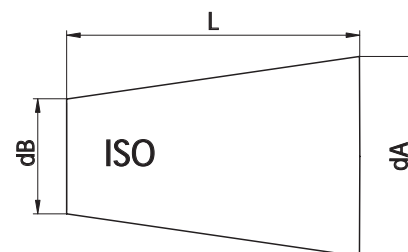

弹簧夹头的径向跳动精度

DIN6391 标准允许在外部锥体与内部锥体/夹头座之间的径向跳动误差为 0.016。我公司的生产保证在工具底座处径向跳动精度为 0,003 / 0,010 米之间。

平面铣接头的径向跳动精度

我公司的平面铣接头满足 DIN6358 标准要求，该标准规定了直径为 16-22-27-32-40 的径向跳动精度，对于 SK 30/40 为 0,01，对于 SK 50 为 0,015。

威尔登式端铣夹具的径向跳动精度

根据 DIN6359-1 标准规定，威尔登式端铣夹具必须要达到下列要求：

孔：H5 误差

径向跳动精度：< 0.01 (对于 SK 40)

我公司的平面铣接头确保可达到规定的孔的误差，通常的径向跳动精度为 0.005。

结构特点

- 用表面硬化钢材制造。
- 硬化深度达 0,4 - 0,5 毫米。
- 经过硬化及回火处理。
- 硬度达 HRC 58+-2，强度达 800-1000 N/平方毫米。
- 黑色氧化。
- 内部及外部表面打磨处理。

ZYLINDERSCHAFTAUFNAHME WELDON
END MILL HOLDERS WELDON
ОПРАВКИ С КРЕПЛЕНИЕМ WELDON

MANDRINS POUR OUTILS TYPE WELDON
MANDRINI PORTAFRESE TIPO WELDON
威尔登式端铣夹具

DIN 1835 B

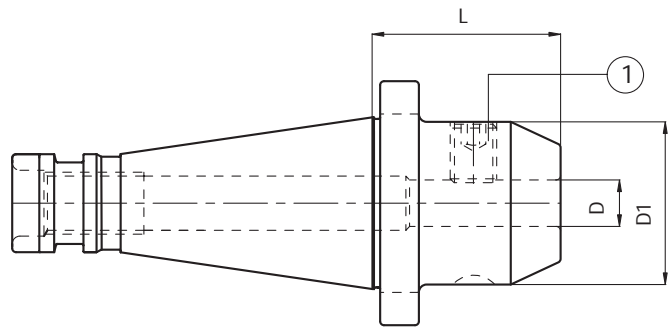

Code N.	Description	ISO	D	L	D1
213-11102	ISO40H50WE06	40	6	50	25
213-11103	ISO40H50WE08	40	8	50	28
213-11104	ISO40H50WE10	40	10	50	35
213-11105	ISO40H50WE12	40	12	50	42
213-11106	ISO40H50WE14	40	14	50	44
213-11107	ISO40H63WE16	40	16	63	48
213-11108	ISO40H63WE18	40	18	63	50
213-11109	ISO40H63WE20	40	20	63	52
213-11110	ISO40H90WE25	40	25	90	65
213-11111	ISO40H90WE32	40	32	90	72
213-11112	ISO50H63WE06	50	6	63	25
213-11113	ISO50H63WE08	50	8	63	28
213-11114	ISO50H63WE10	50	10	63	35
213-11115	ISO50H63WE12	50	12	63	42
213-11116	ISO50H63WE14	50	14	63	44
213-11117	ISO50H63WE16	50	16	63	48
213-11118	ISO50H63WE18	50	18	63	50
213-11119	ISO50H63WE20	50	20	63	52
213-11120	ISO50H80WE25	50	25	80	65
213-11121	ISO50H85WE32	50	32	85	72
213-11122	ISO50H95WE40	50	40	95	78

Ersatzteile • Spare parts • Pièces détachées • Componenti • Запасные части • 零件

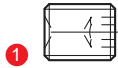
D	Locking screw	Quantity
		
6	811-106001	1
8	811-106002	1
10	811-106004	1
12	811-106005	1
14	811-106005	1
16	811-106006	1
18	811-106006	1
20	811-106007	1
25	811-106008	2
32	811-106009	2
40	811-106009	2

KOMBI - AUFSTECKFRÄSDORNE MANDRINS PORTE- FRAISES A DOUBLE USAGE
 COMBI-SHELL MILL ADAPTORS MANDRINI PORTAFRESE COMBINATI
 КОМБИНИРОВАННЫЕ ОПРАВКИ ДЛЯ НАСАДНЫХ ФРЕЗ 复合式平面铣刀接头

DIN 6358

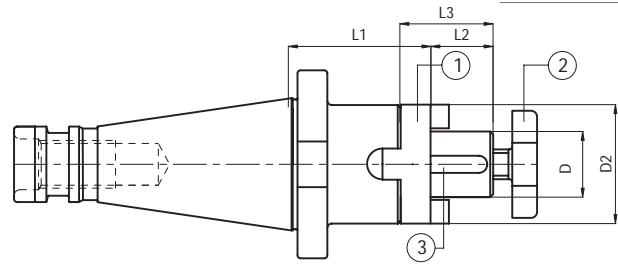

	Code N.	Description	ISO	D	L1	L2	L3	D2
STANDARD	216-11101	ISO40H52D16C	40	16	52	17	27	32
	216-11102	ISO40H52D22C	40	22	52	19	31	40
	216-11103	ISO40H52D27C	40	27	52	21	33	48
	216-11104	ISO40H52D32C	40	32	52	24	38	58
	216-11105	ISO40H52D40C	40	40	52	27	41	70
	216-11106	ISO50H55D16C	50	16	55	17	27	32
	216-11107	ISO50H55D22C	50	22	55	19	31	40
	216-11108	ISO50H55D27C	50	27	55	21	33	48
	216-11109	ISO50H55D32C	50	32	55	24	38	58
	216-11110	ISO50H55D40C	50	40	55	27	41	70

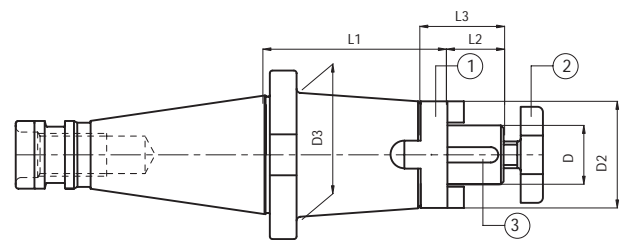

	Code N.	Description	ISO	D	L1	L2	L3	D2	D3
EXTENDED	216-11120	ISO40H100D16C	40	16	100	17	27	32	40
	216-11121	ISO40H100D22C	40	22	100	19	31	40	44
	216-11122	ISO40H100D27C	40	27	100	21	33	48	-
	216-11123	ISO40H100D32C	40	32	100	24	38	58	-
	216-11125	ISO50H100D16C	50	16	100	17	27	32	50
	216-11126	ISO50H100D22C	50	22	100	19	31	40	60
	216-11127	ISO50H100D27C	50	27	100	21	33	48	60
	216-11128	ISO50H100D32C	50	32	100	24	38	58	-
	216-11129	ISO50H100D40C	50	40	100	27	41	70	-

Ersatzteile • Spare parts • Pièces détachées • Componenti • Запасные части • 零件

D	Ring	Cross screw	Key	Wrench
16	814-30001	811-107003	814-201010	816-130002
22	814-30002	811-107004	814-201020	816-130003
27	814-30003	811-107005	814-201030	816-130004
32	814-30004	811-107006	814-201040	816-130005
40	814-30005	811-107007	814-201050	816-130006

AUFSTECKFRÄSDORNE FÜR FRÄSER MIT QUERNUT
 FACE MILL HOLDERS-TENONS DRIVE
 ОПРАВКИ ДЛЯ НАСАДНЫХ ФРЕЗ С УВЕЛИЧЕННЫМ ДИАМЕТРОМ КОРПУСА
 MANDRINS PORTE-FRAISE-ENTRAINEMENT PAR TENONS
 MANDRINI PORTAFRESE A TRASCINAMENTO FISSO
 平面铣刀柄 - 凸棒驱动带有更大的法兰直径

ISO 3937

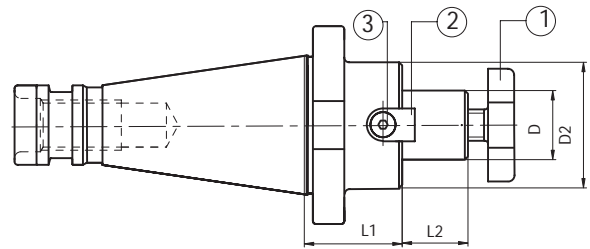

Code N.	Description	ISO	D	L1	L2	D2
216-71105	ISO40H45D16F	40	16	45	17	38
216-71106	ISO40H45D22F	40	22	45	19	48
216-71107	ISO40H45D27F	40	27	45	21	58
216-71108	ISO40H50D32F	40	32	50	24	78
216-71109	ISO40H55D40F	40	40	55	27	88
216-71115	ISO50H45D16F	50	16	45	17	38
216-71116	ISO50H45D22F	50	22	45	19	48
216-71117	ISO50H45D27F	50	27	45	21	58
216-71118	ISO50H50D32F	50	32	50	24	78
216-71119	ISO50H50D40F	50	40	50	27	88

STANDARD



pag. 468-469



pag. 468-469



pag. 468-469

Ersatzteile • Spare parts • Pièces détachées • Componenti • Запасные части • 零件

D/D2	Cross screw	Tenon	Screw	Wrench
16/32	811-107003	814-20214	811-101003	816-130002
16/38	811-107003	814-202280	811-101004	816-130002
22/40	811-107004	814-202150	811-101010	816-130003
22/48	811-107004	814-202250	811-101011	816-130003
27/48	811-107005	814-202160	811-101017	816-130004
27/58	811-107005	814-202270	811-101018	816-130004
32/58	811-107006	814-202170	811-101027	816-130005
32/78	811-107006	814-202630	811-101029	816-130005
40/70	811-107007	814-202180	811-101028	816-130006
40/88	811-107007	814-202710	811-101029	816-130006

AUFSTECKFRÄSDORNE FÜR MESSERKÖPFE
MIT GRÖßEREM BUNDDURCHMESSER
FACE MILL HOLDER FOR FACE MILLING CUTTERS
ОПРАВКИ ДЛЯ ФЛАНЦЕВОГО КРЕПЛЕНИЯ ФРЕЗ

MANDRINS PORTE-FRAISE POUR FRAISES A SURFACER
MANDRINI PORTAFRESE A SPIANARE
CON FLANGIA MAGGIORATA
平面铣刀柄-夹持端铣刀

DIN 6357

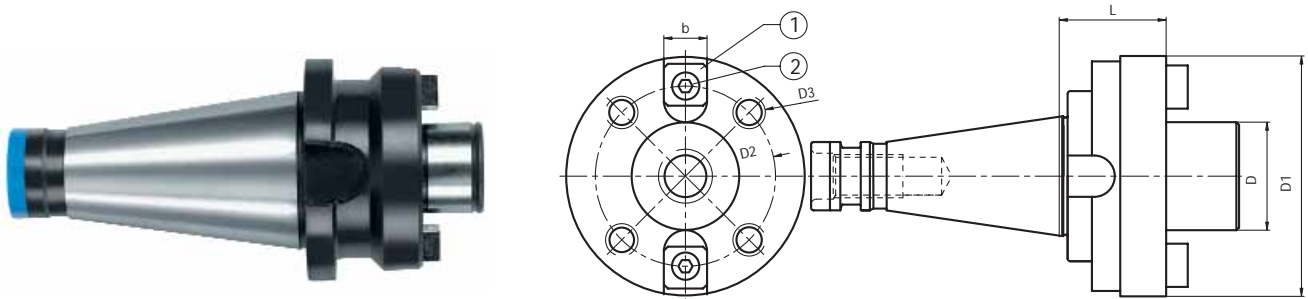

Code N.	Description	ISO	D	L	D1	D2	D3	b
▲ 216-21101	ISO40H46.6D40	40	40	46.6	89	66.7	M12	15.9
▲ 216-21102	ISO50H53.2D40	50	40	53.2	89	66.7	M12	15.9
216-21104	ISO50H70.2D60	50	60	70.2	129	101.6	M16	25.4

▲ INKLUSIVE INNENSCHARUBE • SUPPLIED WITH INTERNAL SCREW • ПОСТАВЛЯЕТСЯ С ВНУТРЕННИМ ВИНТОМ
VIS INTERNE INCLUSE • FORNITO CON VITE CENTRALE INCLUSA • 供货时提供内部螺丝

Ersatzteile • Spare parts • Pièces détachées • Componenti • Запасные части • 零件

D	Tenon	Screw	Cross screw	Wrench
40	814-202080	811-101028	811-107007	816-130006
60	814-202120	811-101063	-	-

ZWISCHENHÜLSEN FÜR MORSEKEGEL MIT AUSTREIBBLAPPEN
MORSE TAPER ADAPTORS FOR DRILLS
ОПРАВКИ ДЛЯ КОНУСА МОРЗЕ С ЛАПКОЙ

DOUILLES POUR CONE MORSE A TENON
MANDRINI PORTAPUNTE ATTACCO CONO MORSE
莫氏锥度钻接头

DIN 228-2 FORM D

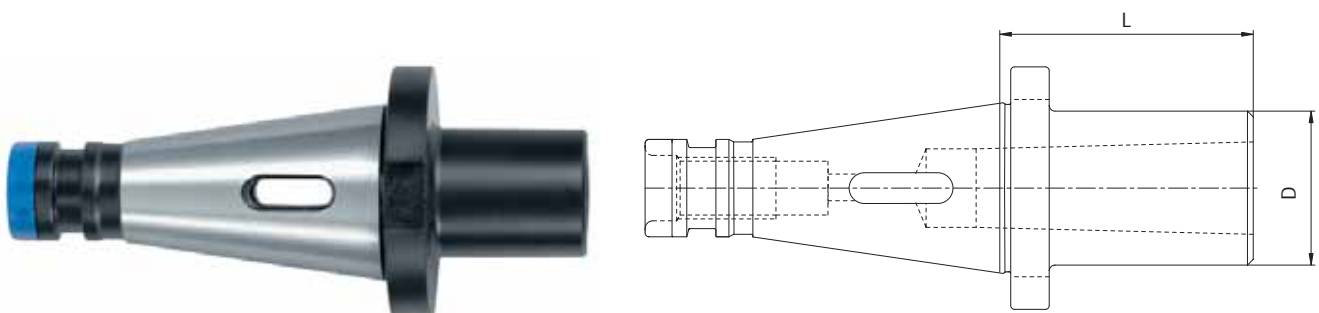

Code N.	Description	ISO	MORSE	D	L
212-41102	ISO40H50CM2P	40	2	32	50
212-41103	ISO40H65CM3P	40	3	40	65
212-41104	ISO40H95CM4P	40	4	48	95
212-41105	ISO50H60CM2P	50	2	32	60
212-41106	ISO50H65CM3P	50	3	40	65
212-41107	ISO50H70CM4P	50	4	48	70

ZWISCHENHÜLSEN FÜR MORESEKegel MIT ANZUGSGEWINDE
 MORSE TAPER ADAPTER WITH THREAD
 ОПРАВКИ ДЛЯ КОНУСА МОРЗЕ С РЕЗЬБОЙ

DOUILLES POUR CONE MORSE AVEC TARAUDAGE
 MANDRINI PORTAFRESE ATTACCO CONO MORSE
 螺纹莫氏锥度接头

DIN 228-2 FORM C

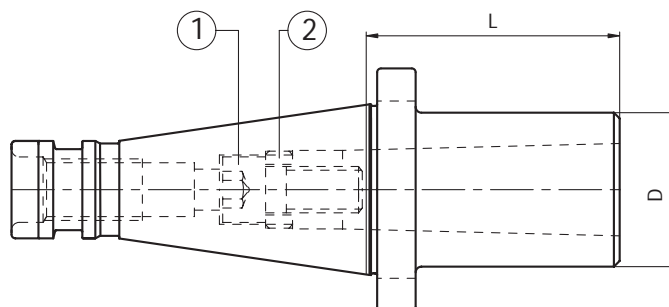

Code N.	Description	ISO	MORSE	D	L
212-21102	ISO40H50CM2F	40	2	32	50
212-21103	ISO40H65CM3F	40	3	40	65
212-21104	ISO40H95CM4F	40	4	48	95
212-21105	ISO50H60CM2F	50	2	32	60
212-21106	ISO50H65CM3F	50	3	40	65
212-21107	ISO50H95CM4F	50	4	48	95
212-21108	ISO50H120CM5F	50	5	63	120

Ersatzteile • Spare parts • Pièces détachées • Componenti • Запасные части • 零件

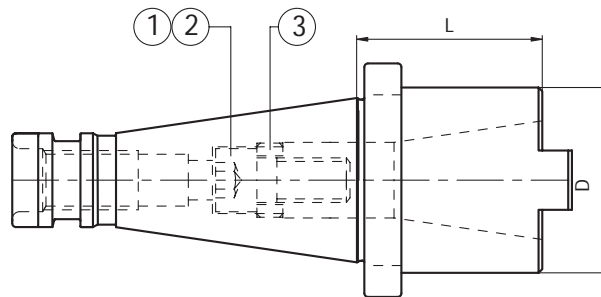

ISO/MORSE	Screw	Ring
40/2	811-111007	811-302031
40/3	811-101065	811-302032
40/4	811-111005	811-302036
50/2	811-101054	811-302032
50/3	811-101065	811-302032
50/4	811-401037	811-302036
50/5	811-101092	811-302034

ZWISCHENHÜLSEN SK X SK DOUILLES INTERMEDIAIRES SA X SA
 ISO TAPER ADAPTORS MANDRINI RIDUZIONE DA DIN2080 A DIN/2080/DIN69871/MAS 403BT
 ПЕРЕХОДНЫЕ ОПРАВКИ SK – SK ISO 锥度接头

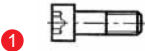

Code N.	Description	ISO	ISO	D	L
212-11102	ISO40H50ISO30/TC30	40	30	50	50
212-11101	ISO50H63ISO40/TC40	50	40	78	63
212-11112	ISO50H100ISO50/TC50	50	50	100	100

Ersatzteile • Spare parts • Pièces détachées • Componenti • Запасные части • 零件

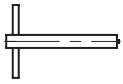
Outside	Inside	Screw (ISO)	Screw (TC)	Ring	Wrench
					
40	30	811-101065	811-101069	811-302032	816-20206002
50	40	811-401037	811-401055	811-302036	816-20207002
50	50	811-401052	811-401135	811-302047	816-202090

Verschlusschraube für DIN69871/MAS BT/DIN2080 werden mitgeliefert
 Supplied with a screw DIN69871/MAS BT/DIN2080
 Livré avec une vis de serrage DIN69871/MAS BT/DIN2080
 In dotazione vite per chiusura DIN69871/MAS BT/DIN2080
 Поставляется с винтом для DIN69871/MAS BT/DIN2080
 供货时提供符合DIN69871/MAS BIT/DIN2080螺丝

SPANNZANGENFUTTER ER TYP MANDRINS A PINCES TYPE ER
 ER COLLET CHUCK MANDRINI PORTAPINZA TIPO ER
 ЦАНГОВЫЕ ПАТРОНЫ ER ER 弹簧夹头

DIN 6499

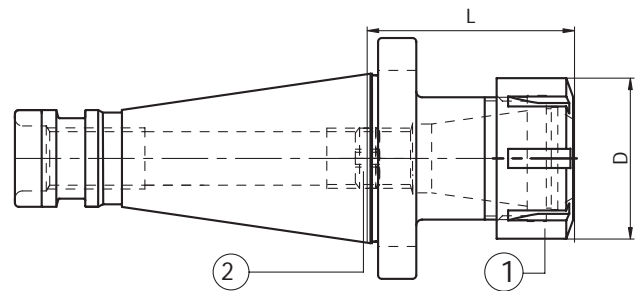

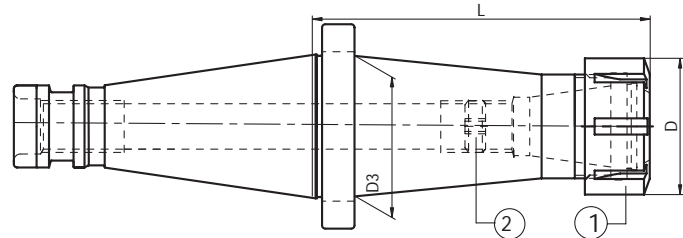

	Code N.	Description	ISO	ER	D	L
STANDARD	214-31105	ISO30H42ER16	30	16	32	42
	214-31106	ISO30H42ER25	30	25	42	42
	214-31107	ISO30H50ER32	30	32	50	50
	214-31152	ISO40H55ER16	40	16	32	55
	214-31101	ISO40H53ER25	40	25	42	53
	214-31102	ISO40H68ER32	40	32	50	68
	214-31114	ISO40H80ER40	40	40	63	80
	214-31137	ISO50H65ER25	50	25	42	65
	214-31103	ISO50H68ER32	50	32	50	68
	214-31104	ISO50H76ER40	50	40	63	76



	Code N.	Description	ISO	ER	D	D3	L
EXTENDED	214-31108	ISO40H110ER25	40	25	42	44	110
	214-31109	ISO40H110ER32	40	32	50	50	110
	214-31138	ISO50H140ER25	50	25	42	44	140
	214-31110	ISO50H140ER32	50	32	50	50	140
	214-31111	ISO50H140ER40	50	40	63	60	140

Ersatzteile • Spare parts • Pièces détachées • Componenti • Запасные части • 零件

ER	Nut	Stop screw	Stop screw
			
16	812-203005	811-303119	-
25	812-203001	811-303121	-
ISO30/25	812-203001	-	811-303001
32	812-203002	811-303118	-
ISO30/32	812-203002	-	811-303001
40	812-203003	811-303122	-

Zubehör
 Accessories
 Accessoires
 Accessori
 Принадлежности
 零件



KRAFTSPANNFUTTER MANDRINS A FORT SERRAGE
 MILLING CHUCK MANDRINI A FORTE SERRAGGIO
 УСИЛЕННЫЕ ОПРАВКИ 铣夹头

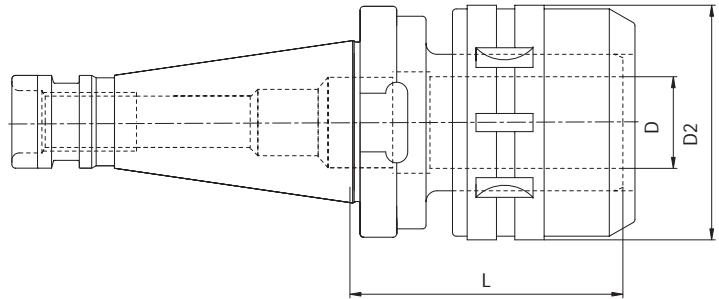

Code N.	Description	ISO	D	D2	L	G6,3 12000 RPM
214-01101	ISO40H83C32	40	32	72	83	•
214-01102	ISO50H85C32	50	32	72	85	•

INKLUSIVE SPANNSCHLÜSSEL • SUPPLIED WITH WRENCH • ПОСТАВЛЯЕТСЯ С КЛЮЧОМ
 CLÉ INCLUSE • FORNITI CON CHIAVE INCLUSA • 供货时提供扳手

Zubehör
 Accessories
 Accessoires
 Accessori
 Принадлежности
 零件

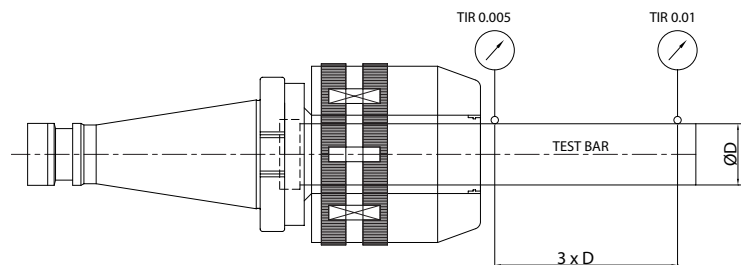

Milling chuck (diameter)	Specification (DIN)	Tolerance (Taper shank)	Run-out (3xD)	Clamping torque
C32	AT3	ISO40 (0~+0,003) ISO50 (0~+0,004)	0~0,01	3430M.m (350 Kgf.m)

KURZBOHRFUTTER UNIVERSAL DRILL CHUCKS
 УНИВЕРСАЛЬНЫЕ СВЕРЛИЛЬНЫЕ ПАТРОНЫ

MANDRINS UNIVERSELS DE PERCAGE
 MANDRINI PORTAPUNTE INTEGRALI
 万能钻头夹头

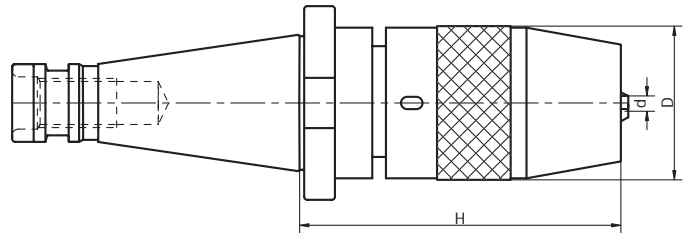

Code N.	Description	ISO	H	D	Clamping capacity	Wrench
252-11100	ISO30H100R1-13	30	100	50	1-13	816-111024
252-11101	ISO40H95R1-13	40	95	50	1-13	816-111024
252-11102	ISO40H105R3-16	40	105	57	3-16	816-111025
252-11103	ISO50H80R1-13	50	80	50	1-13	816-111024
252-11104	ISO50H100R3-16	50	100	57	3-16	816-111025

RUNDLAUFGENAUIGKEIT 0.04 MM
 Zur Erhöhung der Spannkraft werden diese Futter mit Spannschlüssel geliefert.
 BEI LINKS LAUFENDEN BEARBEITUNGEN SIND DIESE FUTTER NICHT ZU BENUTZEN.

RUNOUT ACCURACY 0.04 MM T.I.R.
 Supplied with spanner wrench to allow the application of supplementary gripping torque.
 DO NOT USE IN REVOLUTION IN COUNTER-CLOCKWISE DIRECTION.

БИЕНИЕ 0,04 MM
 Поставляется с ключом для более сильного зажима.
 НЕ ВРАЩАТЬ ПРОТИВ ЧАСОВОЙ СТРЕЛКИ!

PRECISION DE ROTATION 0.04 MM
 Les mandrins sont fournis avec clé de blocage pour augmenter la force de serrage.
 NE PAS UTILISER DANS USINAGE AVEC ROTATION A GAUCHE

PRECISIONE DI ROTAZIONE 0.04 MM
 Per incrementare la forza di serraggio i mandrini sono forniti con chiave di bloccaggio.
 NON DEVONO ESSERE USATI PER LAVORAZIONI CON ROTAZIONE A SINISTRA.

径向跳动精度 0.04 MM T.I.R.
 提供活动扳手，以便施加补充夹紧力。
 不得用于逆时针方向旋转。

KURZBOHRFUTTER FÜR RECHTS-UND LINKSLAUF
 UNIVERSAL DRILL CHUCKS FOR LEFT AND RIGHT ROTATION
 СВЕРЛИЛЬНЫЕ ПАТРОНЫ С ВРАЩЕНИЕМ ПО- И ПРОТИВ ЧАСОВОЙ СТРЕЛКИ ДЛЯ СТАНКОВ С ЧПУ

MANDRINS DE PERCAGE POUR ROTATION GAUCHE-DROITE
 MANDRINI PORTAPUNTE INTEGRALI PER ROTAZIONE DESTRA E SINISTRA
 左右旋转 NC 钻头夹头

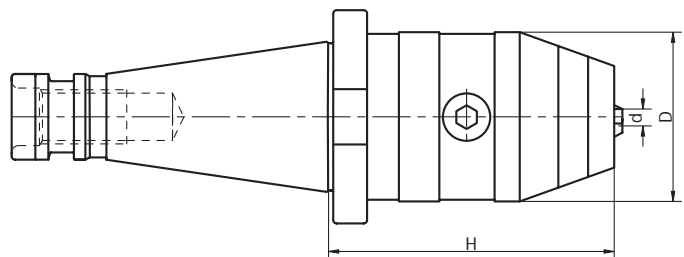

Code N.	Description	ISO	H	D	Clamping capacity	Wrench
252-11105	ISO40H90R1-13X	40	90	50	1-13	816-152001
252-11106	ISO40H100R3-16X	40	100	50	3-16	816-152001
252-11107	ISO50H87R1-13X	50	87	50	1-13	816-152001
252-11108	ISO50H100R3-16X	50	100	50	3-16	816-152001

RUNDLAUFGENAUIGKEIT 0.03 MM
 Sowohl für rechts- als auch links laufende Bearbeitungen geeignet, mit Höchstgeschwindigkeit von 7000 u/min.

RUNOUT ACCURACY 0.03 MM T.I.R.
 Suitable for right and left rotation up to 7000 rpm.

БИЕНИЕ 0,03 MM
 Можно вращать по- и против часовой стрелки со скоростью до 7000 об/мин.

PRECISION DE ROTATION 0.03 MM
 Utilisables pour rotation droite et gauche, avec maximale vitesse 7000 rpm

PRECISIONE DI ROTAZIONE 0.03 MM.
 Adatti per rotazione sia destra che sinistra, con velocità max di 7000 g/min.

径向跳动精度 0.03 MM T.I.R.
 适用于最高转速达 7000 转/分钟的左右旋转

GEWINDESCHNEID-SCHNELLWECHSELFUTTER
MIT LÄNGENAUSGLEICH
TENSION AND COMPRESSION TAPPING HEAD
РЕЗЬБОНАРЕЗНЫЕ ПАТРОНЫ С КОМПЕНСАЦИЕЙ

MANDRINS DE TARAUDAGE A CHANGEMENT
RAPIDE A DOUBLE USAGE
MASCHIATORI A DOPPIA COMPENSAZIONE
张力和压缩丝攻头

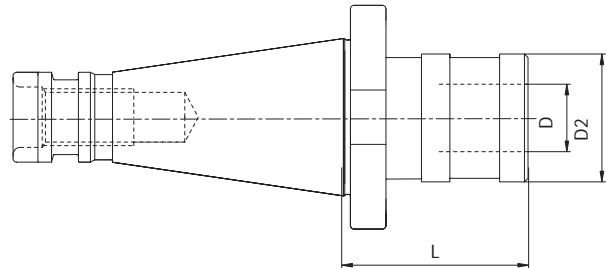

Code N.	Description	ISO	SIZE	Top range	PRESS.	EXT.	D	D2	L
M-1020	ISO40H52GR1DC	40	1	M3-M12	9	9	19	36	52
M-1120	ISO40H77GR2DC	40	2	M6-M20	15	15	31	53	77
M-1130	ISO50H79GR2DC	50	2	M6-M20	15	15	31	53	79
M-1230	ISO50H125GR3DC	50	3	M14-M33	24	24	48	78	125

Zubehör
Accessories
Accessoires
Accessori
Принадлежности
零件



BOHRFUTTERAUFNAHMEN
ARBORS FOR DRILL CHUCKS
ОПРАВКИ ДЛЯ СВЕРЛИЛЬНЫХ ПАТРОНОВ

ARBRES POUR MANDRINS DE PERCAGE
ATTACCO PER MANDRINI PORTAPUNTE
钻夹头刀杆

DIN 238

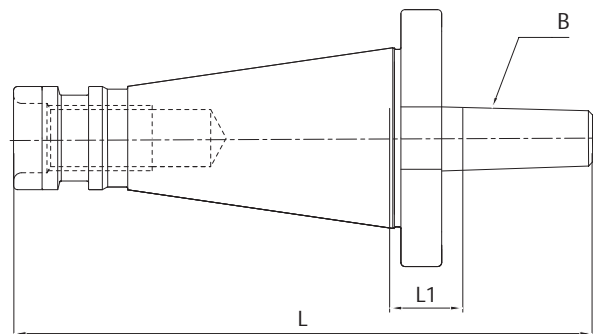

Code N.	Description	ISO	B	L	L1
216-31102	ISO40H17B16	40	16	134.4	17
216-31103	ISO40H17B18	40	18	142.4	17
216-31104	ISO50H20B16	50	16	170.8	20
216-31105	ISO50H20B18	50	18	178.8	20

ROHLINGE MIT WEICHEM SCHAFT
BLANK TOOLHOLDER WITH SOFT SHANK
ЗАГОТОВКИ ДЛЯ ОПРАВОК НЕЗАКАЛЕННЫЕ

BARRES D'ALEPAGE SEMI-FINIES
MANDRINI SEMILAVORATI A STELO TENERO
带软柄的切断刀柄

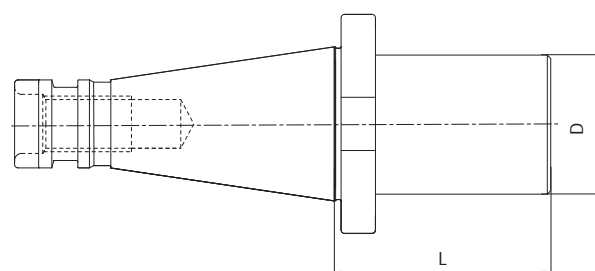

Code N.	Description	ISO	D	L
217-41101	ISO40H160D40.5SM	40	40.5	160
217-41102	ISO40H160D63.5SM	40	63.5	160
217-41103	ISO40H250D63.5SM	40	63.5	250
217-41104	ISO50H160D80SM	50	80	160
217-41106	ISO50H300D80SM	50	80	300

SONDERWERKZEUGHALTER
SPECIAL TOOLS
СПЕЦИАЛЬНЫЕ ИНСТРУМЕНТЫ

PORTE-OUTILS SPÉCIAUX
PRODOTTI SPECIALI
特殊工具



The logo for KAMATEK features the company name in a bold, black, sans-serif font. The letters 'K' and 'K' at the end are stylized with red and black geometric shapes extending from them. The background of the entire page is a light blue gradient with a faint, repeating pattern of interlocking metal rods, similar to a diamond mesh or a structural frame.

KAMATEK

DIN 69871 A-AD/B-AD



TECHNISCHE DATEN DER STEILKEGELWERKZEUGE
TAPER SHANKS DATA SHEET
КОНСТРУКТИВНЫЕ РАЗМЕРЫ

DONNEES TECHNIQUES QUEUE D'OUTILS
DATI TECNICI CONI D'ATTACCO
锥柄数据表

DIN 69871/A

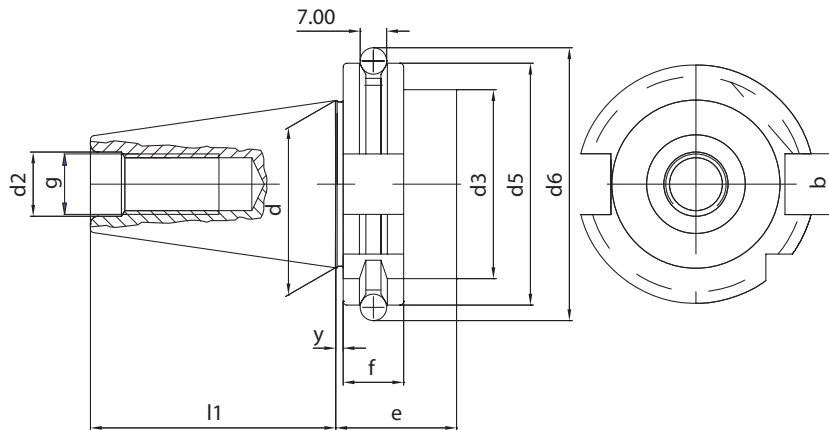

ISO	d	l1	d2	g	y	d5	f	d3	d6	e	b
30	31,75	47,8	13	M12	3,2	50	15,9	45	59,3	35	16,1
40	44,45	68,4	17	M16	3,2	63,55	15,9	50	72,3	35	16,1
50	69,85	101,75	25	M24	3,2	97,5	15,9	80	107,25	35	25,7

TECHNISCHE DATEN DER STEILKEGELWERKZEUGE
TAPER SHANKS DATA SHEET
КОНСТРУКТИВНЫЕ РАЗМЕРЫ

DONNEES TECHNIQUES QUEUE D'OUTILS
DATI TECNICI CONI D'ATTACCO
锥柄数据表

DIN 69871 AD/B

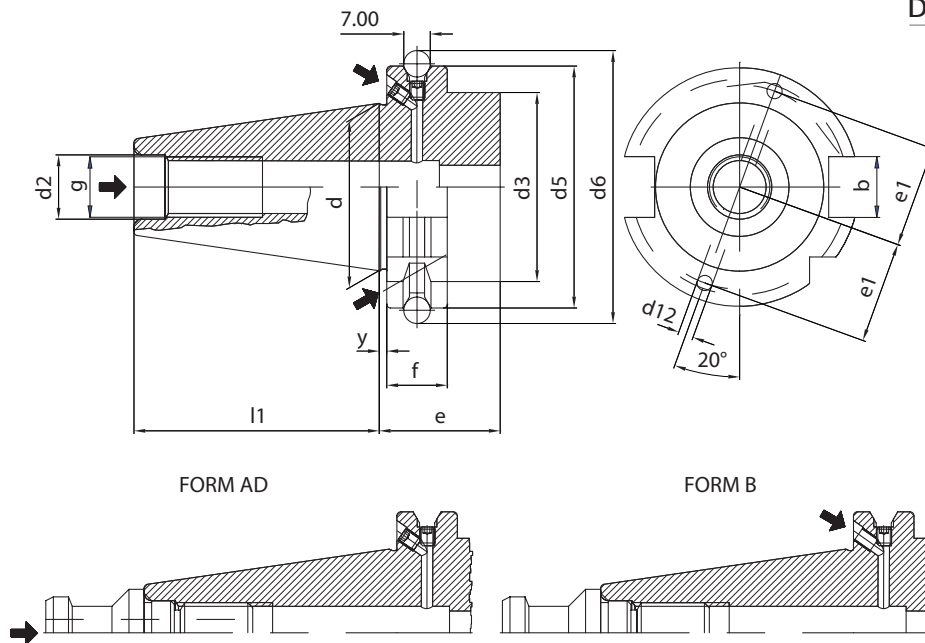

FORM AD

FORM B

ISO	d	l1	d2	g	y	d5	f	d3	d6	e	b	d12	e1
40	44,45	68,4	17	M16	3,2	63,55	15,9	50	72,3	35	16,1	4	27
50	69,85	101,75	26	M24	3,2	97,5	15,9	80	107,25	35	25,7	5	42

Das Kühlmittel geht durch die Löcher am Bund (B) oder, wenn die Löcher mit den Schrauben geschlossen werden, zentral durch Aufnahme (AD).

For coolant through V-flange bores (B) or center of toolholders (AD). For central coolant, the V-flange channels are closed by socket screws.

Для подачи СОЖ через отверстия во фланце (форма В) или через центральное отверстие (форма АD). Для подачи СОЖ через центральное отверстие боковые должны быть закрыты винтами.

Le lubrifiant passe par les trous de la bride (B) ou, si on ferme les trous avec des vis, par le centre du mandrin (AD).

Il lubrificante passa dai fori sulla flangia (B) oppure, chiudendo i fori con le apposite viti, dal centro del mandrino (AD).

冷却剂需通过V型法兰孔 (B) 或刀柄 (AD)。对于中央冷却剂, V型法兰通道是由凹头螺丝拧紧的。



Alle Kintek-Steilkegelaufnahmen werden nach den DIN-Normen angefertigt.

KEGELSCHAFTTOLERANZ

In Klasse AT3 angefertigt.

ISO	L	dA-dB	AT3
30	42	12.250	+0.002
40	59	17.208	+0.003
50	92	26.833	+0.004

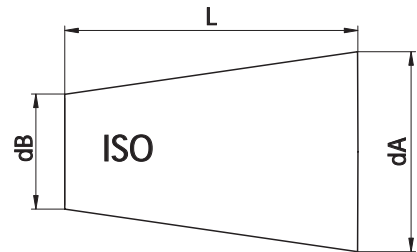

SPANNZANGENAUFNAHME RUNDLAUFGENAUIGKEIT

Die DIN 6391- Norm schreibt eine Rundlaufgenauigkeit zwischen Aussenkegel und Innenkegel / Spannzangensitz vom 0,016 vor. Unsere Spannzangenfutter weisen einen Rundlauffehler zwischen ISO-Kegelaufnahme und Spannzangensitz, der zwischen 0,003 und 0,010 mm liegt.

AUFSTECKFRÄSDORNE - RUNDLAUFGENAUIGKEIT

Kintek- Aufsteckfräsdorne entsprechen der DIN 6358- Norm, die einen höchsten Rundlauffehler zwischen ISO 30- und ISO40- Kegel und den Durchmessern 16-22-27-32-40 vom 0,01 vorsieht. Der mögliche höchste Rundlauffehler für ISO 50 ist 0,015 mm.

WELDON AUFSTECKFRÄSDORNE - RUNDLAUFGENAUIGKEIT

Nach der DIN 6359-1-Norm müssen die Weldon- Aufsteckfräsdorne die folgenden Forderungen aufweisen:
Bohrung: Toleranz H5
Rundlaufgenauigkeit: höchster möglicher Rundlauffehler zwischen Kegel und Weldonsitz < 0,01 (für ISO 40)
Die vorgeschriebene Toleranz der Bohrung und eine durchschnittliche Rundlaufgenauigkeit von 0,005 sind erreicht.

WUCHTUNG

Die meisten Werkzeughalter dieser Gruppe sind in Klasse G6,3 auf 8.000 U/Min -1 vorgewuchtet oder auf 12.000 U/Min -1 gewuchtet.
Neben der Übersichtstabelle der Produkte wird die Wuchtgüte angegeben.

KONSTRUKTIONSDATEN

- aus legiertem Einsatzstahl angefertigt
- in der Einsatzhärte tiefe von 0,4-0,5 mm
- gehärtet, angelassen
- Härte HRC58 +-2, Festigkeit 800-1000 N/mm²
- brüniert
- inneres, äußeres Schleifen und am Gewinde der Spannzangenmutter

WUCHTUNG FÜR HÖHERE DREHZAHLEN

Die Hochgeschwindigkeit- Steilkegelaufnahmen der neuen Linie werden in Klasse G2,5 auf 25.000 U/Min -1 gewuchtet.

KONSTRUKTIONSDATEN

- aus legiertem Einsatzstahl angefertigt
- in der Einsatzhärte tiefe von 0,4-0,5 mm
- gehärtet, angelassen
- Härte HRC 58 +- 2, Festigkeit 800-1000 N/mm²
- brüniert
- inneres, äußeres Schleifen des Kegels
- Schleifen der Vorderseite und am Gewinde der Spannzangenmutter
- 100% durch zertifizierte Meßinstrumente geprüft und mit Wuchtungsprotokoll geliefert



ALL KINTEK TOOLHOLDERS ARE MANUFACTURED ACCORDING TO DIN NORM.

CONE'S TOLERANCE

ACCORDING TO THE CLASS AT3.

ISO	L	dA-dB	AT3
30	42	12.250	+0.002
40	59	17.208	+0.003
50	92	26.833	+0.004

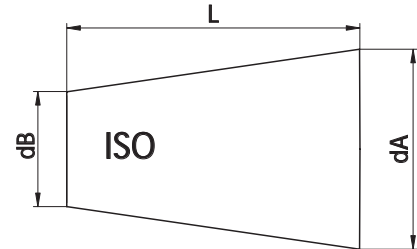

COLLET CHUCK'S RUNOUT ACCURACY

The norm DIN6391 permits a runout error between external cone and internal cone / collet seat of 0.016. Our production has a runout accuracy which is guaranteed to be within 0,003 / 0,010 m at the tool seat.

SHELL END MILL ADAPTOR'S RUNOUT ACCURACY

Our shell end mill adaptors meet the requirements of the norm DIN6358, which prescribes for diameters 16-22-27-32-40 a runout accuracy of: 0, 01 for SK 30/40 0,015 for SK 50.

WELDON END MILL HOLDER'S RUNOUT ACCURACY

According to the norm DIN6359-1 Weldon end mill holders have to meet the following requirements:

Bore: H5 tolerance

Runout accuracy: < 0.01 (for SK 40)

Our end mill adaptors ensure the prescribed holes' tolerance and have a runout accuracy which is normally 0.005

BALANCING

The major part of toolholders of this category can run up to 8000 rpm grade G 6,3 or 12000 rpm. Besides the descriptive and dimensional table of products, you can find the additive balancing grade.

CONSTRUCTIVE FEATURES

- Manufactured with Casehardening Steel.
- Casehardened with depth 0,4 - 0,5 mm
- Hardened-Tempered
- Hardness HRC 58+-2, Strength 800-1000 N/mm²
- Black oxidized
- Internal and external grinding finished.

NEW HIGH-SPEED BALANCING TOOLHOLDERS

The new high-speed toolholders are balanced in the Grade G 2,5 at 25000 rpm.

CONSTRUCTIVE FEATURES FOR HIGH-SPEED TOOLHOLDERS

- Manufactured with casehardening Steel.
- Casehardened with depth 0,4 - 0,5 mm
- Hardened-Tempered
- Hardness HRC 58+-2, Strength 800-1000 N/mm²
- Black oxidized
- Internal and external grinding finish of the cone
- Grinding finish on the front side and on the thread of collet nuts.
- Tested 100% with certified measuring instruments and supplied with balancing certificate



Все оправки KINTEK произведены согласно стандарту DIN.

ТОЧНОСТЬ КОНУСА

Соответствует классу AT3.

ISO	L	dA-dB	AT3
30	42	12.250	+0.002
40	59	17.208	+0.003
50	92	26.833	+0.004

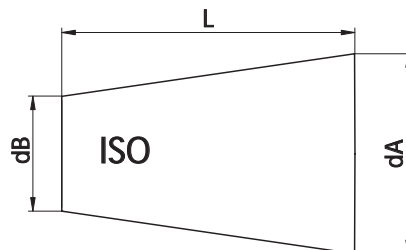

БИЕНИЕ ЦАНГОВЫХ ПАТРОНОВ

В соответствии с нормами DIN6391, допустимое биение конуса оправки относительно конического отверстия под цангу составляет 0,016 мм. Гарантированная точность биения отверстия под инструмент - 0,003 мм/0,010 м.

БИЕНИЕ ОПРАВОК ДЛЯ НАСАДНЫХ ФРЕЗ

Патроны изготовлены в соответствии с требованиями DIN 6358, согласно которым биение для диаметров 16-22-27-32-40 составляет 0,01 мм для SK 30/40 и 0,015 мм для SK 50.

БИЕНИЕ ПАТРОНОВ С КРЕПЛЕНИЕМ WELDON

Оправки соответствуют следующим требованиям DIN 6359-1:

Точность отверстия: H5

Биение: < 0,01 (для SK 40)

Оправки Kintek изготовлены с гарантированной точностью отверстий и биением 0,005 мм.

БАЛАНСИРОВКА

Оправки данной категории предварительно сбалансированы по классу G6,3 при 8000 об/мин или 12000 об/мин.

КОНСТРУКТИВНЫЕ ОСОБЕННОСТИ

- Изготовлены из стали с последующей цементацией
- Цементация на глубину 0,4 - 0,5 мм
- Оправки подвергнуты закалке и отпуску
- Твердость 58+/-2 HRC, прочность 800-1000 Н/мм²
- Защитно-декоративное покрытие черного цвета
- Шлифованные внутренняя и внешняя поверхности

НОВЫЕ ВЫСОКОСКОРОСТНЫЕ СБАЛАНСИРОВАННЫЕ ОПРАВКИ

Новые высокоскоростные оправки сбалансированы до класса G 2,5 при 25000 об/мин.

КОНСТРУКТИВНЫЕ ОСОБЕННОСТИ ВЫСОКОСКОРОСТНЫХ ОПРАВОК

- Изготовлены из стали с последующей цементацией
- Цементация на глубину 0,4 - 0,5 мм
- Оправки подвергнуты закалке и отпуску
- Твердость 58+/-2 HRC, прочность 800-1000 Н/мм²
- Защитно-декоративное покрытие черного цвета
- Шлифованные внутренняя и внешняя поверхности
- Шлифованный торец и резьба под гайку в цанговых патронах
- Каждая оправка испытана и поставляется с сертификатом о балансировке



Tous les mandrins porte-outils KINTEK sont produits suivant les spécifications DIN

TOLERANCE DU CONE

EN CLASSE AT3.

ISO	L	dA-dB	AT3
30	42	12.250	+0.002
40	59	17.208	+0.003
50	92	26.833	+0.004

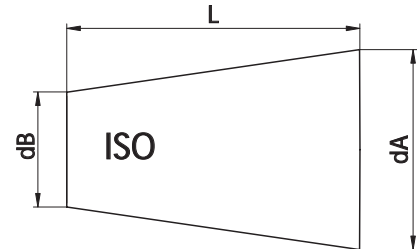

COAXIALITE' PORTE-PINCE

La norme DIN6391 admet une erreur maximum de 0.016 soit pour les porte-pinces DIN6499 soit pour DIN6388. Dans notre production l'écart d'excentricité maximum entre cône ISO et logement de la pince est compris entre: 0,003 et 0,0010 mm.

COAXIALITE' PORTE-FRAISES FIXES ET COMBINES

Les porte-fraises fixes et combinés de notre production suivent la spécification de la norme DIN6358, qui prévoit pour les diamètres 16-22-27-32-40 une concentricité de 0,01 pour ISO 30 et ISO 40, 0,015 pour ISO 50

COAXIALITE' PORTE-FRAISES WELDON

Suivant les spécifications DIN 6359-1 les porte-fraises WELDON doivent suivre les conditions suivantes:

Trou : tolérance H5

Coaxialité: écart maximum toléré entre cône et logement du Weldon <0.01 (pour ISO 40).

Nous assurons la tolérance prévue sur le trou et une coaxialité en moyenne de 0.005.

EQUILIBRAGE

La plupart des porte-outils sont pré-équilibrés en classe G 6,3 8000 Tr/Min -1. ou équilibrés à 12000 Tr/Min-1. A côté du tableau de description et dimensions des produits il y a l'indication de la valeur d'équilibrage additionnel.

ELEMENTS DE CONSTRUCTION

- Produits en acier cémenté allié.
- Cémentés avec une profondeur 0,4 - 0,5 mm
- Trempés - Revenus
- Dureté HRC 58 +/- 2 résistance 800-1000 N/ mm2
- Brunis
- Rectification du cône intérieur, extérieur et dans le filetage des écrous qui serrent la pince.

EQUILIBRAGE MANDRINS POUR HAUTE VITESSE

Les mandrins de la nouvelle ligne à haute vitesse sont équilibrés en classe G 2,5 à 25000 Tr/mn-1.

ELEMENTS DE CONSTRUCTION POUR MANDRINS HAUTE VITESSE

- Produits en acier cémenté allié.
- Cémentés avec une profondeur 0,4 - 0,5 mm
- Trempé - Revenu
- Dureté HRC 58 +/- 2 résistance 800-1000 N/ mm2
- Brunis
- Finition de rectification intérieure, extérieure et du cône
- Rectification du cône intérieur et dans le filetage des écrous qui serrent la pince.
- Contrôlés à 100 % avec des instruments de mesure certifiés et livrés avec un certificat d'équilibrage.



TUTTI I MANDRINI PORTAUTENSILI KINTEK VENGONO PRODOTTI SECONDO LE NORMATIVE DIN

TOLLERANZA DEL CONO

PRODOTTI IN CLASSE AT3.

ISO	L	dA-dB	AT3
30	42	12.250	+0.002
40	59	17.208	+0.003
50	92	26.833	+0.004

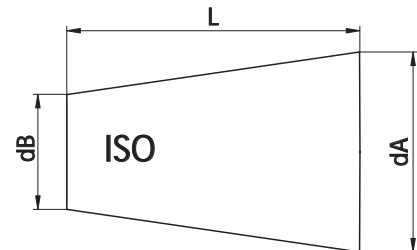

COASSIALITÀ PORTAPINZE

La norma DIN6391 ammette un errore massimo di 0.016 sia per i portapinze DIN6499 che per DIN6388.

La nostra produzione normalmente presenta uno scostamento massimo di eccentricità tra cono ISO e sede pinza compreso tra i 0,003 e 0,010 mm.

COASSIALITÀ PORTAFRESE FISSI E COMBINATI

I portafrese fissi e combinati di nostra produzione rispondono ai criteri prescritti dalla norma DIN6358, la quale prevede un errore massimo di coassialità tra cono ISO 30 e ISO 40 ed i diametri 16-22-27-32-40, di 0,01.

Mentre per ISO 50 è ammesso un errore massimo di 0,015 mm.

COASSIALITÀ PORTAFRESE WELDON - WHISTLE NOTCH

Rispettando la normativa DIN 6359-1 i portafrese WELDON devono rispondere ai seguenti requisiti:

foro: tolleranza H5

coassialità: scostamento massimo consentito tra cono e sede Weldon <0.01 (per ISO 40)

Garantiamo la tolleranza prescritta sul foro e un valore di coassialità mediamente di 0.005.

EQUILIBRATURA

La maggior parte dei portautensili presenti in questa categoria sono prebilanciati in classe G 6,3 8000 rpm min⁻¹. o bilanciati a 12000 giri rpm min⁻¹.

A fianco della tabella descrittiva e dimensionale dei prodotti viene elencato il grado di equilibratura aggiuntiva.

DATI COSTRUTTIVI

- Costruiti in acciaio da cementazione legato.
- Cementati con profondità 0,4 - 0,5 mm
- Temprati-rinvenuti
- Durezza HRC 58 +- 2 resistenza 800-1000 N/ mm2
- Bruniti
- Finitura di rettifica interna, esterna e nelle filettature delle ghiere chiudipinza

EQUILIBRATURA MANDRINI PER ALTE VELOCITÀ

I mandrini presenti nella linea nuova ad alta velocità vengono bilanciati in classe G 2,5 a 25000 rpm min⁻¹.

DATI COSTRUTTIVI MANDRINI PER ALTE VELOCITÀ

- Costruiti in acciaio da cementazione legato.
- Cementati con profondità 0,4 - 0,5 mm
- Temprati-rinvenuti
- Durezza HRC 58 +- 2 resistenza 800-1000 N/ mm2
- Bruniti
- Finitura di rettifica interna, esterna del cono
- Rettifica parte anteriore e nelle filettature delle ghiere chiudipinza
- Collaudati 100% con strumenti di misura certificati e forniti con certificato di bilanciatura.



所有 KINTEK 刀柄均根据 DIN 标准来制造。

锥体的误差

根据 AT3 级别

ISO	L	dA-dB	AT3
30	42	12.250	+0.002
40	59	17.208	+0.003
50	92	26.833	+0.004

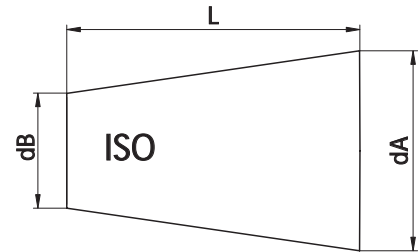

弹簧夹头的径向跳动精度

DIN6391 标准允许在外部锥体与内部锥体/夹头座之间的径向跳动误差为 0.016。我公司的生产保证在工具底座处径向跳动精度为 0,003 / 0,010 米之间。

平面铣接头的径向跳动精度

我公司的平面铣接头满足 DIN6358 标准要求，该标准规定了直径为 16-22-27-32-40 的径向跳动精度，对于 SK 30/40 为 0,01，对于 SK 50 为 0,015。

威尔登式端铣夹具的径向跳动精度

根据 DIN6359-1 标准规定，威尔登式端铣夹具必须要达到下列要求：

孔：H5 误差

径向跳动精度：< 0.01 (对于 SK 40)

我公司的平面铣接头确保可达到规定的孔的误差，通常的径向跳动精度为 0.005。

平衡

这种类型的刀柄的主要部分最高转速可达到 G 6,3 级的 8000 转/分钟或 12000 转/分钟。

结构特点

- 用表面硬化钢材制造。
- 硬化深度达 0,4 - 0,5 毫米。
- 经过硬化及回火处理。
- 硬度达 HRC 58+-2，强度达 800-1000 N/平方毫米。
- 黑色氧化。
- 内部及外部表面打磨处理。

新型高速平衡刀柄

新型高速平衡刀柄在 G 2,5 级，25000 转/分钟达到平衡。

高速刀柄的结构特点

- 用表面硬化钢材制造。
- 硬化深度达 0,4 - 0,5 毫米。
- 经过硬化及回火处理。
- 硬度达 HRC 58+-2，强度达 800-1000 N/平方毫米。
- 黑色氧化。
- 锥体内部及外部表面打磨处理。
- 夹头螺母螺纹正面和上面进行打磨处理。
- 使用经过认证的测量仪器检测，供货时提供平衡检测证书。

ZYLINDERSCHAFTAUFNAHME WELDON
END MILL HOLDERS WELDON
ОПРАВКИ С КРЕПЛЕНИЕМ WELDON

MANDRINS POUR OUTILS TYPE WELDON
MANDRINI PORTAFRESE TIPO WELDON
威尔登式端铣夹具

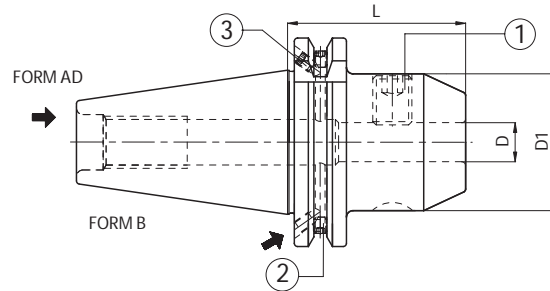

DIN 1835 B



Code N.	Description	ISO	D	L	D1	G2,5 25000 RPM
213-91301	TC40H50WE06 AD+B	40	6	50	25	•
213-91302	TC40H50WE08 AD+B	40	8	50	28	•
213-91303	TC40H50WE10 AD+B	40	10	50	35	•
213-91304	TC40H50WE12 AD+B	40	12	50	42	•
213-91305	TC40H50WE14 AD+B	40	14	50	44	•
213-91306	TC40H63WE16 AD+B	40	16	63	48	•
213-91307	TC40H63WE18 AD+B	40	18	63	50	•
213-91308	TC40H63WE20 AD+B	40	20	63	52	•
213-91309	TC40H100WE25 AD+B	40	25	100	65	•
213-91310	TC40H100WE32 AD+B	40	32	100	72	•
213-91312	TC50H63WE06 AD+B	50	6	63	25	•
213-91313	TC50H63WE08 AD+B	50	8	63	28	•
213-91314	TC50H63WE10 AD+B	50	10	63	35	•
213-91315	TC50H63WE12 AD+B	50	12	63	42	•
213-91316	TC50H63WE14 AD+B	50	14	63	44	•
213-91317	TC50H63WE16 AD+B	50	16	63	48	•
213-91318	TC50H63WE18 AD+B	50	18	63	50	•
213-91319	TC50H63WE20 AD+B	50	20	63	52	•
213-91320	TC50H80WE25 AD+B	50	25	80	65	•
213-91321	TC50H100WE32 AD+B	50	32	100	72	•

High balanced

Ersatzteile • Spare parts • Pièces détachées • Componenti • Запасные части • 零件

Type	Screw	Quantity	Screw	Quantity	D	Locking screw	Quantity
							
ISO 40	811-102002 M4X5	2	811-102002 M4X5	2	6	811-106001	1
ISO 50	811-102001 M4X4	2	811-102010 M5X6	2	8	811-106002	1
					10	811-106004	1
					12,14	811-106005	1
					16,18	811-106006	1
					20	811-106007	1
					25	811-106008	2
					32	811-106009	2

ZYLINDERSCHAFTAUFNAHME WELDON-LANG
 END MILL HOLDERS WELDON-LONG PROJECTION TYPE
 ОПРАВКИ С КРЕПЛЕНИЕМ WELDON. УДЛИНЕННОЕ ИСПОЛНЕНИЕ

MANDRINS POUR OUTILS TYPE WELDON-SERIE LONGUE
 MANDRINI PORTAFRESE TIPO WELDON-SERIE LUNGA
 威尔登式端铣夹具-长形凸点式

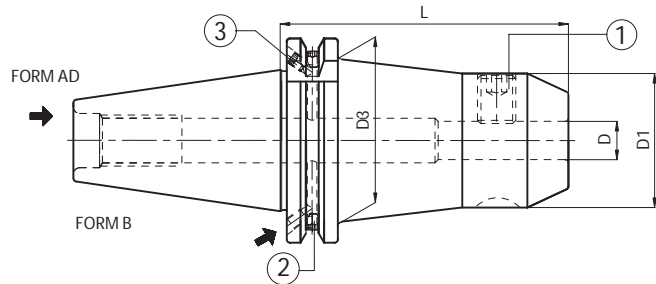

DIN 1835 B



Code N.	Description	ISO	D	L	D1	D3	G2,5 25000 RPM
213-91324	TC40H100WE06 AD+B	40	6	100	25	35	•
213-91325	TC40H100WE08 AD+B	40	8	100	28	38	•
213-91326	TC40H100WE10 AD+B	40	10	100	35	40	•
213-91327	TC40H100WE12 AD+B	40	12	100	42	-	•
213-91328	TC40H100WE14 AD+B	40	14	100	44	-	•
213-91329	TC40H100WE16 AD+B	40	16	100	48	-	•
213-91330	TC40H100WE18 AD+B	40	18	100	50	-	•
213-91331	TC40H100WE20 AD+B	40	20	100	50	-	•
213-91332	TC50H100WE06 AD+B	50	6	100	25	35	•
213-91333	TC50H100WE08 AD+B	50	8	100	28	38	•
213-91334	TC50H100WE10 AD+B	50	10	100	35	42	•
213-91335	TC50H100WE12 AD+B	50	12	100	42	48	•
213-91336	TC50H100WE14 AD+B	50	14	100	44	50	•
213-91337	TC50H100WE16 AD+B	50	16	100	48	54	•
213-91338	TC50H100WE18 AD+B	50	18	100	50	56	•
213-91339	TC50H100WE20 AD+B	50	20	100	52	59	•
213-91340	TC50H100WE25 AD+B	50	25	100	65	-	•

High balanced

Ersatzteile • Spare parts • Pièces détachées • Componenti • Запасные части • 零件

Tape	Screw	Quantity	Screw	Quantity	D	Locking screw	Quantity
							
ISO 40	811-102002 M4X5	2	811-102002 M4X5	2	6	811-106001	1
ISO 50	811-102001 M4X4	2	811-102010 M5X6	2	8	811-106002	1
					10	811-106004	1
					12,14	811-106005	1
					16,18	811-106006	1
					20	811-106007	1
					25	811-106008	2
					32	811-106009	2

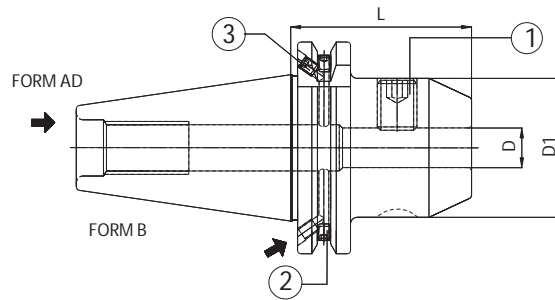

ZYLINDERSCHAFTAUFNAHME WELDON MANDRINS POUR OUTILS TYPE WELDON
 END MILL HOLDERS WELDON MANDRINI PORTAFRESE TIPO WELDON
 ОПРАВКИ С КРЕПЛЕНИЕМ WELDON 威尔登式端铣夹具

DIN 1835 B



Code N.	Description	ISO	D	L	D1	G6,3 12000 RPM
* 263-11201	TC30H45WE06	30	6	45	25	•
* 263-11202	TC30H45WE08	30	8	45	28	•
* 263-11203	TC30H50WE10	30	10	50	35	•
* 263-11204	TC30H50WE12	30	12	50	42	•
* 263-11205	TC30H70WE16	30	16	70	48	•
* 263-11206	TC30H70WE20	30	20	70	52	•
213-11326	TC40H50WE06 AD+B	40	6	50	25	•
213-11327	TC40H50WE08 AD+B	40	8	50	28	•
213-11328	TC40H50WE10 AD+B	40	10	50	35	•
213-11329	TC40H50WE12 AD+B	40	12	50	42	•
213-11330	TC40H50WE14 AD+B	40	14	50	44	•
213-11324	TC40H63WE16 AD+B	40	16	63	48	•
213-11331	TC40H63WE18 AD+B	40	18	63	50	•
213-11325	TC40H63WE20 AD+B	40	20	63	52	•
213-11323	TC40H100WE25 AD+B	40	25	100	65	•
213-11332	TC40H100WE32 AD+B	40	32	100	72	•
213-11393	TC40H115WE40 AD+B	40	40	115	80	•
213-11333	TC50H63WE06 AD+B	50	6	63	25	•
213-11334	TC50H63WE08 AD+B	50	8	63	28	•
213-11335	TC50H63WE10 AD+B	50	10	63	35	•
213-11336	TC50H63WE12 AD+B	50	12	63	42	•
213-11337	TC50H63WE14 AD+B	50	14	63	44	•
213-11338	TC50H63WE16 AD+B	50	16	63	48	•
213-11339	TC50H63WE18 AD+B	50	18	63	50	•
213-11340	TC50H63WE20 AD+B	50	20	63	52	•
213-11341	TC50H80WE25 AD+B	50	25	80	65	•
213-11342	TC50H100WE32 AD+B	50	32	100	72	•
213-11343	TC50H120WE40 AD+B	50	40	120	80	•
263-11343	TC50H120WE50 AD+B	50	50	120	100	•

Ersatzteile • Spare parts • Pièces détachées • Componenti • Запасные части • 零件

Type	Screw	Quantity	Screw	Quantity	D	Locking screw	Quantity
							
ISO 40	811-102002 M4X5	2	811-102002 M4X5	2	6	811-106001	1
ISO 50	811-102001 M4X4	2	811-102010 M5X6	2	8	811-106002	1
					10	811-106004	1
					12,14	811-106005	1
					16,18	811-106006	1
					20	811-106007	1
					25	811-106008	2
					32	811-106009	2
					40	811-106009	2
					50	811-106011	2

* Ausführung Form AD
 * Execution form AD
 * Forme AD
 * Forma AD
 * Исполнение AD
 * 执行形式 AD

ZYLINDERSCHAFTAUFNAHME WELDON-LANG
 END MILL HOLDERS WELDON-LONG PROJECTION TYPE
 ОПРАВКИ С КРЕПЛЕНИЕМ WELDON. УДЛИНЕННОЕ ИСПОЛНЕНИЕ

MANDRINS POUR OUTILS TYPE WELDON-SERIE LONGUE
 MANDRINI PORTAFRESE TIPO WELDON-SERIE LUNGA
 威尔登式端铣夹具-长形凸点式

DIN 1835 B

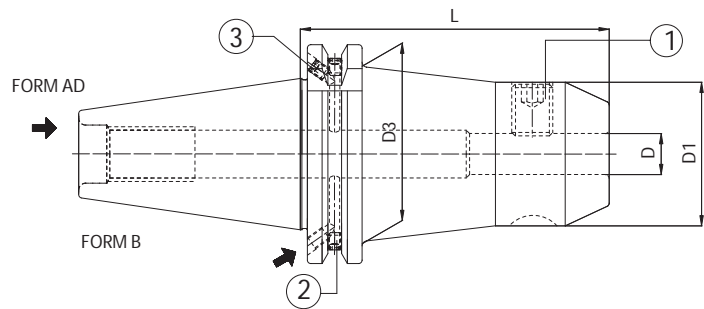

Code N.	Description	ISO	D	L	D1	D3	G6,3 12000 RPM	G6,3 8000 RPM		
H 100	213-11344	TC40H100WE06 AD+B	40	6	100	25	35	•		
	213-11345	TC40H100WE08 AD+B	40	8	100	28	38	•		
	213-11346	TC40H100WE10 AD+B	40	10	100	35	40	•		
	213-11347	TC40H100WE12 AD+B	40	12	100	42	-	•		
	213-11348	TC40H100WE14 AD+B	40	14	100	44	-	•		
	213-11349	TC40H100WE16 AD+B	40	16	100	48	-	•		
	213-11370	TC40H100WE18 AD+B	40	18	100	50	-	•		
	213-11350	TC40H100WE20 AD+B	40	20	100	50	-	•		
	213-11351	TC50H100WE06 AD+B	50	6	100	25	35		•	
	213-11352	TC50H100WE08 AD+B	50	8	100	28	38		•	
	213-11353	TC50H100WE10 AD+B	50	10	100	35	42		•	
	213-11354	TC50H100WE12 AD+B	50	12	100	42	48		•	
	213-11355	TC50H100WE14 AD+B	50	14	100	44	50		•	
	213-11356	TC50H100WE16 AD+B	50	16	100	48	54		•	
	213-11357	TC50H100WE18 AD+B	50	18	100	50	56		•	
	213-11358	TC50H100WE20 AD+B	50	20	100	52	59		•	
	213-11359	TC50H100WE25 AD+B	50	25	100	65	-		•	
	H 160	213-11362	TC40H160WE06 AD+B	40	6	160	25	35	•	
		213-11363	TC40H160WE08 AD+B	40	8	160	28	38	•	
213-11371		TC40H160WE10 AD+B	40	10	160	35	40	•		
213-11372		TC40H160WE12 AD+B	40	12	160	42	-	•		
213-11394		TC40H160WE14 AD+B	40	14	160	44	-	•		
213-11360		TC40H160WE16 AD+B	40	16	160	48	-	•		
213-11395		TC40H160WE18 AD+B	40	18	160	50	-	•		
213-11361		TC40H160WE20 AD+B	40	20	160	50	-	•		
213-11396		TC40H160WE25 AD+B	40	25	160	65	-	•		
213-11397		TC40H160WE32 AD+B	40	32	160	72	-	•		
213-11364		TC50H160WE06 AD+B	50	6	160	25	35		•	
213-11365		TC50H160WE08 AD+B	50	8	160	28	38		•	
213-11366		TC50H160WE10 AD+B	50	10	160	35	42		•	
213-11367		TC50H160WE12 AD+B	50	12	160	42	48		•	
213-11398		TC50H160WE14 AD+B	50	14	160	44	50		•	
213-11368		TC50H160WE16 AD+B	50	16	160	48	54		•	
213-11399		TC50H160WE18 AD+B	50	18	160	50	56		•	
213-11369		TC50H160WE20 AD+B	50	20	160	52	59		•	
263-11301		TC50H160WE25 AD+B	50	25	160	65	70		•	
263-11302	TC50H160WE32 AD+B	50	32	160	72	-		•		

ZYLINDERSCHAFTAUFNAHME WELDON-LANG
 END MILL HOLDERS WELDON-LONG PROJECTION TYPE
 ОПРАВКИ С КРЕПЛЕНИЕМ WELDON. УДЛИНЕННОЕ ИСПОЛНЕНИЕ

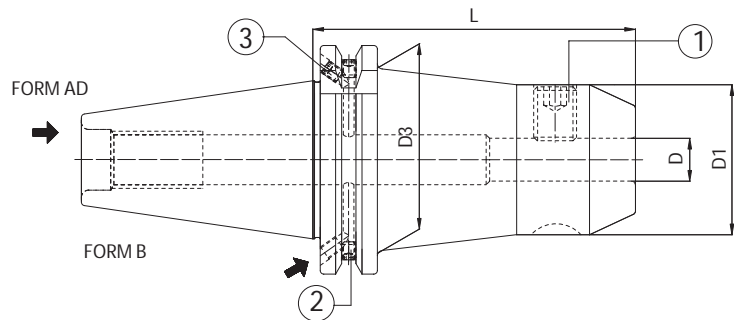

MANDRINS POUR OUTILS TYPE WELDON-SERIE LONGUE
 MANDRINI PORTAFRESE TIPO WELDON-SERIE LUNGA
 威尔登式端铣夹具-长形凸点式

DIN 1835 B



Code N.	Description	ISO	D	L	D1	D3	G6,3 8000 RPM	
H 200	263-11303	TC40H200WE06 AD+B	40	6	200	25	38	•
	263-11304	TC40H200WE08 AD+B	40	8	200	28	41	•
	263-11305	TC40H200WE10 AD+B	40	10	200	35	43	•
	263-11306	TC40H200WE12 AD+B	40	12	200	42	48	•
	263-11307	TC40H200WE14 AD+B	40	14	200	44	48	•
	263-11308	TC40H200WE16 AD+B	40	16	200	48	-	•
	263-11309	TC40H200WE18 AD+B	40	18	200	50	-	•
	263-11310	TC40H200WE20 AD+B	40	20	200	50	-	•
	263-11311	TC40H200WE25 AD+B	40	25	200	65	-	•
	263-11312	TC40H200WE32 AD+B	40	32	200	72	-	•
	263-11313	TC50H200WE06 AD+B	50	6	200	25	38	•
	263-11314	TC50H200WE08 AD+B	50	8	200	28	41	•
	263-11315	TC50H200WE10 AD+B	50	10	200	35	45	•
	263-11316	TC50H200WE12 AD+B	50	12	200	42	51	•
	263-11317	TC50H200WE14 AD+B	50	14	200	44	53	•
	263-11318	TC50H200WE16 AD+B	50	16	200	48	57	•
	263-11319	TC50H200WE18 AD+B	50	18	200	50	59	•
	263-11320	TC50H200WE20 AD+B	50	20	200	52	61	•
	263-11321	TC50H200WE25 AD+B	50	25	200	65	72	•
	263-11381	TC50H200WE32 AD+B	50	32	200	72	-	•

Ersatzteile • Spare parts • Pièces détachées • Componenti • Запасные части • 零件

Type	Screw	Quantity	Screw	Quantity	D	Locking screw	Quantity
							
ISO 40	811-102002 M4X5	2	811-102002 M4X5	2	6	811-106001	1
ISO 50	811-102001 M4X4	2	811-102010 M5X6	2	8	811-106002	1
					10	811-106004	1
					12,14	811-106005	1
					16,18	811-106006	1
					20	811-106007	1
					25	811-106008	2
					32	811-106009	2

KURZE ZYLINDERSCHAFTAUFNAHME WELDON
SHORT END MILL WELDON HOLDERS
ОПРАВКИ С КРЕПЛЕНИЕМ WELDON. КОРОТКОЕ ИСПОЛНЕНИЕ

MANDRINS COURTS PORTE-FRAISE TYPE WELDON
MANDRINI CORTI PORTAFRESE TIPO WELDON
威尔登式短端铣刀夹具

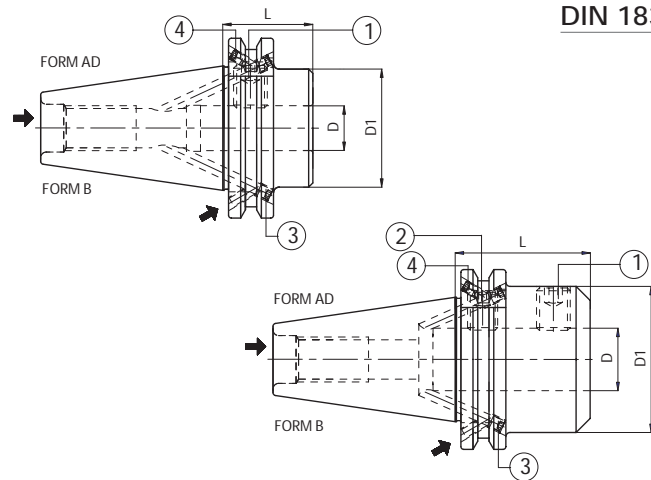

DIN 1835 B

Code N.	Description	ISO	D	L	D1	G6,3 12000 RPM
263-11322	TC40H35WE16 AD+B	40	16	35	44	•
263-11323	TC40H35WE20 AD+B	40	20	35	44	•
263-11324	TC40H35WE25 AD+B	40	25	35	44	•
263-11325	TC40H60WE25 AD+B	40	25	60	49	•
263-11326	TC40H70WE32 AD+B	40	32	70	72	•
263-11327	TC50H35WE16 AD+B	50	16	35	70	•
263-11328	TC50H35WE20 AD+B	50	20	35	70	•
263-11329	TC50H35WE25 AD+B	50	25	35	70	•
263-11330	TC50H35WE32 AD+B	50	32	35	80	•

Extrakurze und feste Ausführung

Extra short and Rigid Version



Экстракороткое и жесткое исполнение



Extra courts et version rigide

Extra corti e versione rigida

超短及坚固型

Ersatzteile • Spare parts • Pièces détachées • Componenti • Запасные части • 零件

Type	Screw	Quantity	Screw	Quantity
				
ISO40	811-102002 M4X5	2	811-102002 M4X5	2
ISO50	811-102001 M4X4	2	811-102010 M5X6	2

Code N.	Locking screw	Quantity	Locking screw	Quantity
				
263-11322	811-106006	1	-	-
263-11323	811-106007	1	-	-
263-11324	811-106014	1	-	-
263-11325	811-106014	2	-	-
263-11326	811-106009	1	811-106026	1
263-11327	811-106006	1	-	-
263-11328	811-106007	1	-	-
263-11329	811-106008	1	-	-
263-11330	811-106009	1	-	-

ZYLINDERSCHAFTAUFNAHME WELDON MIT SPRITZDÜSEN
 END MILL HOLDERS WELDON
 WITH COOLANT NOOSE FRONT FACE
 ОПРАВКИ С КРЕПЛЕНИЕМ
 WELDON И ОТВЕРСТИЯМИ ДЛЯ СОЖ НА ТОРЦЕ

MANDRINS POUR OUTILS TYPE WELDON
 AVEC BUSE D'ARROSAGE
 MANDRINI PORTAFRESE TIPO WELDON
 CON SFERE DI LUBRIFICAZIONE
 威尔登式端铣夹具，配备出水结构

DIN 1835 B

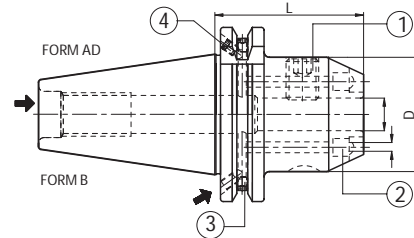
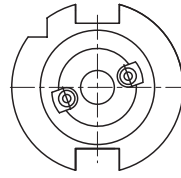

Code N.	Description	ISO	D	L	D1	G6,3 8000 RPM
213-11383	TC40H50WE06-CNFF AD+B	40	6	50	25	•
213-11384	TC40H50WE08-CNFF AD+B	40	8	50	28	•
213-11385	TC40H50WE10-CNFF AD+B	40	10	50	35	•
213-11386	TC40H50WE12-CNFF AD+B	40	12	50	42	•
213-11387	TC40H50WE14-CNFF AD+B	40	14	50	44	•
213-11388	TC40H63WE16-CNFF AD+B	40	16	63	48	•
213-11389	TC40H63WE18-CNFF AD+B	40	18	63	50	•
213-11390	TC40H63WE20-CNFF AD+B	40	20	63	52	•
213-11391	TC40H100WE25-CNFF AD+B	40	25	100	65	•
213-11392	TC40H100WE32-CNFF AD+B	40	32	100	72	•
263-11331	TC40H115WE40-CNFF AD+B	40	40	115	80	•
263-11332	TC50H63WE06-CNFF AD+B	50	6	63	25	•
263-11333	TC50H63WE08-CNFF AD+B	50	8	63	28	•
263-11334	TC50H63WE10-CNFF AD+B	50	10	63	35	•
263-11335	TC50H63WE12-CNFF AD+B	50	12	63	42	•
263-11336	TC50H63WE14-CNFF AD+B	50	14	63	44	•
263-11337	TC50H63WE16-CNFF AD+B	50	16	63	48	•
263-11338	TC50H63WE18-CNFF AD+B	50	18	63	50	•
263-11339	TC50H63WE20-CNFF AD+B	50	20	63	52	•
263-11340	TC50H80WE25-CNFF AD+B	50	25	80	65	•
263-11341	TC50H100WE32-CNFF AD+B	50	32	100	72	•
263-11342	TC50H120WE40-CNFF AD+B	50	40	120	80	•

Ersatzteile • Spare parts • Pièces détachées • Componenti • Запасные части • 零件

Ausführung mit Kühlmittelzufuhr zentral und an dem Bund.

Durch die seitlichen Bohrungen und die Kühlmitteldüsen ermöglicht dieses System das Kühlmittel direkt an den Kontaktpunkt des Werkzeuges zu leiten. Außerdem erfolgt Zentral-Kühlmittelzufuhr, wenn zwei Schrauben die Bohrungen verschliessen.

With central and lateral cooling possibility.

This type of system, thanks to two lateral holes, permits to direct the cooling jet trough the two balls to the connection point of the tool.

Besides, with the application of two screws on the balls, you can have the lubrication trough the centre.

Avec possibilité d'arrosage soit central, soit latéral.

Ce système, avec les trous latéraux, permet, avec les deux billes d'arrosage de diriger le liquide sur le point de contact de l'outil. De plus, il est possible d'avoir l'arrosage au centre en bouchant avec des vis les trous des billes.



Con possibilità di refrigerazione sia centrale che laterale.

Questo tipo di sistema grazie ai due fori laterali, permette, mediante le due sfere di dirigere il getto del refrigerante nel punto di contatto dell'utensile. Inoltre, con l'applicazione di due grani sulle sfere si ottiene la lubrificazione attraverso il centro.

Возможность центрального и бокового охлаждения. Благодаря двум боковым отверстиям, эта система позволяет направлять СОЖ к месту крепления режущего инструмента. Если закрепить два винта в отверстиях фланца, СОЖ подаётся через центр.

具备中央及侧面冷却能力

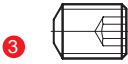
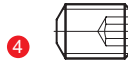
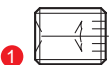
这种类型的系统，由于具备两个侧孔，它可将冷却喷嘴通过两个球头导向工具的连接点。另外，在球头上使用两个螺丝，可使润滑剂通过中心。

Type	Screw	Quantity	Screw	Quantity
				
ISO40	811-102002 M4X5	2	811-102002 M4X5	2
ISO50	811-102001 M4X4	2	811-102010 M5X6	2
D	Locking screw	Quantity	Coolant noose	M
				
6	811-106001	1	PWZ1005D6x4.5	D2.5
8	811-106002	1	PWZ1005D6x4.5	D2.5
10	811-106004	1	PWZ1005D6x4.5	D2.5
12,14	811-106005	1	PWZ1005D6x4.5	D2.5
16,18	811-106006	1	PWZ1008D10x7	M4
20	811-106007	1	PWZ1008D10x7	M4
25	811-106008	2	PWZ1012D12x8	M5
32	811-106009	2	PWZ1012D12x8	M5
40	811-106009	2	PWZ1012D12x8	M5

ZYLINDERSCHAFTAUFNAHME WHISTLE NOTCH
 END MILL HOLDERS WHISTLE NOTCH
 ОПРАВКИ С КРЕПЛЕНИЕМ WHISTLE NOTCH

MANDRINS POUR OUTILS TYPE WHISTLE NOTCH
 MANDRINI PORTAFRESE TIPO WHISTLE NOTCH
 侧固式铣刀柄

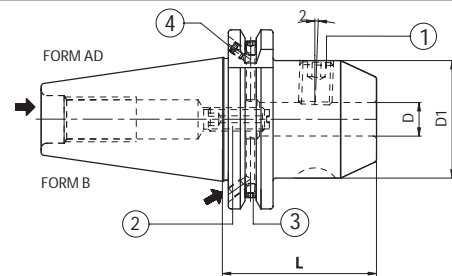

DIN 1835 E

Code N.	Description	ISO	D	L	D1	G6,3 12000 RPM
213-31317	TC40H50WN06 AD+B	40	6	50	25	•
213-31318	TC40H50WN08 AD+B	40	8	50	28	•
213-31319	TC40H50WN10 AD+B	40	10	50	35	•
213-31320	TC40H50WN12 AD+B	40	12	50	42	•
213-31321	TC40H50WN14 AD+B	40	14	50	44	•
213-31322	TC40H63WN16 AD+B	40	16	63	48	•
213-31323	TC40H63WN18 AD+B	40	18	63	50	•
213-31324	TC40H63WN20 AD+B	40	20	63	52	•
213-31325	TC40H100WN25 AD+B	40	25	100	65	•
213-31326	TC40H100WN32 AD+B	40	32	100	72	•
213-31327	TC40H115WN40 AD+B	40	40	115	80	•
213-31328	TC50H63WN06 AD+B	50	6	63	25	•
213-31329	TC50H63WN08 AD+B	50	8	63	28	•
213-31330	TC50H63WN10 AD+B	50	10	63	35	•
213-31331	TC50H63WN12 AD+B	50	12	63	42	•
213-31332	TC50H63WN14 AD+B	50	14	63	44	•
213-31333	TC50H63WN16 AD+B	50	16	63	48	•
213-31334	TC50H63WN18 AD+B	50	18	63	50	•
213-31335	TC50H63WN20 AD+B	50	20	63	52	•
213-31336	TC50H80WN25 AD+B	50	25	80	65	•
213-31337	TC50H100WN32 AD+B	50	32	100	72	•
213-31338	TC50H120WN40 AD+B	50	40	120	80	•

Ersatzteile • Spare parts • Pièces détachées • Componenti • Запасные части • 零件

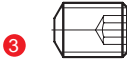
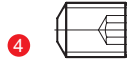
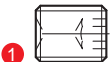
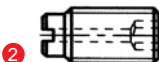
Type	Screw	Quantity	Screw	Quantity
				
ISO40	811-102002 M4X5	2	811-102002 M4X5	2
ISO50	811-102001 M4X4	2	811-102010 M5X6	2
D	Locking screw	Quantity	Stop screw	M
				
6	811-106001	1	811-303043	1
8	811-106002	1	811-303081	1
10	811-106004	1	811-303082	1
12,14	811-106005	1	811-303083	1
16,18	811-106006	1	811-303084	1
20	811-106007	1	811-303084	1
ISO 40/25	811-106008	2	811-303098	1
ISO 50/25	811-106008	2	811-303085	1
ISO 40/32	811-106009	2	811-303098	1
ISO 50/32	811-106009	2	811-303085	1
ISO 40/40	811-106009	2	811-303098	1
ISO 50/40	811-106009	2	811-303085	1

KOMBI - AUFSTECKFRÄSDORNE
COMBI-SHELL MILL ADAPTORS
КОМБИНИРОВАННЫЕ ОПРАВКИ ДЛЯ НАСАДНЫХ ФРЕЗ

MANDRINS PORTE- FRAISES A DOUBLE USAGE
MANDRINI PORTAFRESE COMBINATI
复合式平面铣刀接头

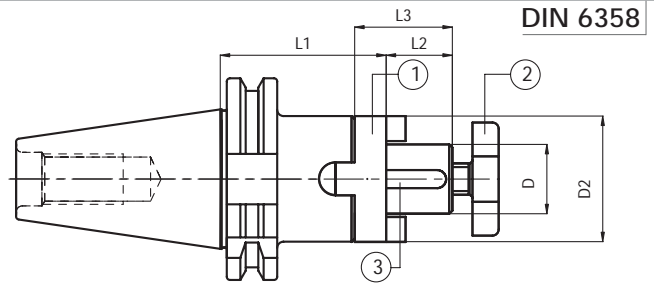

DIN 6358

	Code N.	Description	ISO	D	L1	L2	L3	D2	G6,3 8000 RPM
STANDARD	216-11201	TC40H55D16C	40	16	55	17	27	32	•
	216-11202	TC40H55D22C	40	22	55	19	31	40	•
	216-11203	TC40H55D27C	40	27	55	21	33	48	•
	216-11204	TC40H60D32C	40	32	60	24	38	58	•
	216-11205	TC40H60D40C	40	40	60	27	41	70	•
	216-11206	TC50H55D16C	50	16	55	17	27	32	•
	216-11207	TC50H55D22C	50	22	55	19	31	40	•
	216-11208	TC50H55D27C	50	27	55	21	33	48	•
	216-11209	TC50H55D32C	50	32	55	24	38	58	•
	216-11210	TC50H55D40C	50	40	55	27	41	70	•
	216-11211	TC50H70D50C	50	50	70	30	46	90	•

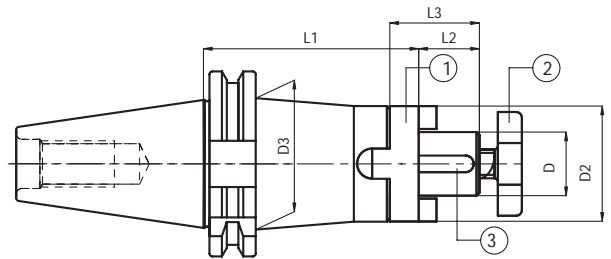

	Code N.	Description	ISO	D	L1	L2	L3	D2	D3	G6,3 8000 RPM
H100	216-11213	TC40H100D16C	40	16	100	17	27	32	44	•
	216-11214	TC40H100D22C	40	22	100	19	31	40	-	•
	216-11215	TC40H100D27C	40	27	100	21	33	48	-	•
	216-11216	TC40H100D32C	40	32	100	24	38	58	-	•
	216-11217	TC40H100D40C	40	40	100	27	41	70	-	•
	216-11218	TC50H100D16C	50	16	100	17	27	32	50	•
	216-11219	TC50H100D22C	50	22	100	19	31	40	60	•
	216-11220	TC50H100D27C	50	27	100	21	33	48	60	•
	216-11221	TC50H100D32C	50	32	100	24	38	58	-	•
	216-11222	TC50H100D40C	50	40	100	27	41	70	-	•

Ersatzteile • Spare parts • Pièces détachées • Componenti • Запасные части • 零件

D	Ring	Cross screw	Key	Wrench
16	814-30001	811-107003	814-201010	816-130002
22	814-30002	811-107004	814-201020	816-130003
27	814-30003	811-107005	814-201030	816-130004
32	814-30004	811-107006	814-201040	816-130005
40	814-30005	811-107007	814-201050	816-130006
50	814-30006	811-107009	814-201060	816-130007

AUFSTECKFRÄSDORNE FÜR FRÄSER
MIT QUERNUT MIT GRÖßEREM BUND
FACE MILL HOLDERS-TENONS DRIVE
WITH BIGGER FLANGE DIAMETER
ОПРАВКИ ДЛЯ НАСАДНЫХ ФРЕЗ С УВЕЛИЧЕННЫМ
ДИАМЕТРОМ КОРПУСА

MANDRINS PORTE-FRAISE-ENTRAINEMENT
PAR TENONS BRIDE AJOUTEE
MANDRINI PORTAFRESE A TRASCINAMENTO FISSO
CON FLANGIA MAGGIORATA
平面铣刀柄 - 凸榫驱动带有更大的法兰直径

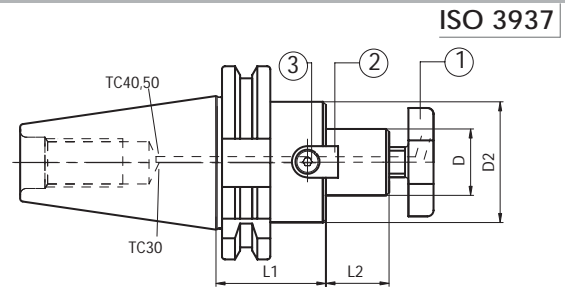

Code N.	Description	ISO	D	L1	L2	D2	G6,3 ⁸⁰⁰⁰ RPM
216-71204	TC40H45D16F	40	16	45	17	38	•
216-71205	TC40H45D22F	40	22	45	19	48	•
216-71206	TC40H50D27F	40	27	50	21	58	•
216-71207	TC40H55D32F	40	32	55	24	78	•
▲ 216-71208	TC40H55D40F	40	40	55	27	88	•
216-71214	TC50H45D16F	50	16	45	17	38	•
216-71215	TC50H45D22F	50	22	45	19	48	•
216-71216	TC50H45D27F	50	27	45	21	58	•
216-71217	TC50H50D32F	50	32	50	24	78	•
▲ 216-71218	TC50H55D40F	50	40	55	27	88	•

- ▲ Zur gebohrten Ausführung, sehen Sie bitte Seite 49
- ▲ For drilled version, please see on page 49
- ▲ Pour le modèle percé voir à la page 49
- ▲ Per versione forata vedi pag 49
- ▲ Оправки для фланцевого крепления фрез на стр. 49



Ersatzteile • Spare parts • Pièces détachées • Componenti • Запасные части • 零件

D	Cross screw	Cross screw on enquiry	Tenon	Screw	Wrench
16	811-107003	811-107013	814-202280	811-101004	816-130002
22	811-107004	811-107014	814-202250	811-101011	816-130003
27	811-107005	811-107015	814-202270	811-101018	816-130004
32	811-107006	811-107016	814-202630	811-101029	816-130005
40	811-107007	811-107017	814-202710	811-101029	816-130006

AUFSTECKFRÄSDORNE FÜR FRÄSER
MIT QUERNUT-LANGE AUSFÜHRUNG
FACE MILL HOLDERS-TENONS DRIVE-LONG PROJECTION TYPE
ОПРАВКИ ДЛЯ НАСАДНЫХ ФРЕЗ. УДЛИНЕННОЕ ИСПОЛНЕНИЕ

MANDRINS PORTE-FRAISE-ENTRAÎNEMENT
PAR TENONS-SERIE LONGUE
MANDRINI PORTAFRESE A TRASCINAMENTO FISSO-SERIE LUNGA
平面铣刀柄 - 凸榫驱动 - 长形凸点式

ISO 3937

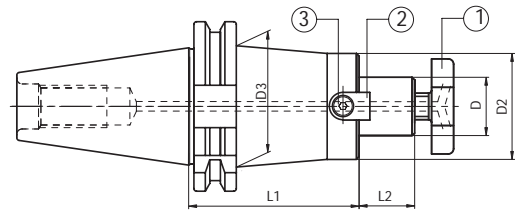

	Code N.	Description	ISO	D	L1	L2	D2	D3		G6,3 8000 RPM
H 100	216-71255	TC40H100D16F	40	16	100	17	39	-	-	•
	216-71259	TC40H100D22F	40	22	100	19	46	48	A	•
	266-71273	TC40H100D27F	40	27	100	21	55	-	C	•
	266-71274	TC40H100D32F	40	32	100	24	66	-	-	•
	266-71275	TC40H100D40F	40	40	100	27	70	-	-	•
	266-71233	TC50H100D16F	50	16	100	17	38	-	-	•
	216-71267	TC50H100D22F	50	22	100	19	46	48	A	•
	216-71272	TC50H100D22F	50	22	100	19	50	60	B	•
	216-71277	TC50H100D27F	50	27	100	21	55	78	C	•
	266-71256	TC50H100D32F	50	32	100	24	66	78	-	•
266-71276	TC50H100D40F	50	40	100	27	70	78	-	•	
H 160	216-71256	TC40H160D16F	40	16	160	17	39	-	-	•
	216-71260	TC40H160D22F	40	22	160	19	46	48	A	•
	266-71234	TC50H160D16F	50	16	160	17	38	-	-	•
	216-71268	TC50H160D22F	50	22	160	19	46	48	A	•
	216-71273	TC50H160D22F	50	22	160	19	50	60	B	•
	216-71278	TC50H160D27F	50	27	160	21	55	78	C	•
	266-71257	TC50H160D32F	50	32	160	24	66	78	-	•
266-71287	TC50H160D40F	50	40	160	27	70	78	-	•	
H 200	216-71257	TC40H200D16F	40	16	200	17	39	-	-	•
	216-71261	TC40H200D22F	40	22	200	19	46	48	A	•
	266-71250	TC50H200D16F	50	16	200	17	39	-	-	•
	216-71269	TC50H200D22F	50	22	200	19	46	48	A	•
	216-71274	TC50H200D22F	50	22	200	19	50	60	B	•
	216-71279	TC50H200D27F	50	27	200	21	55	78	C	•
	266-71258	TC50H200D32F	50	32	200	24	66	78	-	•
266-71288	TC50H200D40F	50	40	200	27	70	78	-	•	

A/Für Fräser D50 - B/Für Fräser D63 - C/Für Fräser D80

A/Suitable for milling cutters D50 - B/Suitable for milling cutters D63 - C/Suitable for milling cutters D80

A/подходит для фрез D50 - B/подходит для фрез D63 - C/подходит для фрез D80

A/Adaptes pour fraises D50 - B/Adaptes pour fraises D63 - C/Adaptes pour fraises D80

A/Adatti per frese D50 - B/Adatti per frese D63 - C/Adatti per frese D80

A/适用于 D50 铣刀 - B/适用于 D63 铣刀 - C/适用于 D80 铣刀

Ersatzteile • Spare parts • Pièces détachées • Componenti • Запасные части • 零件

D/D2	Cross Screw	Cross screw on enquiry	Tenon	Screw	Wrench
16	811-107003	811-107013	814-202280	811-101004	816-130002
22/46	811-107004	811-107014	814-202250	811-101011	816-130003
22/50	811-107004	811-107014	814-202260	811-101012	816-130003
27	811-107005	811-107015	814-202270	811-101017	816-130004
32	811-107006	811-107016	814-202290	811-101029	816-130005
40	811-107007	811-107017	814-202180	811-101028	816-130006



pag. 468-469



pag. 468-469



pag. 468-469

AUFSTECKFRÄSDORNE FÜR FRÄSER MIT QUERNUT
UND KÜHLMITTELZUFUHR MIT GRÖßEREM BUND
FACE MILL HOLDERS-TENONS DRIVE WITH INTERNAL
COOLANT SUPPLY WITH BIGGER FLANGE DIAMETER
ОПРАВКИ ДЛЯ НАСАДНЫХ ФРЕЗ С ВНУТРЕННЕЙ ПОДАЧЕЙ
СОЖ И УВЕЛИЧЕННЫМ ДИАМЕТРОМ КОРПУСА

MANDRINS PORTE-FRAISE-ENTRAÎNEMENT PAR TENONS
AVEC ARROSAGE INTERNE BRIDE AJOUTÉE
MANDRINI PORTAFRESE A TRASCINAMENTO FISSO
CON PASSAGGIO REFRIGERANTE CON FLANGIA MAGGIORATA
平面铣刀柄 - 凸榫驱动配备内部冷却剂供应带更大法兰直径

ISO 3937

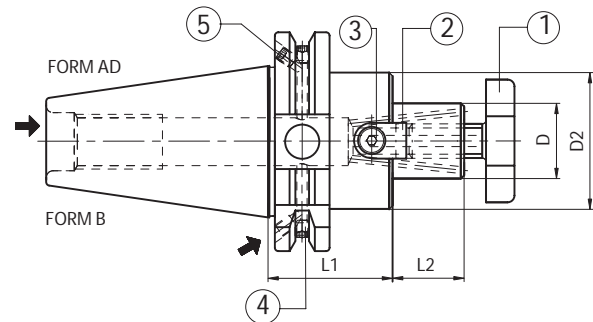



Code N.	Description	ISO	D	L1	L2	D2	G6,3 8000 RPM
216-71301	TC40H45D16F AD+B	40	16	45	17	38	•
216-71302	TC40H45D22F AD+B	40	22	45	19	48	•
216-71303	TC40H50D27F AD+B	40	27	50	21	58	•
216-71304	TC40H55D32F AD+B	40	32	55	24	78	•
216-71305	TC40H55D40F AD+B	40	40	55	27	88	•
216-71306	TC50H45D16F AD+B	50	16	45	17	38	•
216-71307	TC50H45D22F AD+B	50	22	45	19	48	•
216-71308	TC50H45D27F AD+B	50	27	45	21	58	•
216-71309	TC50H55D32F AD+B	50	32	55	24	78	•
216-71310	TC50H55D40F AD+B	50	40	55	27	88	•

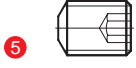

Ersatzteile • Spare parts • Pièces détachées • Componenti • Запасные части • 零件

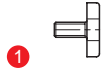
Tape	Screw	Quantity	Screw	Quantity
				
ISO 40	811-102002 M4X5	2	811-102002 M4X5	2
ISO 50	811-102001 M4X4	2	811-102010 M5X6	2

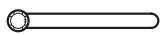
D	Cross screw	Tenon	Screw	Wrench
				
16	811-107003	814-202280	811-101004	816-130002
22	811-107004	814-202250	811-101011	816-130003
27	811-107005	814-202270	811-101018	816-130004
32	811-107006	814-202630	811-101029	816-130005
40	811-107007	814-202710	811-101029	816-130006

AUFSTECKFRÄSDORNE FÜR FRÄSER MIT QUERNUT UND
KÜHLMITTELZUFUHR-LANGE AUSFÜHRUNG
FACE MILL HOLDERS-TENONS DRIVE-WITH INTERNAL
COOLANT SUPPLY-LONG
ОПРАВКИ ДЛЯ НАСАДНЫХ ФРЕЗ С ВНУТРЕННЕЙ ПОДАЧЕЙ СОЖ.
УДЛИНЕННОЕ ИСПОЛНЕНИЕ

MANDRINS PORTE-FRAISE-ENTRAINEMENT PAR TENONS
AVEC ARROSAGE INTERNE-LONGUE
MANDRINI PORTAFRESE A TRASCINAMENTO FISSO
CON PASSAGGIO REFRIGERANTE-LUNGA
平面铣刀柄 - 凸榫驱动配备内部冷却剂供应加长



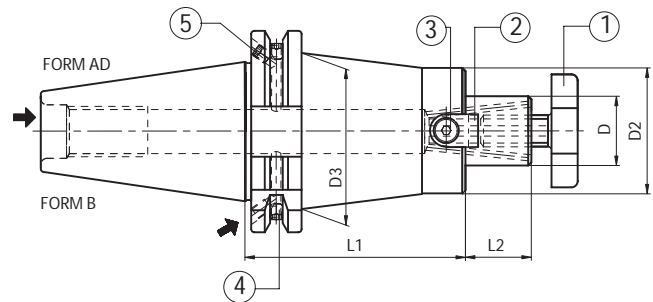

ISO 3937



Code N.	Description	ISO	D	L1	L2	D2	D3	G6,3 8000 RPM	
H 100	216-71321	TC40H100D16F AD+B	40	16	100	17	32	42	•
	216-71322	TC40H100D22F AD+B	40	22	100	19	40	49	•
	216-71323	TC40H100D27F AD+B	40	27	100	21	48	-	•
	216-71324	TC40H100D32F AD+B	40	32	100	24	58	-	•
	216-71326	TC40H100D40F AD+B	40	40	100	27	70	-	•
	216-71312	TC50H100D16F AD+B	50	16	100	17	32	42	•
	216-71313	TC50H100D22F AD+B	50	22	100	19	40	55	•
	216-71314	TC50H100D27F AD+B	50	27	100	21	48	60	•
	216-71315	TC50H100D32F AD+B	50	32	100	24	58	68	•
	216-71316	TC50H100D40F AD+B	50	40	100	27	70	-	•

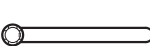

Ersatzteile • Spare parts • Pièces détachées • Componenti • Запасные части • 零件

Tape	Screw	Quantity	Screw	Quantity
				
ISO 40	811-102002 M4X5	2	811-102002 M4X5	2
ISO 50	811-102001 M4X4	2	811-102010 M5X6	2
D	Cross screw	Tenon	Screw	Wrench
				
16	811-107003	814-20214	811-101003	816-130002
22	811-107004	814-20215	811-101010	816-130003
27	811-107005	814-20216	811-101017	816-130004
32	811-107006	814-20217	811-101027	816-130005
40	811-107007	814-20218	811-101028	816-130006

AUFSTECKFRÄSERDORNE FÜR MESSERKÖPFE
FACE MILL HOLDER FOR FACE MILLING CUTTERS
ОПРАВКИ ДЛЯ ФЛАНЦЕВОГО КРЕПЛЕНИЯ ФРЕЗ

MANDRINS PORTE-FRAISE POUR FRAISES A SURFACER
MANDRINI PORTAFRESE PER FRESE A SPIANARE
平面铣刀柄-夹持端铣刀

DIN 6357

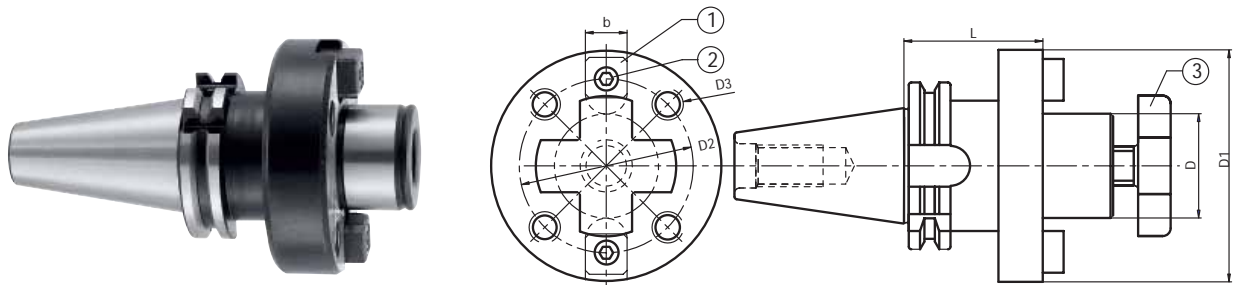

Code N.	Description	ISO	D	L	D1	D2	D3	b	G6,3 8000 RPM
▲ 216-21201	TC40H60D40	40	40	60	89	66.7	M12	15.9	•
▲ 216-21202	TC50H70D40	50	40	70	89	66.7	M12	15.9	•
216-21203	TC50H70D60	50	60	70	129	101.6	M16	25.4	•

▲ INKLUSIVE INNENSCHARUBE • SUPPLIED WITH INTERNAL SCREW • ПОСТАВЛЯЕТСЯ С ВНУТРЕННИМ ВИНТОМ
VIS INTERNE INCLUSE • FORNITO CON VITE CENTRALE INCLUSA • 供货时提供内部螺丝

Ersatzteile • Spare parts • Pièces détachées • Componenti • Запасные части • 零件

D	Tenon	Screw	Screw	Wrench
40	814-202080	811-101028	811-107007	816-130006
60	814-202120	811-101063	-	-

ZWISCHENHÜSLEN FÜR MORSEKEGEL MIT AUSTREIBBLAPPEN
MORSE TAPER ADAPTORS FOR DRILLS
ОПРАВКИ ДЛЯ КОНУСА МОРЗЕ С ЛАПКОЙ

DOUILLES POUR CONE MORSE A TENON
MANDRINI PORTAPUNTE ATTACCO CONO MORSE
莫氏锥度钻接头

DIN 69871 AD

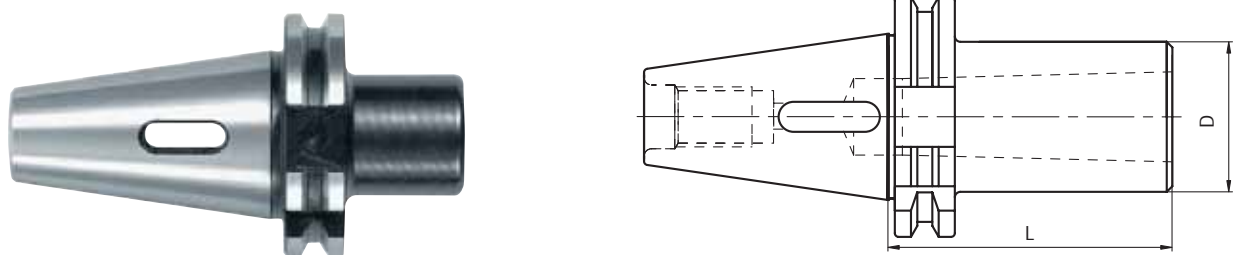

Code N.	Description	ISO	MORSE	D	L	G6,3 8000 RPM
212-41201	TC40H50CM1P	40	1	25	50	•
212-41202	TC40H50CM2P	40	2	32	50	•
212-41203	TC40H70CM3P	40	3	40	70	•
212-41204	TC40H95CM4P	40	4	48	95	•
212-41205	TC50H50CM1P	50	1	25	50	•
212-41206	TC50H60CM2P	50	2	32	60	•
212-41207	TC50H65CM3P	50	3	40	65	•
212-41208	TC50H95CM4P	50	4	48	95	•
212-41209	TC50H120CM5P	50	5	63	120	•

ZWISCHENHÜLSEN FÜR MORSEKegel MIT ANZUGSGEWINDE
MORSE TAPER ADAPTER WITH THREAD
ОПРАВКИ ДЛЯ КОНУСА МОРЗЕ С РЕЗЬБОЙ

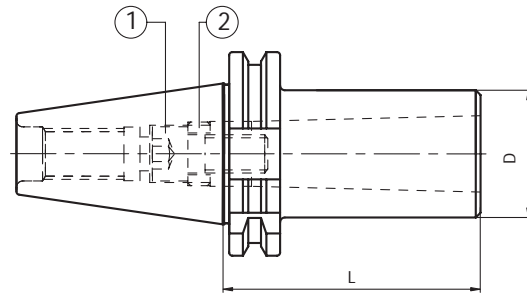

DOUILLES POUR CONE MORSE AVEC TARAUDAGE
MANDRINI PORTAFRESE ATTACCO CONO MORSE
螺纹莫氏锥度接头

DIN 228-2 FORM C

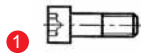
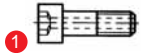

Code N.	Description	ISO	MORSE	D	L	G6,3 ⁸⁰⁰⁰ RPM
212-21201	TC40H50CM1F	40	1	25	50	•
212-21202	TC40H50CM2F	40	2	32	50	•
212-21203	TC40H70CM3F	40	3	40	70	•
212-21204	TC40H95CM4F	40	4	48	95	•
212-21205	TC50H45CM1F	50	1	25	45	•
212-21206	TC50H60CM2F	50	2	32	60	•
212-21207	TC50H65CM3F	50	3	40	65	•
212-21208	TC50H95CM4F	50	4	48	95	•
212-21209	TC50H120CM5F	50	5	63	120	•

Ersatzteile • Spare parts • Pièces détachées • Componenti • Запасные части • 零件

TC/MORSE	Screw (TCA)	On enquiry	Ring
			
40/1	811-101029	-	811-302030
40/2	811-111007	811-111038	811-302031
40/3	811-111008	811-401098	811-302032
40/4	811-111005	811-401083	811-302036
50/1	811-101029	-	811-302030
50/2	811-101054	811-401084	811-302032
50/3	811-101065	811-401085	811-302032
50/4	811-401037	811-401086	811-302036
50/5	811-101092	811-401087	811-302034

ZWISCHENHÜLSEN FÜR MORSEKEGEL MIT ANZUGSGEWINDE
MORSE TAPER ADAPTER WITH THREAD
ОПРАВКИ ДЛЯ КОНУСА МОРЗЕ С РЕЗЬБОЙ



DOUILLES POUR CONE MORSE AVEC TARAUDAGE
MANDRINI PORTAFRESE ATTACCO CONO MORSE
螺纹莫氏锥度接头

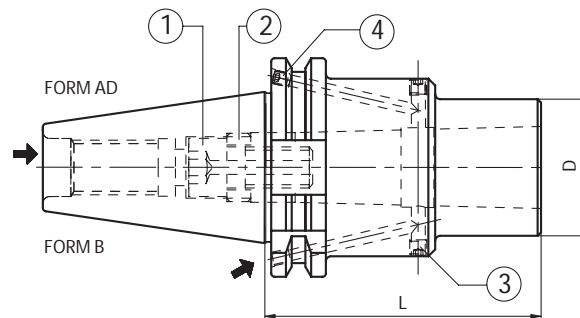

DIN 228-2 FORM C



Code N.	Description	ISO	MORSE	D	L	G6,3 8000 RPM
212-31321	TC40H50CM2F AD+B	40	2	32	50	•
212-31322	TC40H70CM3F AD+B	40	3	40	70	•
212-31323	TC40H95CM4F AD+B	40	4	48	95	•
212-31324	TC50H60CM2F AD+B	50	2	32	60	•
212-31325	TC50H65CM3F AD+B	50	3	40	65	•
212-31326	TC50H95CM4F AD+B	50	4	48	95	•

Ersatzteile • Spare parts • Pièces détachées • Componenti • Запасные части • 零件

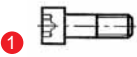
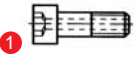
Tape/Morse	Screw	Quantity	Screw	Quantity
				
40/2	811-102002 M4X5	2	811-102002 M4X5	2
40/3,4	-	-	811-102002 M4X5	2
50/2,3	811-102001 M4X4	2	811-102010 M5X6	2
50/4,5	-	-	811-102010 M5X6	2

TC/MORSE	Screw (TCA)	On enquiry	Ring
			
40/2	811-111007	811-111038	811-302031
40/3	811-111008	811-401098	811-302032
40/4	811-111005	811-401083	811-302036
50/2	811-101054	811-401084	811-302032
50/3	811-101065	811-401085	811-302032
50/4	811-401037	811-401086	811-302036

ZWISCHENHÜSLEN FÜR MORSEKEGEL
MIT AUSTREIBBLAPPEN ODER ANZUGSGEWINDE
MORSE TAPER ADAPTORS FOR DRILLS AND MILLS
ОПРАВКИ ДЛЯ КОНУСОВ МОРЗЕ С ЛАПКОЙ И С РЕЗЬБОЙ

DOUILLES POUR CONE MORSE A TENON
ET AVEC TARAUDAGE
MANDRINI PORTAPUNTE-PORTAFRESE ATTACCO CONO MORSE
莫氏锥度钻铣接头

DIN 228-2 FORM C/D

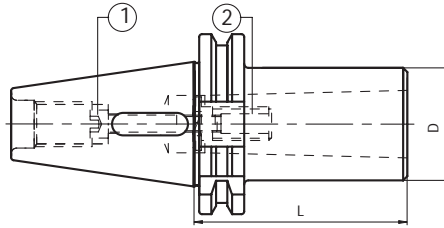

Kombi Version



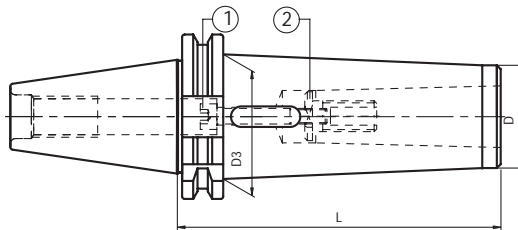

	Code N.	Description	ISO	MORSE	D	L	G6,3 8000 RPM
STANDARD	212-61201	TC40H50CM1P/F	40	1	25	50	•
	212-61202	TC40H60CM2P/F	40	2	32	60	•
	212-61203	TC40H75CM3P/F	40	3	40	75	•
	212-61205	TC50H45CM1P/F	50	1	25	45	•
	212-61206	TC50H60CM2P/F	50	2	32	60	•
	212-61207	TC50H65CM3P/F	50	3	40	65	•
	212-61208	TC50H95CM4P/F	50	4	48	95	•
	212-61209	TC50H120CM5P/F	50	5	63	120	•



Kombi Version

	Code N.	Description	ISO	MORSE	D	D3	L	G6,3 8000 RPM
EXTENDED	212-61210	TC40H115CM1P/F	40	1	18	25	115	•
	212-61211	TC40H125CM2P/F	40	2	25	32	125	•
	212-61212	TC40H140CM3P/F	40	3	33	40	140	•
	212-61214	TC50H120CM1P/F	50	1	18	25	120	•
	212-61215	TC50H140CM2P/F	50	2	25	32	140	•
	212-61216	TC50H150CM3P/F	50	3	33	40	150	•
	212-61217	TC50H180CM4P/F	50	4	40	48	180	•
	212-61218	TC50H220CM5P/F	50	5	55	63	220	•

Ersatzteile • Spare parts • Pièces détachées • Componenti • Запасные части • 零件

Code N.	Screw	Ring	Code N.	Screw	Ring
					
212-61201	811-101033	-	212-61210	811-101037	-
212-61202	811-401018	-	212-61211	811-401015	-
212-61203	811-101034	811-302006	212-61212	811-101081	811-302006
212-61205	811-101033	-	212-61214	811-101077	-
212-61206	811-101057	-	212-61215	811-101078	-
212-61207	811-101070	-	212-61216	811-101079	-
212-61208	811-401016	-	212-61217	811-401030	-
212-61209	811-101071	811-302008	212-61218	811-101080	811-302008

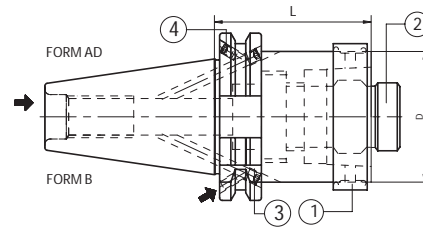

ZWISCHENHÜLSEN SK X HSK A+C - MANUELLES SPANNSYSTEM
 TAPER ADAPTER SA X HSK A+C - MANUAL CLAMPING
 ПЕРЕХОДНЫЕ ОПРАВКИ SK - HSK A+C - РУЧНАЯ УСТАНОВКА

DOUILLES INTERMEDIAIRES SA X HSK A+C - SERRAGE MANUEL
 MANDRINI RIDUZIONE DA TC A HSK A+C - CHIUSURA MANUALE
 SA X HSK A+C 锥度接头 - 手动夹紧



Code N.	Description	ISO	HSK	D	L	¹ Ring (complete)	² Locking unit (complete)
212-91305	TC40H50HSK40 AD+B	40	40	40	50	H40A-AN	H40A-UBL
212-91301	TC40H60HSK50 AD+B	40	50	50	60	H50A-AN	H50A-UBL
212-91302	TC40H80HSK63 AD+B	40	63	63	80	H63A-AN	H63A-UBL
212-91306	TC50H50HSK40 AD+B	50	40	40	50	H40A-AN	H40A-UBL
212-91303	TC50H50HSK50 AD+B	50	50	50	50	H50A-AN	H50A-UBL
212-91304	TC50H60HSK63 AD+B	50	63	63	60	H63A-AN	H63A-UBL

Ersatzteile • Spare parts • Pièces détachées • Componenti • Запасные части • 零件

Tappe	Screw	Quantity	Screw	Quantity
				
ISO 40	811-102002 M4X5	2	811-102002 M4X5	2
ISO 50	811-102001 M4X4	2	811-102010 M5X6	2

ZWISCHENHÜLSEN SK X SK
 ISO TAPER ADAPTORS
 ПЕРЕХОДНЫЕ ОПРАВКИ SK - SK



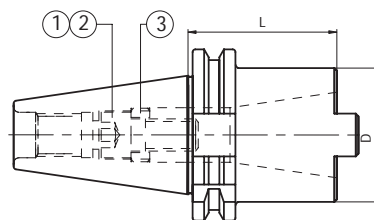

DOUILLES INTERMEDIAIRES TC X SA
 MANDRINI RIDUZIONE E PROLUNGHE DA DIN69871 A DIN2080/DIN69871/MAS403BT
 ISO 锥度接头



DIN 69871 AD

Code N.	Description	ISO	ISO	D	L	G6,3 8000 RPM
212-11204	TC40H60ISO30/TC30	40	30	49	60	•
212-11213	TC40H100ISO40/TC40	40	40	68	100	•
212-11201	TC50H70ISO40/TC40	50	40	68	70	•
212-11214	TC50H120ISO50/TC50	50	50	100	120	•

Ersatzteile • Spare parts • Pièces détachées • Componenti

OUTSIDE	INSIDE	Screw (ISO)	Screw (TC)	Ring	Wrench
					
40	30	811-401085	811-401146	811-302032	816-20206002
40	40	811-401147	811-401150	811-302036	816-20207002
50	40	811-401147	811-401150	811-302036	816-20207002
50	50	811-401151	811-401152	811-302047	816-20209002

Verschlusschraube für DIN69871/MAS BT/DIN2080 wird mitgeliefert und ist durchbohrt
 Supplied with a bored screw DIN69871/MAS BT/DIN2080
 Livré avec une vis de serrage DIN69871/MAS BT/DIN2080 percée
 In dotazione vite per chiusura DIN69871/MAS BT/DIN2080 forata
 Поставляется с винтом с отверстием для DIN69871/MAS BT/DIN2080
 提供 DIN69871/MAS BT/DIN2080 无铆螺钉一个

SPANNZANGENFUTTER ER TYP
ER COLLET CHUCK
ЦАНГОВЫЕ ПАТРОНЫ ER
MANDRINS A PINCES TYPE ER
MANDRINI PORTAPINZA TIPO ER
ER 弹簧夹头

DIN 6499

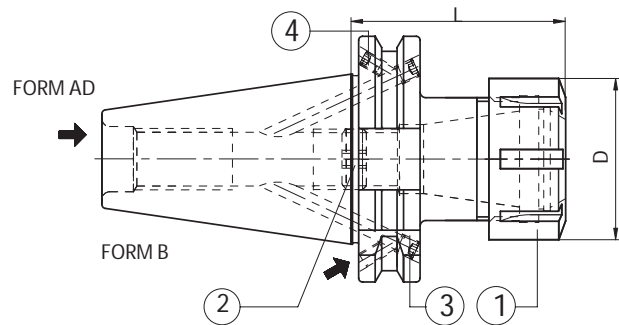



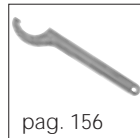

Code N.	Description	ISO	ER	D	L	G2,5 25000 RPM
214-91301	TC40H70ER16 AD+B	40	16	32	70	•
214-91302	TC40H70ER25 AD+B	40	25	42	70	•
214-91303	TC40H70ER32 AD+B	40	32	50	70	•
214-91304	TC40H70ER40 AD+B	40	40	63	70	•
214-91305	TC50H70ER25 AD+B	50	25	42	70	•
214-91306	TC50H70ER32 AD+B	50	32	50	70	•
214-91307	TC50H80ER40 AD+B	50	40	63	80	•

Zubehör
Accessories
Accessoires
Accessori
Принадлежности
零件



High balanced

Ersatzteile • Spare parts • Pièces détachées • Componenti • Запасные части • 零件

Type	Screw	Quantity	Screw	Quantity	ER	Nut	Stop screw
							
ISO 40	811-102002 M4X5	2	811-102002 M4X5	2	16	812-203069	811-303119
ISO 50	811-102001 M4X4	2	811-102010 M5X6	2	25	812-203070	811-303121
					32	812-203071	811-303118
					40	812-203072	811-303122

SPANNZANGENFUTTER ER TYP-LANG ER COLLET CHUCK-LONG ЦАНГОВЫЕ ПАТРОНЫ ER. УДЛИНЕННОЕ ИСПОЛНЕНИЕ MANDRINS A PINCES TYPE ER-SERIE LONGUE MANDRINI PORTAPINZA TIPO ER-SERIE LUNGA ER 弹簧夹头-加长

DIN 6499

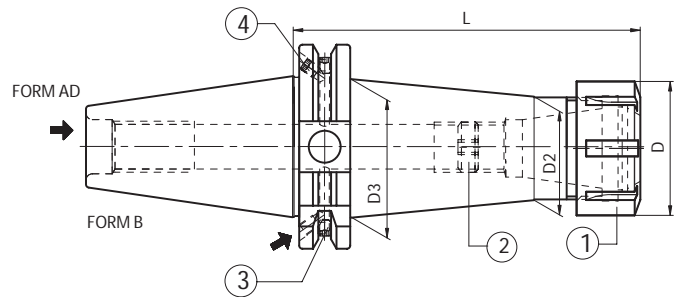





	Code N.	Description	ISO	ER	D	L	D2	D3	G2,5 25000 RPM
H 100	214-91308	TC40H100ER16 AD+B	40	16	32	100	22	32	•
	214-91309	TC40H100ER25 AD+B	40	25	42	100	32	42	•
	214-91310	TC40H100ER32 AD+B	40	32	50	100	40	50	•
	214-91311	TC40H100ER40 AD+B	40	40	63	100	50	50	•
	214-91312	TC50H100ER16 AD+B	50	16	32	100	22	32	•
	214-91313	TC50H100ER25 AD+B	50	25	42	100	32	42	•
	214-91314	TC50H100ER32 AD+B	50	32	50	100	40	50	•
	214-91315	TC50H100ER40 AD+B	50	40	63	100	50	63	•
H 160	214-91316	TC40H160ER16 AD+B	40	16	32	160	22	32	•
	214-91317	TC40H160ER25 AD+B	40	25	42	160	32	42	•
	214-91318	TC40H160ER32 AD+B	40	32	50	160	40	50	•
	214-91319	TC40H160ER40 AD+B	40	40	63	160	50	50	•

Zubehör
Accessories
Accessoires
Accessori
Принадлежности
零件



High balanced

Ersatzteile • Spare parts • Pièces détachées • Componenti • Запасные части • 零件

Tap	Screw	Quantity	Screw	Quantity	ER	Nut	Stop screw
							
ISO 40	811-102002 M4X5	2	811-102002 M4X5	2	16	812-203069	811-303119
ISO 50	811-102001 M4X4	2	811-102010 M5X6	2	25	812-203070	811-303121
					32	812-203071	811-303118
					40	812-203072	811-303122

SPANNZANGENFUTTER ER MINI MANDRINS A PINCES TYPE ER MINI
 ER MINI COLLET CHUCK MANDRINI PORTAPINZA TIPO ER MINI EXTRA SOTTILI
 ЦАНГОВЫЕ МИНИ-ПАТРОНЫ ER ER 迷你弹簧夹头

DIN 6499

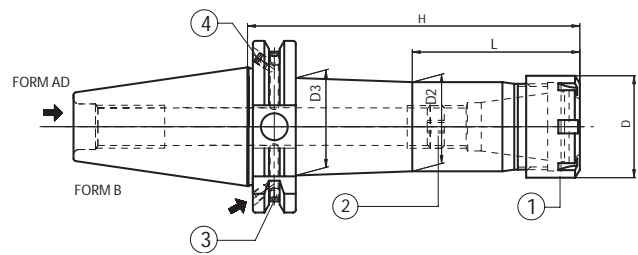

Code N.	Description	ISO	ER	D	H	L	D2	D3	G6,3 12000 RPM
214-91333	TC40H70ER11M AD+B	40	11M	16	70	22	14	20	•
214-91334	TC40H100ER11M AD+B	40	11M	16	100	40	14	21	•
214-91335	TC40H160ER11M AD+B	40	11M	16	160	50	14	29	•
214-91336	TC40H70ER16M AD+B	40	16M	22	70	27	20	26	•
214-91337	TC40H100ER16M AD+B	40	16M	22	100	47	20	27	•
214-91338	TC40H160ER16M AD+B	40	16M	22	160	97	20	27	•
214-91348	TC40H70ER20M AD+B	40	20M	28	70	-	26	-	•
214-91349	TC40H100ER20M AD+B	40	20M	28	100	48	26	31	•
214-91350	TC40H160ER20M AD+B	40	20M	28	160	98	26	33	•
214-91339	TC40H70ER25M AD+B	40	25M	35	70	-	33	-	•
214-91340	TC40H100ER25M AD+B	40	25M	35	100	-	33	-	•
214-91341	TC40H160ER25M AD+B	40	25M	35	160	103	33	36	•
214-91342	TC50H70ER16M AD+B	50	16M	22	70	-	22	-	•
214-91343	TC50H100ER16M AD+B	50	16M	22	100	47	22	28	•
214-91344	TC50H160ER16M AD+B	50	16M	22	160	97	22	30	•
214-91351	TC50H70ER20M AD+B	50	20M	28	70	-	28	-	•
214-91352	TC50H100ER20M AD+B	50	20M	28	100	48	28	33	•
214-91353	TC50H160ER20M AD+B	50	20M	28	160	98	28	35	•
214-91345	TC50H70ER25M AD+B	50	25M	35	70	-	35	-	•
214-91346	TC50H100ER25M AD+B	50	25M	35	100	-	35	-	•
214-91347	TC50H160ER25M AD+B	50	25M	35	160	103	35	42	•

Zubehör
 Accessories
 Accessoires
 Accessori
 Принадлежности
 零件



Slim Line

Ersatzteile • Spare parts • Pièces détachées • Componenti • Запасные части • 零件

Type	Screw	Quantity	Screw	Quantity	ER	Nut	Stop screw
ISO 40	811-102002 M4X5	2	811-102002 M4X5	2	11M	812-203012	811-303081
ISO 50	811-102001 M4X4	2	811-102010 M5X6	2	16M	812-203013	811-303119
					20M	812-203014	811-303120
					25M	812-203015	811-303121

SPANNZANGENFUTTER ER TYP MANDRINS A PINCES TYPE ER
 ER COLLET CHUCK MANDRINI PORTAPINZA TIPO ER
 ЦАНГОВЫЕ ПАТРОНЫ ER ER 弹簧夹头

DIN 6499

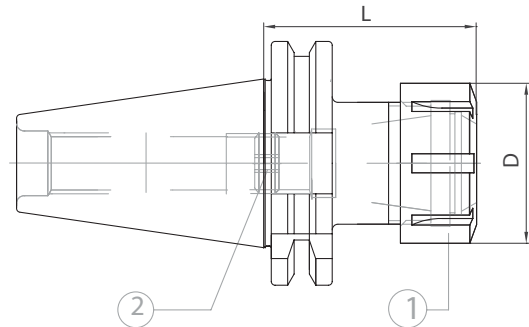

Code N.	Description	ISO	ER	D	L	G6,3 12000 RPM
214-31211	TC30H55ER16	30	16	32	55	•
214-31212	TC30H55ER25	30	25	42	55	•
214-31228	TC30H60ER32	30	32	50	60	•
214-31241	TC40H70ER16	40	16	32	70	•
214-31201	TC40H70ER25	40	25	42	70	•
214-31202	TC40H70ER32	40	32	50	70	•
214-31215	TC40H70ER40	40	40	63	70	•
264-31233	TC50H70ER16	50	16	32	70	•
214-31250	TC50H70ER25	50	25	42	70	•
214-31203	TC50H70ER32	50	32	50	70	•
214-31204	TC50H80ER40	50	40	63	80	•

Ersatzteile • Spare parts • Pièces détachées • Componenti • Запасные части • 零件

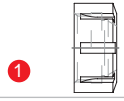
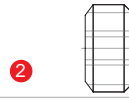
ER	Nut	Stop screw
		
16	812-203005	811-303119
25	812-203001	811-303121
32	812-203002	811-303118
40	812-203003	811-303122

SPANNZANGENFUTTER ER TYP-LANG
ER COLLET CHUCK-LONG
ЦАНГОВЫЕ ПАТРОНЫ ER. УДЛИНЕННОЕ ИСПОЛНЕНИЕ

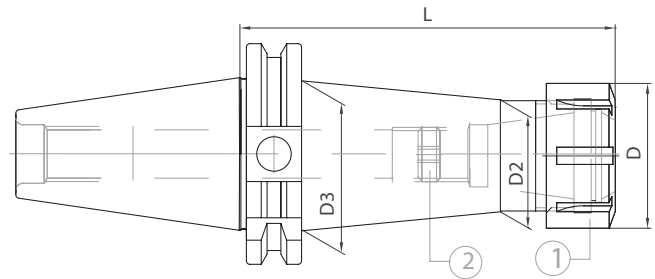

MANDRINS A PINCES TYPE ER-SERIE LONGUE
MANDRINI PORTAPINZA TIPO ER- SERIE LUNGA
ER 弹簧夹头-加长

DIN 6499



Code N.	Description	ISO	ER	D	L	D2	D3	G6,3 ¹²⁰⁰⁰ RPM
214-31242	TC40H100ER16	40	16	32	100	22	31	•
214-31232	TC40H100ER25	40	25	42	100	32	41	•
214-31230	TC40H100ER32	40	32	50	100	40	44	•
214-31286	TC40H100ER40	40	40	63	100	50	50	•

Ersatzteile • Spare parts • Pièces détachées • Componenti • Запасные части • 零件

ER	Nut	Stop screw
		
16	812-203005	811-303119
25	812-203001	811-303121
32	812-203002	811-303118
40	812-203003	811-303122

SPANNZANGENFUTTER ER TYP MANDRINS A PINCES TYPE ER
 ER COLLET CHUCK MANDRINI PORTAPINZA TIPO ER
 ЦАНГОВЫЕ ПАТРОНЫ ER ER 弹簧夹头

DIN 6499

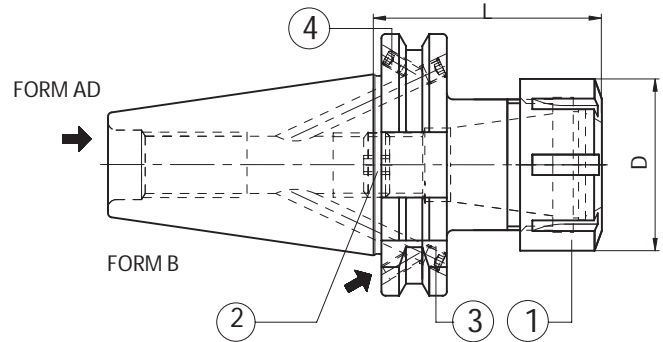

	Code N.	Description	ISO	ER	D	L	G6,3 12000 RPM
STANDARD	214-31362	TC40H70ER16 AD+B	40	16	32	70	•
	214-31329	TC40H70ER25 AD+B	40	25	42	70	•
	214-31331	TC40H70ER32 AD+B	40	32	50	70	•
	214-31333	TC40H70ER40 AD+B	40	40	63	70	•
	214-31381	TC50H70ER16 AD+B	50	16	32	70	•
	214-31341	TC50H70ER25 AD+B	50	25	42	70	•
	214-31335	TC50H70ER32 AD+B	50	32	50	70	•
	214-31338	TC50H80ER40 AD+B	50	40	63	80	•

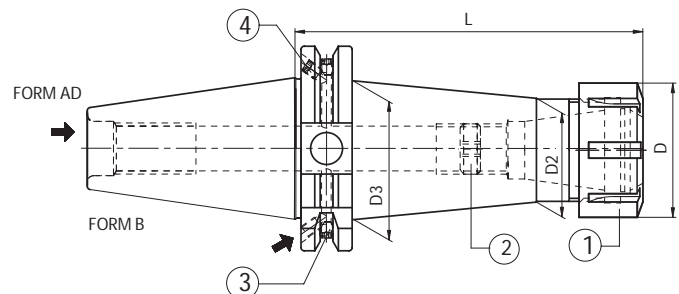

	Code N.	Description	ISO	ER	D	L	D2	D3	G6,3 12000 RPM
H 100	214-31363	TC40H100ER16 AD+B	40	16	32	100	22	32	•
	214-31347	TC40H100ER25 AD+B	40	25	42	100	32	42	•
	214-31348	TC40H100ER32 AD+B	40	32	50	100	40	50	•
	214-31364	TC40H100ER40 AD+B	40	40	63	100	50	50	•
	214-31365	TC50H100ER16 AD+B	50	16	32	100	22	32	•
	214-31342	TC50H100ER25 AD+B	50	25	42	100	32	42	•
	214-31336	TC50H100ER32 AD+B	50	32	50	100	40	50	•
	214-31339	TC50H100ER40 AD+B	50	40	63	100	50	63	•

- * Ausführung Form AD
- * Execution form AD
- * Forme AD
- * Forma AD
- * Исполнение AD
- * 执行形式 AD

Zubehör
 Accessories
 Accessoires
 Accessori
 Принадлежности
 零件



SPANNZANGENFUTTER ER TYP-LÄNGE AUSFÜHRUNG
ER COLLET CHUCK-LONG
ЦАНГОВЫЕ ПАТРОНЫ ER. УДЛИНЕННОЕ ИСПОЛНЕНИЕ



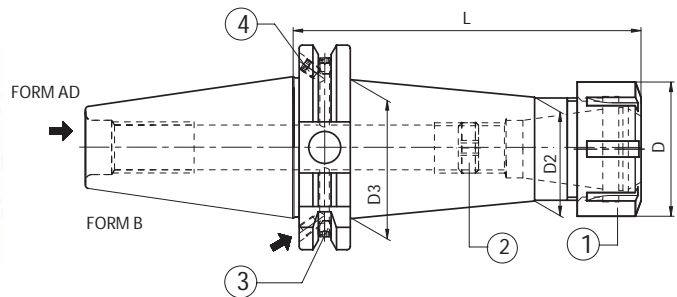

MANDRINS A PINCES TYPE ER-SERIE LONGUE
MANDRINI PORTAPINZA TIPO ER-SERIE LUNGA
ER 弹簧夹头-加长

DIN 6499



	Code N.	Description	ISO	ER	D	L	D2	D3	G6,3 8000 RPM
H 160	214-31359	TC40H160ER16 AD+B	40	16	32	160	22	32	•
	214-31345	TC40H160ER25 AD+B	40	25	42	160	32	42	•
	214-31346	TC40H160ER32 AD+B	40	32	50	160	40	50	•
	214-31366	TC40H160ER40 AD+B	40	40	63	160	50	50	•
	214-31367	TC50H160ER16 AD+B	50	16	32	160	22	32	•
	214-31368	TC50H160ER25 AD+B	50	25	42	160	32	42	•
	214-31337	TC50H160ER32 AD+B	50	32	50	160	40	50	•
	214-31340	TC50H160ER40 AD+B	50	40	63	160	50	63	•
H 200	214-31369	TC40H200ER16 AD+B	40	16	32	200	22	32	•
	214-31370	TC40H200ER25 AD+B	40	25	42	200	32	42	•
	214-31371	TC40H200ER32 AD+B	40	32	50	200	40	50	•
	214-31372	TC40H200ER40 AD+B	40	40	63	200	50	50	•
	214-31373	TC50H200ER16 AD+B	50	16	32	200	22	32	•
	214-31374	TC50H200ER25 AD+B	50	25	42	200	32	42	•
	214-31375	TC50H200ER32 AD+B	50	32	50	200	40	50	•
	214-31376	TC50H200ER40 AD+B	50	40	63	200	50	63	•

Ersatzteile • Spare parts • Pièces détachées • Componenti • Запасные части • 零件

Tape	Screw	Quantity	Screw	Quantity	ER	Nut	Stop screw
							
ISO 40	811-102002 M4X5	2	811-102002 M4X5	2	16	812-203005	811-303119
ISO 50	811-102001 M4X4	2	811-102010 M5X6	2	25	812-203001	811-303121
					32	812-203002	811-303118
					40	812-203003	811-303122

Zubehör
Accessories
Accessoires
Accessori
Принадлежности
零件



SPANNZANGENFUTTER EOC TYP ER COLLET CHUCK ЦАНГОВЫЕ ПАТРОНЫ EOC MANDRINS A PINCES TYPE EOC MANDRINI PORTAPINZA TIPO EOC ER 弹簧夹头

DIN 6388

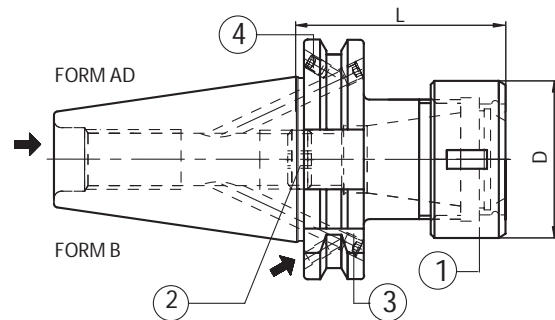



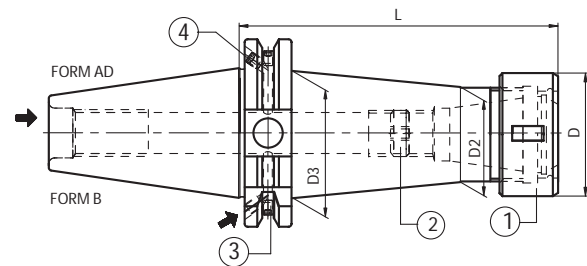

Code N.	Description	ISO	EOC	D	L	G6,3 12000 RPM
214-11320	TC40H70EOC16 AD+B	40	16	43	70	•
214-11321	TC40H70EOC25 AD+B	40	25	60	70	•
214-11322	TC50H70EOC25 AD+B	50	25	60	70	•
214-11323	TC50H80EOC32 AD+B	50	32	72	80	•

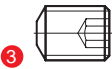

Code N.	Description	ISO	EOC	D	L	D2	D3	G6,3 8000 RPM
H130 214-11324	TC40H130EOC16 AD+B	40	16	43	130	33	40	•
214-11325	TC40H130EOC25 AD+B	40	25	60	130	48	49	•
214-11326	TC50H130EOC25 AD+B	50	25	60	130	48	58	•
214-11327	TC50H130EOC32 AD+B	50	32	72	130	60	62	•

Ersatzteile • Spare parts • Pièces détachées • Componenti • Запасные части • 零件

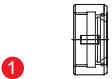
Tape	Screw	Quantity	Screw	Quantity
				
ISO 40	811-102002 M4X5	2	811-102002 M4X5	2
ISO 50	811-102001 M4X4	2	811-102010 M5X6	2

EOC	Nut	Stop screw	Wrench
			
16	GOC16	811-303121	816-203033
25	GOC25	811-303123	816-203034
32	GOC32	811-303123	816-203036

Zubehör
Accessories
Accessoires
Accessori
Принадлежности
零件

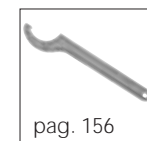



SPANNZANGENFUTTER ER TYP-LÄNGE EXTRAKURZ
ER COLLET CHUCK WITH INSIDE NUT
ЦАНГОВЫЕ ПАТРОНЫ ER С ВНУТРЕННЕЙ ГАЙКОЙ

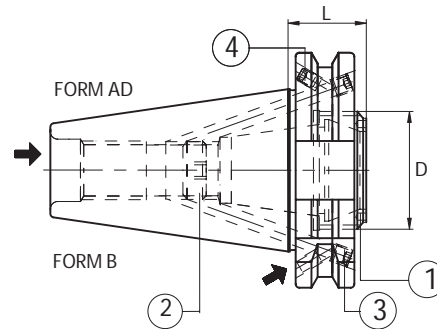

MANDRINS COURTS A PINCES TYPE ER
MANDRINI PORTAPINZA TIPO ER EXTRACORTI
ER 弹簧夹头带内部螺母



Code N.	Description	ISO	ER	D	L	G6,3 12000 RPM
214-31377	TC40H21ER25A AD+B	40	25	32	21	•
*264-31215	TC40H21ER32A	40	32	40	21	•
214-31378	TC50H21ER32A AD+B	50	32	40	21	•

Ersatzteile • Spare parts • Pièces détachées • Componenti • Запасные части • 零件

Tape	Screw	Quantity	Screw	Quantity
				
ISO 40	811-102002 M4X5	2	811-102002 M4X5	2
ISO 50	811-102063 M5X4	2	811-102010 M5X6	2

ER	Nut	Stop screw	Wrench
			
25A	812-203057	811-303121	CHER25EX
32A	812-203032	811-303118	CHER32EX

- * Ausführung Form AD
- * Execution form AD
- * Forme AD
- * Forma AD
- * Исполнение AD
- * 执行形式 AD

DIN 69871 A

BOHRFUTTERAUFNAHMEN
ARBORS FOR DRILL CHUCKS
ОПРАВКИ ДЛЯ СВЕРЛИЛЬНЫХ ПАТРОНОВ

ARBRES POUR MANDRINS DE PERCAGE
ATTACCO PER MANDRINI PORTAPUNTE
钻夹头刀杆

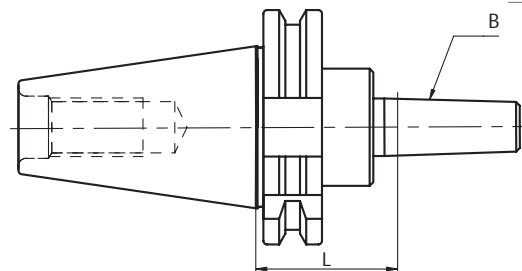

DIN 238

Code N.	Description	ISO	B	L	G6,3 8000 RPM
216-31201	TC40H40B16	40	16	40	•
216-31202	TC40H40B18	40	18	40	•
216-31203	TC50H40B16	50	16	40	•
216-31204	TC50H40B18	50	18	40	•

OPERATING MANUAL FOR HYDRAULIC EXPANSION CHUCKS MANUALE OPERATIVO PER L'UTILIZZO DEI MANDRINI IDRAULICI
 ИНСТРУКЦИЯ ПО ПРИМЕНЕНИЮ ГИДРАВЛИЧЕСКИХ ПАТРОНОВ

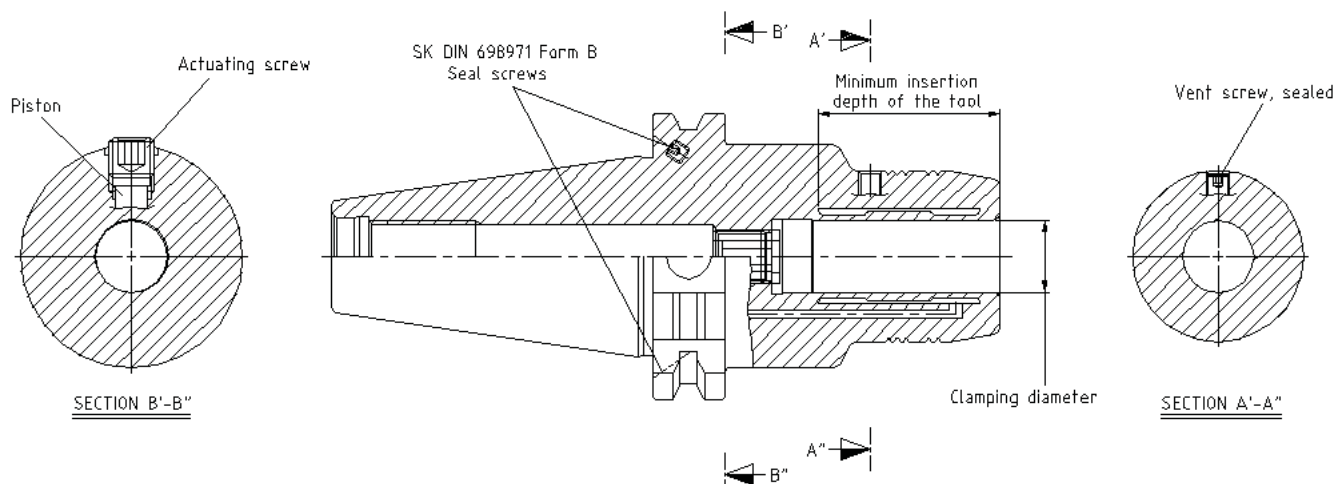

- Please follow our operating instruction carefully to save time and avoid problems
Пожалуйста, следуйте нашим инструкциям, чтобы избежать проблем и потери времени.
 Raccomandiamo di seguire le nostre istruzioni operative per risparmiare tempo ed evitare problemi

Chart of technical data

Таблица с техническими характеристиками:

Tabella delle informazioni tecniche

Chuck Diameter (HC)	Shaft Clamping	Depending on the mounting shank (max RPM)	Minimum clamping length (mm)	Operating temperature	Max coolant pressure (bar)	Moment (Nm)
HC6	6 hb	40.000	27	20-50	80	8 Nm
HC8	8 hb	40.000	27	20-50	80	15 Nm
HC10	10 hb	40.000	32	20-50	80	30 Nm
HC12	12 hb	40.000	37	20-50	80	45 Nm
HC14	14 hb	40.000	37	20-50	80	75 Nm
HC16	16 hb	40.000	42	20-50	80	120 Nm
HC18	18 hb	40.000	42	20-50	80	170 Nm
HC20	20 hb	40.000	42	20-50	80	230 Nm
HC25	25 hb	25.000	48	20-50	80	300 Nm
HC32	32 hb	25.000	55	20-50	80	400 Nm

- The clamping force must be checked periodically. We recommend to check it before initial use and approximately after 100 operations or every 3 months.

Усилие зажима необходимо периодически проверять. Мы рекомендуем производить проверку перед первым использованием, далее примерно каждые 100 операций или каждые 3 месяца.

La verifica della forza di serraggio deve essere fatta periodicamente. Si raccomanda di controllarla prima dell'utilizzo e dopo circa 100 operazioni o ogni 3 mesi

ATTENTION / **ВНИМАНИЕ** / ATTENZIONE

- When tools or endmills are clamped into the hydraulic chucks, be sure that oils and dust are completely removed from the internal surface of the hydraulic chuck and the external surface of the tool

При установке инструмента в гидropатроне, убедитесь, что на внутренней поверхности патрона и внешней поверхности инструмента нет масла и пыли.

Quando si montano gli utensili o le frese nel mandrino idraulico, la superficie interna del mandrino idraulico e quella esterna dell'utensile devono essere pulite da oli, polveri e residui

HYDRO-DEHNSPANNFUTTER FÜR WERKZEUGE MIT ZYLINDERSCHAFT
 HYDRO-EXPANSION CHUCKS FOR TOOLS WITH CYLINDRICAL SHANK
 ГИДРАВЛИЧЕСКИЕ ПАТРОНЫ ДЛЯ ИНСТРУМЕНТА
 С ЦИЛИНДРИЧЕСКИМ ХВОСТОВИКОМ

MANDRINS HYDRO-EXPANSIBLES POUR OUTILS
 A QUEUE CYLINDRIQUE
 MANDRINI IDRAULICI PER UTENSILI ATTACCO CILINDRICO
 适用圆柱刀柄的液压膨胀夹头

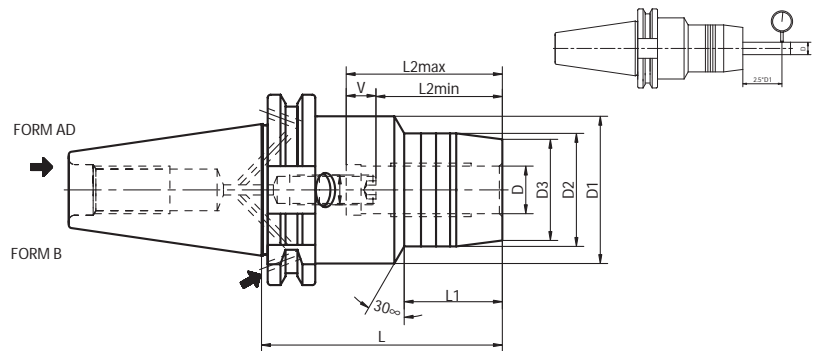

Code N.	Description	ISO	D	D1	D2	L	L1	L2 min	L2 max	V	M	G2,5 25.000
252-11305	SK40-HC6-80.5	40	6	49,5	26	80,5	29,5	27	37	10	M5*0.8	•
252-11307	SK40-HC8-80.5	40	8	49,5	28	80,5	30	27	37	10	M6*1.0	•
252-11309	SK40-HC10-80.5	40	10	49,5	30	80,5	35	31	41	10	M8*1.0	•
252-11311	SK40-HC12-80.5	40	12	49,5	32	80,5	40	36	46	10	M10*1.0	•
252-11313	SK40-HC16-80.5	40	16	49,5	38	80,5	45	39	49	10	M12*1.0	•
252-11315	SK40-HC20-80.5	40	20	49,5	42	80,5	47	41	51	10	M16*1.0	•
252-11317	SK40-HC25-80.5	40	25	63	55	80,5	28	47	57	10	M16*1.0	•
252-11318	SK40-HC32-80.5	40	32	70	63	80,5	25,5	51	61	10	M16*1.0	•
252-11319	SK50-HC6-80.5	50	6	49,5	26	80,5	29,5	27	37	10	M5*0.8	•
252-11320	SK50-HC8-80.5	50	8	49,5	28	80,5	30	27	37	10	M6*1.0	•
252-11321	SK50-HC10-80.5	50	10	49,5	30	80,5	35	31	41	10	M8*1.0	•
252-11322	SK50-HC12-80.5	50	12	49,5	32	80,5	40	36	46	10	M10*1.0	•
252-11323	SK50-HC16-80.5	50	16	49,5	38	80,5	45	39	49	10	M12*1.0	•
252-11324	SK50-HC20-80.5	50	20	49,5	42	80,5	42	41	51	10	M16*1.0	•
252-11331	SK50-HC25-100	50	25	63	55	100	48	47	57	10	M16*1.0	•
252-11332	SK50-HC32-100	50	32	70	63	100	61	51	61	10	M16*1.0	•

High quality

Code N.	Description	ISO	D	D1	D2	L	L1	L2 min	L2 max	V	M	G6,3 15000
252-11325	SK40-G20CS-64.5	40	20	49,5	-	64,5	-	41	51	10	M16*1.0	•
252-11326	SK50-G32CS-81	50	32	72	-	81	-	51	61	10	M16*1.0	•

Zubehör
 Accessories
 Accessoires
 Accessori
 Принадлежности
 零件



Short Heavy Design

KRAFTSPANNFUTTER MANDRINS A FORT SERRAGE
 MILLING CHUCK MANDRINI A FORTE SERRAGGIO
 УСИЛЕННЫЕ ОПРАВКИ 铣夹头

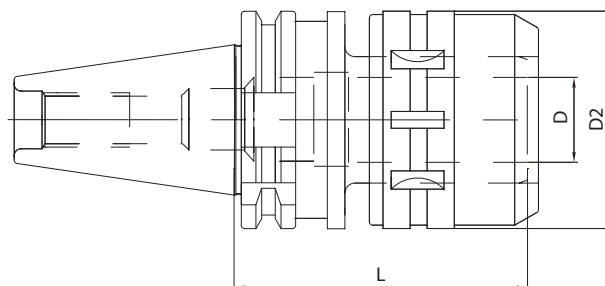

Code N.	Description	ISO	D	D2	L	G6,3 ¹²⁰⁰⁰ RPM
214-01301	TC40H105C20	40	20	54	105	-
214-01302	TC40H105C32	40	32	72	105	-
214-01304	TC50H105C20	50	20	54	105	-
214-01305	TC50H105C32	50	32	72	105	-
214-01306	TC50H135C32	50	32	72	135	-

INKLUSIVE SPANNSCHLÜSSEL • SUPPLIED WITH WRENCH • ПОСТАВЛЯЕТСЯ С КЛЮЧОМ
 CLÉ INCLUDE • FORNITI CON CHIAVE INCLUSA • 供货时提供扳手

Zubehör
 Accessories
 Accessoires
 Accessori
 Принадлежности
 零件

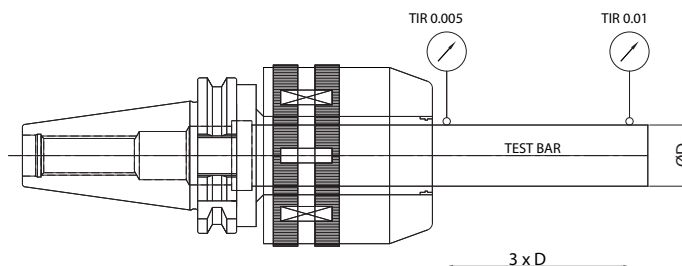

Milling chuck (diameter)	Specification (DIN)	Tolerance (Taper shank)	Run-out (3xD)	Clamping torque
C20	AT3	TC40 (0~+0,003)	0~0,01	980M.m (100 Kgf.m)
C32		TC50 (0~+0,004)		3430M.m (350 Kgf.m)

SPANFUTTER FÜR EINSCHRAUBFRÄSER
MILLING CUTTER ARBORS FOR SCREW-ON TYPE MILLING CUTTERS
ОПРАВКИ ДЛЯ ФРЕЗЕРНЫХ ГОЛОВОК

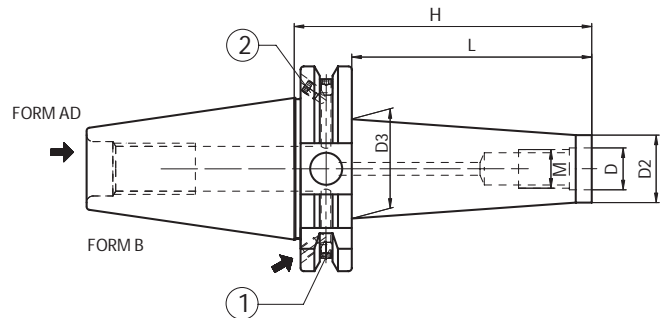

MANDRINS POUR FRAISER A VISSER
MANDRINI PER FRESE CON ATTACCO FILETTATO
螺纹连接型铣刀的铣刀杆



Code N.	Description	ISO	M	D	D2	D3	H	L	G6,3 12000 RPM
217-81320	TC40H55M8 AD+B	40	M8	8,5	13	15	55	36	•
217-81301	TC40H69M8AD+B	40	M8	8,5	13	23	69	50	•
217-81302	TC40H94M8AD+B	40	M8	8,5	13	23	94	75	•
217-81303	TC40H119M8AD+B	40	M8	8,5	13	25	119	100	•
217-81321	TC40H55M10 AD+B	40	M10	10,5	18	20	55	36	•
217-81304	TC40H69M10AD+B	40	M10	10,5	18	23	69	50	•
217-81305	TC40H94M10AD+B	40	M10	10,5	18	28	94	75	•
217-81306	TC40H119M10AD+B	40	M10	10,5	18	32	119	100	•
217-81322	TC40H145M10 AD+B	40	M10	10,5	18	34	145	126	•
217-81323	TC40H55M12 AD+B	40	M12	12,5	21	24	55	36	•
217-81307	TC40H69M12AD+B	40	M12	12,5	21	24	69	50	•
217-81308	TC40H94M12AD+B	40	M12	12,5	21	31	94	75	•
217-81309	TC40H119M12AD+B	40	M12	12,5	21	33	119	100	•
217-81324	TC40H145M12 AD+B	40	M12	12,5	21	38	145	126	•
217-81326	TC40H55M16 AD+B	40	M16	17	29	32	55	36	•
217-81310	TC40H69M16AD+B	40	M16	17	29	34	69	50	•
217-81311	TC40H94M16AD+B	40	M16	17	29	34	94	75	•
217-81312	TC40H119M16AD+B	40	M16	17	29	36	119	100	•
217-81313	TC40H145M16AD+B	40	M16	17	29	40	145	126	•
217-81327	TC40H175M16 AD+B	40	M16	17	29	39	175	156	•
217-81314	TC50H69M12AD+B	50	M12	12,5	21	24	69	50	•
217-81315	TC50H119M12AD+B	50	M12	12,5	21	33	119	100	•
217-81316	TC50H169M12AD+B	50	M12	12,5	21	40	169	150	•
217-81317	TC50H69M16AD+B	50	M16	17	29	34	69	50	•
217-81318	TC50H119M16AD+B	50	M16	17	29	36	119	100	•
217-81319	TC50H169M16AD+B	50	M16	17	29	42.5	169	150	•

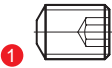

Ersatzteile • Spare parts • Pièces détachées • Componenti • Запасные части • 零件

Tape	Screw	Quantity	Screw	Quantity
				
ISO 40	811-102002 M4X5	2	811-102002 M4X5	2
ISO 50	811-102001 M4X4	2	811-102010 M5X6	2

VERLÄNGERUNG FÜR EINSCHRAUBFRÄSER
EXTENSION FOR SCREW IN TYPE MILLS
КОРПУСА ДЛЯ ФРЕЗЕРНЫХ ГОЛОВОК

RALLONGES POUR FRAISES À VISSER
PROLUNGHE PER FRESE CON ATTACCO FILETTATO
铣刀内部螺丝加长

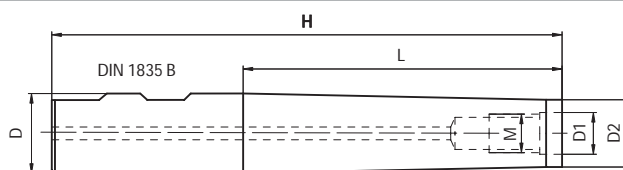

Code N.	Description	D	M	D1	D2	H	L
217-85201	D16H115M8	16	M8	8.5	12.8	115	60
217-85202	D16H160M8	16	M8	8.5	12.8	160	100
217-85203	D20H120M10	20	M10	10.5	17.8	120	60
217-85204	D20H160M10	20	M10	10.5	17.8	160	100
217-85205	D25H160M12	25	M12	12.5	20.8	160	100
217-85206	D32H160M16	32	M16	17	28.8	160	100

VERLÄNGERUNG FÜR EINSCHRAUBFRÄSER
EXTENSION FOR SCREW IN END MILLS
УДЛИНИТЕЛИ ДЛЯ ФРЕЗЕРНЫХ ГОЛОВОК

RALLONGES POUR FRAISES FILETÉE
PROLUNGHE PER FRESE FILETTATE
铣刀内部螺丝加长

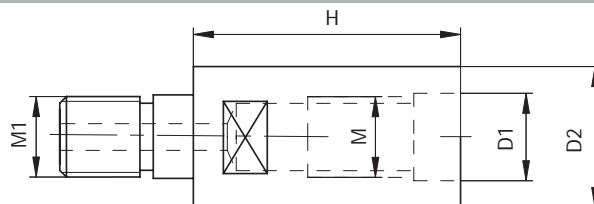

Code N.	Description	M	M1	D1	D2	H
217-85709	M8H30M8	M8	M8	8.5	12.8	30
217-85710	M10H35M10	M10	M10	10.5	17.8	35
217-85711	M12H40M12	M12	M12	12.5	20.8	40
217-85712	M16H40M16	M16	M16	17	28.8	40

ECKFRÄSER
SHOULDER MILLING CUTTERS
ФРЕЗЫ ДЛЯ ОБРАБОТКИ УСТУПОВ

FRAISES À DRESSER
FRESE PER SPALLAMENTI
肩铣刀

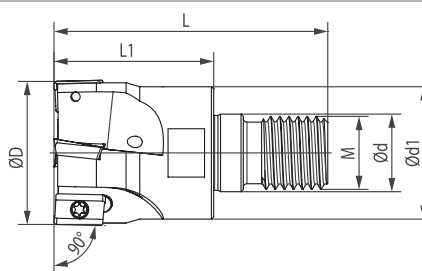

Code N.	Z	D	M	d	d1	L	L1	Insert	Screw	Wrench
454-01023	3	20	M10	10,5	18	50	30	APHT 1003.. APHX 1003.. APKT 1003..	KV25c	816-123002
454-01024	3	25	M12	12,5	21	57	35			
454-01025	4	25	M12	12,5	21	57	35			
454-01026	4	32	M16	17	29	60	35			
454-01027	5	32	M16	17	29	60	35			
454-01028	5	40	M16	17	37	60	35			

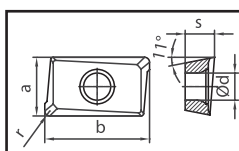

APHT 1003.. APHX 1003.. APKT 1003..	a	b	s	d	r
	6.7	10.8	3.55	2.8	0.5

Mit Luft- und Kühlbohrungen
With Coolant and air holes
с отверстием под охлаждение/воздух
Avec trou pour arrosage et air
Con fori per il passaggio dell'aria e del refrigerante

NC-BOHRFUTTER UNIVERSAL DRILL CHUCKS
УНИВЕРСАЛЬНЫЕ СВЕРЛИЛЬНЫЕ ПАТРОНЫ

MANDRINS UNIVERSELS DE PERCAGE
MANDRINI PORTAPUNTE INTEGRALI
万能钻夹头

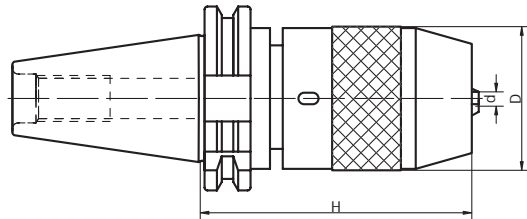

Code N.	Description	ISO	H	D	Clamping capacity	Wrench
252-11200	TC30H110R1-13	30	110	50	1-13	816-111024
252-11211	TC40H100R1-13	40	100	50	1-13	816-111024
252-11212	TC40H115R3-16	40	115	57	3-16	816-111025
252-11213	TC50H100R1-13	50	100	50	1-13	816-111024
252-11214	TC50H105R3-16	50	105	57	3-16	816-111025

RUNDLAUFGENAUIGKEIT 0.04 MM
Zur Erhöhung der Spannkraft werden diese Futter mit Spannschlüssel geliefert.
BEI LINKS LÄUFENDEN BEARBEITUNGEN SIND DIESE FUTTER NICHT ZU BENUTZEN.

RUNOUT ACCURACY 0.04 MM T.I.R.
Supplied with spanner wrench to allow the application of supplementary gripping torque.
DO NOT USE IN REVOLUTION IN COUNTER-CLOCKWISE DIRECTION.

БИЕНИЕ 0,04 MM
Поставляется с ключом для более сильного зажима.
НЕ ВРАЩАТЬ ПРОТИВ ЧАСОВОЙ СРЕЛКИ!

PRECISION DE ROTATION 0.04 MM
Les mandrins sont fournis avec clé de blocage pour augmenter la force de serrage.
NE PAS UTILISER DANS USINAGE AVEC ROTATION A' GAUCHE

PRECISIONE DI ROTAZIONE 0.04 MM
Per incrementare la forza di serraggio i mandrini sono forniti con chiave di bloccaggio.
NON DEVONO ESSERE USATI PER LAVORAZIONI CON ROTAZIONE A SINISTRA.

径向跳动精度 0.04 MM T.I.R.
提供活动扳手，以便施加补充夹紧力。
不得用于逆时针方向旋转。

NC-BOHRFUTTER FÜR RECHTS-UND LINKSLAUF
NC DRILL CHUCKS FOR LEFT AND RIGHT ROTATION
СВЕРЛИЛЬНЫЕ ПАТРОНЫ С ВРАЩЕНИЕМ ПО- И ПРОТИВ ЧАСОВОЙ СРЕЛКИ ДЛЯ СТАНКОВ С ЧПУ

MANDRIN DE PERCAGE CNC POUR ROTATION GAUCHE-DROITE
MANDRINI PORTAPUNTE INTEGRALI PER ROTAZIONE DESTRA E SINISTRA
左右旋转 NC 钻夹头

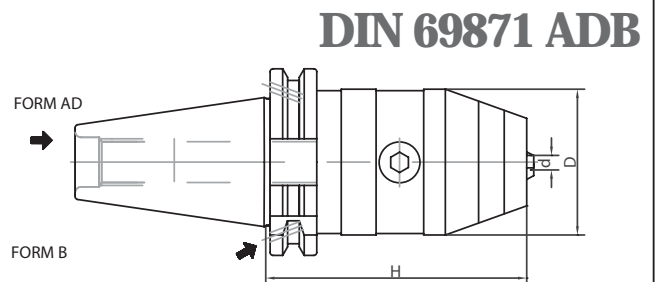

Code N.	Description	ISO	H	D	Clamping capacity	Wrench
252-11300	TC30H120R1-13X	30	120	50	1-13	816-152001
252-11301	TC40H90R1-13X	40	90	50	1-13	816-152001
252-11302	TC40H95R3-16X	40	95	57	3-16	816-152001
252-11303	TC50H90R1-13X	50	90	50	1-13	816-152001
252-11304	TC50H95R3-16X	50	95	57	3-16	816-152001

RUNDLAUFGENAUIGKEIT 0.03 MM
Sowohl für rechts- als auch links laufende Bearbeitungen geeignet,
mit Höchstgeschwindigkeit von 7000 u/min.

RUNOUT ACCURACY 0.03 MM T.I.R.
Suitable for right and left rotation up to 7000 rpm.

БИЕНИЕ 0,03 MM
Можно вращать по- и против часовой стрелки
со скоростью до 7000 об/мин.

PRECISION DE ROTATION 0.03 MM
Utilisables pour rotation droite et gauche,
avec maximale vélocité 7000 rpm

PRECISIONE DI ROTAZIONE 0.03 MM.
Adatti per rotazione sia destra che sinistra,
con velocità max di 7000 g/min.

径向跳动精度 0.03 MM T.I.R.
适用于最高转速达 7000 转/分钟的左右旋转

ROHLINGE MIT WEICHEM SCHAFT
BLANK TOOLHOLDER WITH SOFT SHANK
ЗАГОТОВКИ ДЛЯ ОПРАВОК НЕЗАКАЛЕННЫЕ

BARRES D'ALEPAGE SEMI-FINIES
MANDRINI SEMILAVORATI A STELO TENERO
带软柄的切断刀柄

DIN 69871 A

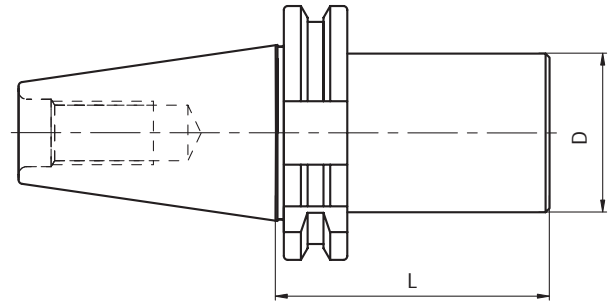

Code N.	Description	ISO	D	L
217-41204	TC40H160D40.5SM	40	40.5	160
217-41205	TC40H160D63.5SM	40	63.5	160
217-41206	TC40H250D63.5SM	40	63.5	250
217-41207	TC50H160D80SM	50	80	160
217-41208	TC50H200D80SM	50	80	200
217-41209	TC50H300D80SM	50	80	300

GEWINDESCHNEID-SCHNELLWECHSELFUTTER
MIT LÄNGENAUSGLEICH
TENSION AND COMPRESSION TAPPING HEAD
РЕЗЬБОНАРЕЗНЫЕ ПАТРОНЫ С КОМПЕНСАЦИЕЙ

MANDRINS DE TARAUDAGE A CHANGEMENT
RAPIDE A DOUBLE USAGE
MASCHIATORI A DOPPIA COMPENSAZIONE
张力和压缩丝攻头

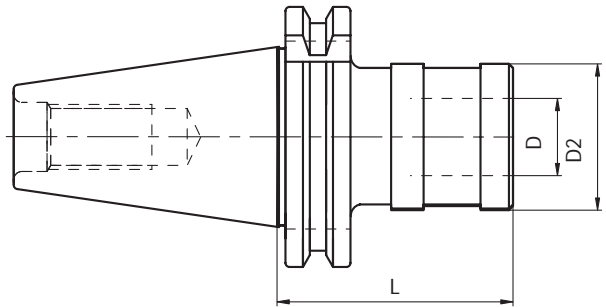

Code N.	Description	ISO	SIZE	Top range	PRESS.	EXT.	D	D2	L
M3008	TC30H60GR1.DC	30	1	M3-M12	9	9	19	38	60
M3010	TC40H60GR1.DC	40	1	M3-M12	9	9	19	38	60
M3110	TC40H92GR2.DC	40	2	M6-M20	15	15	31	53	92
M3210	TC40H138GR3.DC	40	3	M14-M33	24	24	48	78	138
M3030	TC50H62GR1.DC	50	1	M3-M12	9	9	19	38	62
M3130	TC50H83GR2.DC	50	2	M6-M20	15	15	31	53	83
M3230	TC50H133GR3.DC	50	3	M14-M33	24	24	48	78	133

GEWINDESCHNEID-SCHNELLWECHSELFUTTER
OHNE LÄNGENAUSGLEICH
SOLID TAPPING HEAD
РЕЗЬБОНАРЕЗНЫЕ ПАТРОНЫ БЕЗ КОМПЕНСАЦИИ

MANDRINS DE TARAUDAGE A CHANGEMENT
RAPIDE SANS COMPENSATION
MASCHIATORI RIGIDI SENZA COMPENSAZIONE
固定攻丝头

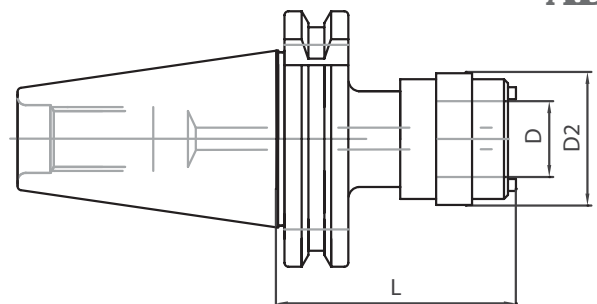

Code N.	Description	ISO	SIZE	Top range	D	D2	L
M5020	TC40H59GR1.SC	40	1	M3-M12	19	33	59
M5040	TC40H82GR2.SC	40	2	M6-M20	31	50	82

Zubehör
Accessories
Accessoires
Accessori
Принадлежности
零件



SONDERWERKZEUGHALTER
SPECIAL TOOLS
СПЕЦИАЛЬНЫЕ ИНСТРУМЕНТЫ

PORTE-OUTILS SPÉCIAUX
PRODOTTI SPECIALI
特殊工具



The logo for KAMATEK features the company name in a bold, black, sans-serif font. The letters 'K' and 'K' at the beginning and end of the name are stylized with red and yellow geometric shapes. The background of the entire page is a light blue color with a faint, repeating pattern of interlocking metal mesh or a grid of lines.

KAMATEK

**JIS B 6339
(MAS 403BT A-AD/B-AD)**



TECHNISCHE DATEN DER STEILKEGELWERKZEUGE
TAPER SHANKS DATA SHEET
КОНСТРУКТИВНЫЕ РАЗМЕРЫ

DONNEES TECHNIQUES QUEUE D'OUTILS
DATI TECNICI CONI D'ATTACCO
锥柄数据表

MAS 403/BT A

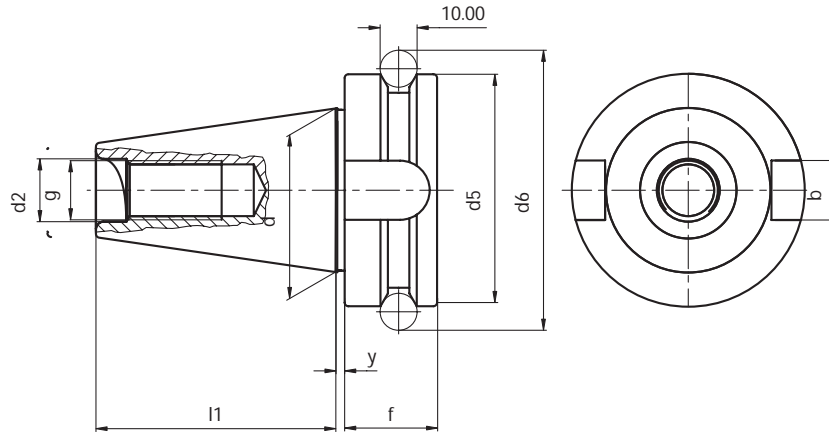

BT	d	l1	d2	g	y	d5	f	d6	b
30	31,75	48,4	12,5	M12	2	46	20	56,144	16,1
40	44,45	65,4	17	M16	2	63	25	75,68	16,1
50	69,85	101,8	25	M24	3	100	35	110,02	25,7

TECHNISCHE DATEN DER STEILKEGELWERKZEUGE
TAPER SHANKS DATA SHEET
КОНСТРУКТИВНЫЕ РАЗМЕРЫ

DONNEES TECHNIQUES QUEUE D'OUTILS
DATI TECNICI CONI D'ATTACCO
锥柄数据表

MAS 403/BT AD/B

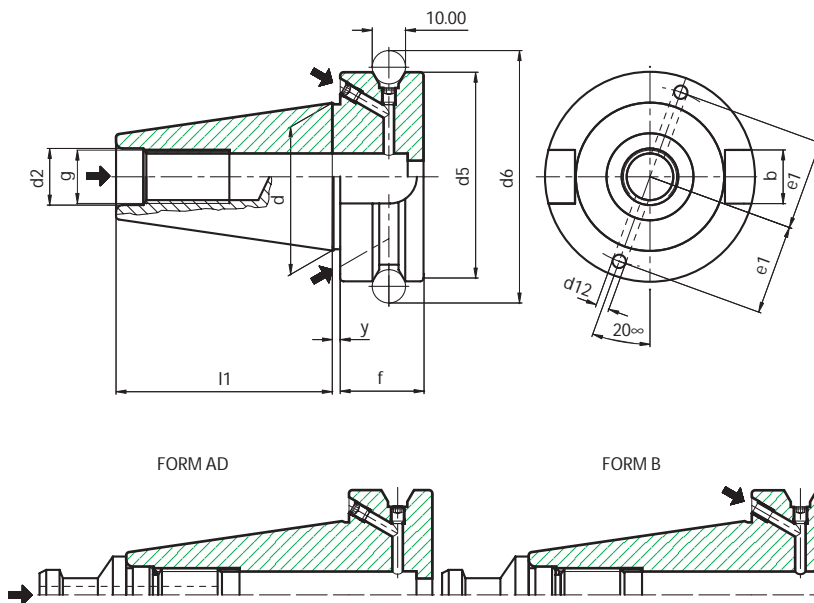

BT	d	l1	d2	g	y	d5	f	d6	d12	e1	b
40	44,45	65,4	17	M16	2	63	25	75,68	4	27	16,1
50	69,85	101,8	25	M24	3	100	35	110,02	5	42	25,7

Das Kühlmittel geht durch die Löcher am Bund (B) oder, wenn die Löcher mit den Schrauben geschlossen werden, zentral durch Aufnahme (AD).
For coolant through V-flange bores (B) or center of toolholders (AD). For central coolant, the V-flange channels are closed by socket screws.

Для подачи СОЖ через отверстия во фланце (форма B) или через центральное отверстие (форма AD). Для подачи СОЖ через центральное отверстие боковые должны быть закрыты винтами.

Le lubrifiant passe par les trous de la bride (B) ou, si on ferme les trous avec des vis, par le centre du mandrin (AD).

Il lubrificante passa dai fori sulla flangia (B) oppure, chiudendo i fori con le apposite viti, dal centro del mandrino (AD).

冷却剂需通过V型法兰孔 (B) 或刀柄 (AD)。对于中央冷却剂, V型法兰通道是由凹头螺丝拧紧的。



Alle Kintek-Steilkegelaufnahmen werden nach den DIN-Normen angefertigt.

KEGELSCHAFTTOLERANZ

In Klasse AT3 angefertigt.

ISO	L	dA-dB	AT3
30	42	12.250	+0.002
40	59	17.208	+0.003
50	92	26.833	+0.004

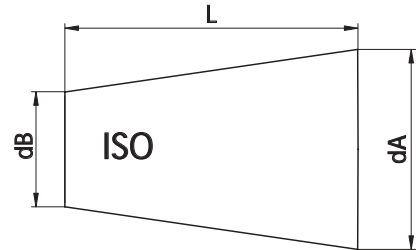

SPANNZANGENAUFNAHME RUNDLAUFGENAUIGKEIT

Die DIN 6391- Norm schreibt eine Rundlaufgenauigkeit zwischen Aussenkegel und Innenkegel / Spannzangensitz vom 0,016 vor. Unsere Spannzangenfutter weisen einen Rundlauffehler zwischen ISO-Kegelaufnahme und Spannzangensitz, der zwischen 0,003 und 0,010 mm liegt.

AUFSTECKFRÄSDORNE - RUNDLAUFGENAUIGKEIT

Kintek- Aufsteckfräsdorne entsprechen der DIN 6358- Norm, die einen höchsten Rundlauffehler zwischen ISO 30- und ISO40- Kegel und den Durchmessern 16-22-27-32-40 vom 0,01 vorsieht. Der mögliche höchste Rundlauffehler für ISO 50 ist 0,015 mm.

WELDON AUFSTECKFRÄSDORNE - RUNDLAUFGENAUIGKEIT

Nach der DIN 6359-1-Norm müssen die Weldon- Aufsteckfräsdorne die folgenden Forderungen aufweisen:
Bohrung: Toleranz H5
Rundlaufgenauigkeit: höchster möglicher Rundlauffehler zwischen Kegel und Weldonsitz < 0,01 (für ISO 40)
Die vorgeschriebene Toleranz der Bohrung und eine durchschnittliche Rundlaufgenauigkeit von 0,005 sind erreicht.

WUCHTUNG

Die meisten Werkzeughalter dieser Gruppe sind in Klasse G6,3 auf 8.000 U/Min -1 vorgewuchtet oder auf 12.000 U/Min -1 gewuchtet.
Neben der Übersichtstabelle der Produkte wird die Wuchtgüte angegeben.

KONSTRUKTIONS DATEN

- aus legiertem Einsatzstahl angefertigt
- in der Einsatzhärte tiefe von 0,4 - 0,5 mm
- gehärtet, angelassen
- Härte HRC58 +-2, Festigkeit 800-1000 N/mm²
- brüniert
- inneres, äußeres Schleifen und am Gewinde der Spannzangenmutter

WUCHTUNG FÜR HÖHERE DREHZAHLEN

Die Steilkegelaufnahmen der neuen Linie werden in Klasse G2,5 auf 25.000 U/Min -1 gewuchtet.

KONSTRUKTIONS DATEN

- aus legiertem Einsatzstahl angefertigt
- in der Einsatzhärte tiefe von 0,4 - 0,5 mm
- gehärtet, angelassen
- Härte HRC 58 +- 2, Festigkeit 800-1000 N/mm²
- brüniert
- inneres, äußeres Schleifen des Kegels
- Schleifen der Vorderseite und am Gewinde der Spannzangenmutter
- 100% durch zertifizierte Meßinstrumente geprüft und mit Wuchtungsprotokoll geliefert



ALL KINTEK TOOLHOLDERS ARE MANUFACTURED ACCORDING TO DIN NORM.

CONE'S TOLERANCE

ACCORDING TO THE CLASS AT3.

ISO	L	dA-dB	AT3
30	42	12.250	+0.002
40	59	17.208	+0.003
50	92	26.833	+0.004

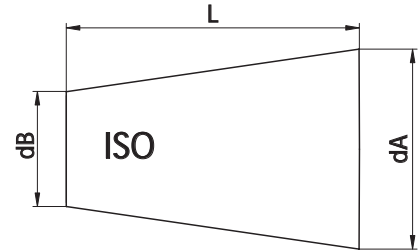

COLLET CHUCK'S RUNOUT ACCURACY

The norm DIN6391 permits a runout error between external cone and internal cone / collet seat of 0.016. Our production has a runout accuracy which is guaranteed to be within 0,003 / 0,010 m at the tool seat.

SHELL END MILL ADAPTOR'S RUNOUT ACCURACY

Our shell end mill adaptors meet the requirements of the norm DIN6358, which prescribes for diameters 16-22-27-32-40 a runout accuracy of: 0, 01 for SK 30/40 0,015 for SK 50.

WELDON END MILL HOLDER'S RUNOUT ACCURACY

According to the norm DIN6359-1 Weldon end mill holders have to meet the following requirements:

Bore: H5 tolerance

Runout accuracy: < 0.01 (for SK 40)

Our end mill adaptors ensure the prescribed holes' tolerance and have a runout accuracy which is normally 0.005

BALANCING

The major part of toolholders of this category can run up to 8000 rpm grade G 6,3 or 12000 rpm. Besides the descriptive and dimensional table of products, you can find the additive balancing grade.

CONSTRUCTIVE FEATURES

- Manufactured with Casehardening Steel.
- Casehardened with depth 0,4 - 0,5 mm
- Hardened-Tempered
- Hardness HRC 58+-2, Strength 800-1000 N/mm2
- Black oxided
- Internal and external grinding finished.

NEW HIGH-SPEED BALANCING TOOLHOLDERS

The new high-speed toolholders are balanced in the Grade G 2,5 at 25000 rpm.

CONSTRUCTIVE FEATURES FOR HIGH-SPEED TOOLHOLDERS

- Manufactured with casehardening Steel.
- Casehardened with depth 0,4 - 0,5 mm
- Hardened-Tempered
- Hardness HRC 58+-2, Strength 800-1000 N/mm2
- Black oxided
- Internal and external grinding finish of the cone
- Grinding finish on the front side and on the thread of collet nuts.
- Tested 100% with certified measuring instruments and supplied with balancing certificate



Все оправки KINTEK произведены согласно стандарту DIN.

ТОЧНОСТЬ КОНУСА

Соответствует классу AT3.

ISO	L	dA-dB	AT3
30	42	12.250	+0.002
40	59	17.208	+0.003
50	92	26.833	+0.004

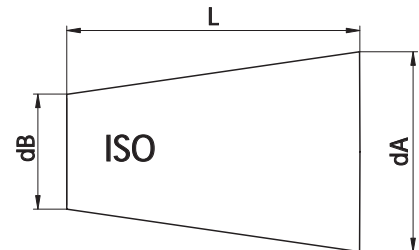

БИЕНИЕ ЦАНГОВЫХ ПАТРОНОВ

В соответствии с нормами DIN6391, допустимое биение конуса оправки относительно конического отверстия под цангу составляет 0,016 мм. Гарантированная точность биения отверстия под инструмент - 0,003 мм/0,010 мм.

БИЕНИЕ ОПРАВОК ДЛЯ НАСАДНЫХ ФРЕЗ

Патроны изготовлены в соответствии с требованиями DIN 6358, согласно которым биение для диаметров 16-22-27-32-40 составляет 0,01 мм для SK 30/40 и 0,015 мм для SK 50.

БИЕНИЕ ПАТРОНОВ С КРЕПЛЕНИЕМ WELDON

Оправки соответствуют следующим требованиям DIN 6359-1:

Точность отверстия: H5

Биение: < 0,01 (для SK 40)

Оправки Kintek изготовлены с гарантированной точностью отверстий и биением 0,005 мм.

БАЛАНСИРОВКА

Оправки данной категории предварительно сбалансированы по классу G6,3 при 8000 об/мин или 12000 об/мин.

КОНСТРУКТИВНЫЕ ОСОБЕННОСТИ

- Изготовлены из стали с последующей цементацией
- Цементация на глубину 0,4 - 0,5 мм
- Оправки подвергнуты закалке и отпуску
- Твердость 58+/-2 HRC, прочность 800-1000 Н/мм²
- Защитно-декоративное покрытие черного цвета
- Шлифованные внутренняя и внешняя поверхности

НОВЫЕ ВЫСОКОСКОРОСТНЫЕ СБАЛАНСИРОВАННЫЕ ОПРАВКИ

Новые высокоскоростные оправки сбалансированы до класса G 2,5 при 25000 об/мин.

КОНСТРУКТИВНЫЕ ОСОБЕННОСТИ ВЫСОКОСКОРОСТНЫХ ОПРАВОК

- Изготовлены из стали с последующей цементацией
- Цементация на глубину 0,4 - 0,5 мм
- Оправки подвергнуты закалке и отпуску
- Твердость 58+/-2 HRC, прочность 800-1000 Н/мм²
- Защитно-декоративное покрытие черного цвета
- Шлифованные внутренняя и внешняя поверхности
- Шлифованный торец и резьба под гайку в цанговых патронах
- Каждая оправка испытана и поставляется с сертификатом о балансировке



Tous les mandrins porte-outils KINTEK sont produits suivant les spécifications DIN

TOLLERANCE DU CONE

EN CLASSE AT3.

ISO	L	dA-dB	AT3
30	42	12.250	+0.002
40	59	17.208	+0.003
50	92	26.833	+0.004

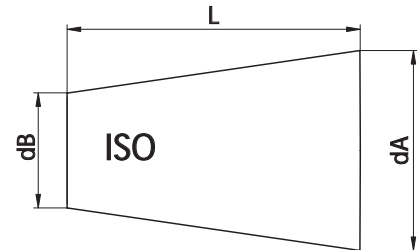

COAXIALITE' PORTE-PINCE

La norme DIN6391 admet une erreur maximum de 0.016 soit pour les porte-pinces DIN6499 soit pour DIN6388. Dans notre production l'écart d'excentricité maximum entre cône ISO et logement de la pince est compris entre: 0,003 et 0,0010 mm.

COAXIALITE' PORTE-FRAISES FIXES ET COMBINES

Les porte-fraises fixes et combinés de notre production suivent la spécification de la norme DIN6358, qui prévoit pour les diamètres 16-22-27-32-40 une concentricité de 0,01 pour ISO 30 et ISO 40, 0,015 pour ISO 50

COAXIALITE' PORTE-FRAISES WELDON

Suivant les spécifications DIN 6359-1 les porte-fraises WELDON doivent suivre les conditions suivantes:

Trou : tolérance H5

Coaxialité: écart maximum toléré entre cône et logement du Weldon <0.01 (pour ISO 40).

Nous assurons la tolérance prévue sur le trou et une coaxialité en moyenne de 0.005.

EQUILIBRAGE

La plupart des porte-outils sont pré-équilibrés en classe G 6,3 8000 Tr/Min -1. ou équilibrés à 12000 Tr/Min-1. A côté du tableau de description et dimensions des produits il y a l'indication de la valeur d'équilibrage additionnel.

ELEMENTS DE CONSTRUCTION

- Produits en acier cémenté allié.
- Cémentés avec une profondeur 0,4 - 0,5 mm
- Trempés - Revenus
- Dureté HRC 58 +/- 2 résistance 800-1000 N/ mm²
- Brunis
- Rectification du cône intérieur, extérieur et dans le filetage des écrous qui serrent la pince.

EQUILIBRAGE MANDRINS POUR HAUTE VITESSE

Les mandrins de la nouvelle ligne à haute vitesse sont équilibrés en classe G 2,5 à 25000 Tr/mn-1.

ELEMENTS DE CONSTRUCTION POUR MANDRINS HAUTE VITESSE

- Produits en acier cémenté allié.
- Cémentés avec une profondeur 0,4 - 0,5 mm
- Trempés - Revenus
- Dureté HRC 58 +/- 2 résistance 800-1000 N/ mm²
- Brunis
- Finition de rectification intérieure, extérieure et du cône
- Rectification du cône intérieur et dans le filetage des écrous qui serrent la pince.
- Contrôlés à 100 % avec des instruments de mesure certifiés et livrés avec un certificat d'équilibrage.



TUTTI I MANDRINI PORTAUTENSILI KINTEK VENGONO PRODOTTI SECONDO LE NORMATIVE DIN

TOLLERANZA DEL CONO

PRODOTTI IN CLASSE AT3.

ISO	L	dA-dB	AT3
30	42	12.250	+0.002
40	59	17.208	+0.003
50	92	26.833	+0.004

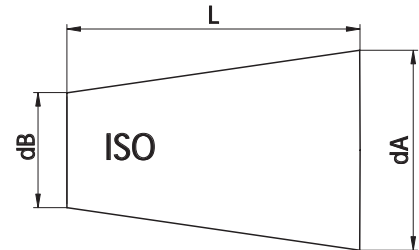

COASSIALITÀ PORTAPINZE

La norma DIN6391 ammette un'errore massimo di 0.016 sia per i portapinze DIN6499 che per DIN6388.

La nostra produzione normalmente presenta uno scostamento massimo di eccentricità tra cono ISO e sede pinza compreso tra i 0,003 e 0,010 mm.

COASSIALITÀ PORTAFRESE FISSI E COMBINATI

I portafrese fissi e combinati di nostra produzione rispondono ai criteri prescritti dalla norma DIN6358, la quale prevede un errore massimo di coassialità tra cono ISO 30 e ISO 40 ed i diametri 16-22-27-32-40, di 0,01.

Mentre per ISO 50 è ammesso un errore massimo di 0,015 mm.

COASSIALITÀ PORTAFRESE WELDON

Rispettando la normativa DIN 6359-1 i portafrese WELDON devono rispondere ai seguenti requisiti:

foro: tolleranza H5

coassialità: scostamento massimo consentito tra cono e sede Weldon <0.01 (per ISO 40)

Garantiamo la tolleranza prescritta sul foro e un valore di coassialità mediamente di 0.005.

EQUILIBRATURA

La maggior parte dei portautensili presenti in questa categoria sono prebilanciati in classe G 6,3 8000 rpm min⁻¹. o bilanciati a 12000 giri rpm min⁻¹.

A fianco della tabella descrittiva e dimensionale dei prodotti viene elencato il grado di equilibratura aggiuntiva.

DATI COSTRUTTIVI

- Costruiti in acciaio da cementazione legato.
- Cementati con profondità 0,4 - 0,5 mm
- Temprati-rinvenuti
- Durezza HRC 58 +- 2 resistenza 800-1000 N/ mm2
- Bruniti
- Finitura di rettifica interna, esterna e nelle filettature delle ghiera chiudipinza

EQUILIBRATURA MANDRINI PER ALTE VELOCITÀ

I mandrini presenti nella linea nuova ad alta velocità vengono bilanciati in classe G 2,5 a 25000 rpm min⁻¹.

DATI COSTRUTTIVI PER MANDRINI PER ALTE VELOCITÀ

- Costruiti in acciaio da cementazione legato.
- Cementati con profondità 0,4 - 0,5 mm
- Temprati-rinvenuti
- Durezza HRC 58 +- 2 resistenza 800-1000 N/ mm2
- Bruniti
- Finitura di rettifica interna, esterna del cono
- Rettifica parte anteriore e nelle filettature delle ghiera chiudipinza
- Collaudati 100% con strumenti di misura certificati e forniti con certificato di bilanciatura.



所有 KINTEK 刀柄均根据 DIN 标准来制造。

锥体的误差

根据 AT3 级别

ISO	L	dA-dB	AT3
30	42	12.250	+0.002
40	59	17.208	+0.003
50	92	26.833	+0.004

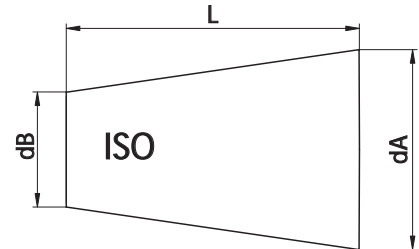

弹簧夹头的径向跳动精度

DIN6391 标准允许在外部锥体与内部锥体/夹头座之间的径向跳动误差为 0.016。我公司生产可保证在工具底座处径向跳动精度为 0,003 / 0,010 米之间。

平面铣接头的径向跳动精度

我公司的平面铣接头满足 DIN6358 标准要求，该标准描述了直径为 16-22-27-32-40 的径向跳动精度，对于 SK 30/40 为 0,01，对于 SK 50 为 0,015。

威尔登式端铣夹具的径向跳动精度

根据 DIN6359-1 标准规定，威尔登式端铣夹具必须要达到下列要求：

孔：H5 误差

径向跳动精度：< 0.01 (对于 SK 40)

我公司的平面铣接头确保可达到规定的孔的误差，通常的径向跳动精度为 0.005。

平衡

这种类型的刀柄的主要部分最高转速可达到 G 6,3 级的 8000 转/分钟或 12000 转/分钟。除了产品的描述性和尺寸表格以外，还可找到平衡等级。

结构特点

- 用表面硬化钢材制造。
- 硬化深度达 0,4 - 0,5 毫米。
- 经过硬化及回火处理。
- 硬度达 HRC 58+-2，强度达 800-1000 N / 平方毫米。
- 黑色氧化。
- 内部及外部表面打磨处理。

新型高速平衡刀柄

新型高速平衡刀柄以 G 2.5 级，25000 转/分钟来平衡。

高速刀柄的结构特点

- 用表面硬化钢材制造。
- 硬化深度达 0,4 - 0,5 毫米。
- 经过硬化及回火处理。
- 硬度达 HRC 58+-2，强度达 800-1000 N / 平方毫米。
- 黑色氧化。
- 锥体内部及外部表面打磨处理。
- 夹头螺母螺纹正面和上面进行打磨处理。
- 100% 使用经认证的测量仪器检测，供货时提供平衡检验证书。

ZYLINDERSCHAFTAUFNAHME WELDON
END MILL HOLDERS WELDON
ОПРАВКИ С КРЕПЛЕНИЕМ WELDON

MANDRINS POUR OUTILS TYPE WELDON
MANDRINI PORTAFRESE TIPO WELDON
威尔登式端铣夹具

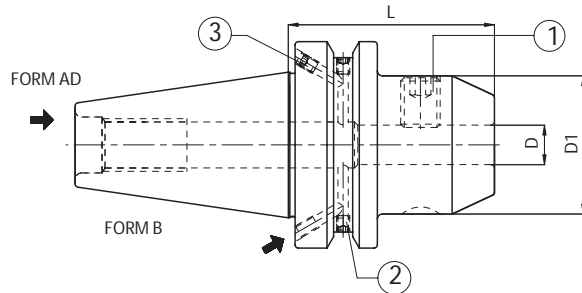

DIN 1835 B



Code N.	Description	ISO	D	L	D1	G2,5 25000 RPM
213-91401	BT40H50WE06 AD+B	40	6	50	25	•
213-91402	BT40H50WE08 AD+B	40	8	50	28	•
213-91403	BT40H63WE10 AD+B	40	10	63	35	•
213-91404	BT40H63WE12 AD+B	40	12	63	42	•
213-91405	BT40H63WE14 AD+B	40	14	63	44	•
213-91406	BT40H63WE16 AD+B	40	16	63	48	•
213-91407	BT40H63WE18 AD+B	40	18	63	50	•
213-91408	BT40H63WE20 AD+B	40	20	63	52	•
213-91409	BT40H90WE25 AD+B	40	25	90	65	•
213-91410	BT40H100WE32 AD+B	40	32	100	72	•
213-91412	BT50H63WE06 AD+B	50	6	63	25	•
213-91413	BT50H63WE08 AD+B	50	8	63	28	•
213-91414	BT50H70WE10 AD+B	50	10	70	35	•
213-91415	BT50H80WE12 AD+B	50	12	80	42	•
213-91416	BT50H80WE14 AD+B	50	14	80	44	•
213-91417	BT50H80WE16 AD+B	50	16	80	48	•
213-91418	BT50H80WE18 AD+B	50	18	80	50	•
213-91419	BT50H80WE20 AD+B	50	20	80	52	•
213-91420	BT50H100WE25 AD+B	50	25	100	65	•
213-91421	BT50H105WE32 AD+B	50	32	105	72	•

High balanced

Ersatzteile • Spare parts • Pièces détachées • Componenti • Запасные части • 零件

Type	Screw	Quantity	Screw	Quantity	D	Locking screw	Quantity
							
ISO 40	811-102002 M4X5	2	811-102002 M4X5	2	6	811-106001	1
ISO 50	811-102002 M4X5	2	811-102010 M5X6	2	8	811-106002	1
					10	811-106004	1
					12,14	811-106005	1
					16,18	811-106006	1
					20	811-106007	1
					25	811-106008	2
					32	811-106009	2

ZYLINDERSCHAFTAUFNAHME WELDON-LANG
END MILL HOLDERS WELDON-LONG PROJECTION TYPE
ОПРАВКИ С КРЕПЛЕНИЕМ WELDON. УДЛИНЕННОЕ ИСПОЛНЕНИЕ

MANDRINS POUR OUTILS TYPE WELDON-SERIE LONGUE
MANDRINI PORTAFRESE TIPO WELDON-SERIE LUNGA
威尔登式端铣夹具-加长凸点式

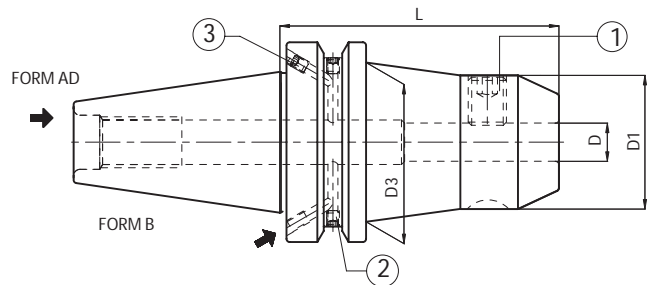

DIN 1835 B



Code N.	Description	ISO	D	L	D1	D3	G2,5 25000 RPM	
H 100	213-91424	BT40H100WE06 AD+B	40	6	100	25	35	•
	213-91425	BT40H100WE08 AD+B	40	8	100	28	38	•
	213-91426	BT40H100WE10 AD+B	40	10	100	35	40	•
	213-91427	BT40H100WE12 AD+B	40	12	100	42	-	•
	213-91428	BT40H100WE14 AD+B	40	14	100	44	-	•
	213-91429	BT40H100WE16 AD+B	40	16	100	48	-	•
	213-91430	BT40H100WE18 AD+B	40	18	100	50	-	•
	213-91431	BT40H100WE20 AD+B	40	20	100	52	-	•
	213-91432	BT50H100WE06 AD+B	50	6	100	25	35	•
	213-91433	BT50H100WE08 AD+B	50	8	100	28	38	•
	213-91434	BT50H100WE10 AD+B	50	10	100	35	42	•
	213-91435	BT50H100WE12 AD+B	50	12	100	42	48	•
	213-91436	BT50H100WE14 AD+B	50	14	100	44	50	•
	213-91437	BT50H100WE16 AD+B	50	16	100	48	54	•
	213-91438	BT50H100WE18 AD+B	50	18	100	50	62	•
	213-91439	BT50H100WE20 AD+B	50	20	100	52	66	•

High balanced

Ersatzteile • Spare parts • Pièces détachées • Componenti • Запасные части • 零件

Type	Screw	Quantity	Screw	Quantity	D	Locking screw	Quantity
							
ISO 40	811-102002 M4X5	2	811-102002 M4X5	2	6	811-106001	1
ISO 50	811-102002 M4X5	2	811-102010 M5X6	2	8	811-106002	1
					10	811-106004	1
					12,14	811-106005	1
					16,18	811-106006	1
					20	811-106007	1
					25	811-106008	2
					32	811-106009	2

ZYLINDERSCHAFTAUFNAHME WELDON
END MILL HOLDERS WELDON
ОПРАВКИ С КРЕПЛЕНИЕМ WELDON

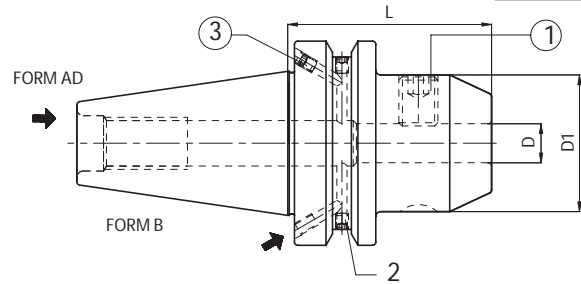

MANDRINS POUR OUTILS TYPE WELDON
MANDRINI PORTAFRESE TIPO WELDON
威尔登式端铣夹具

DIN 1835 B



Code N.	Description	ISO	D	L	D1	G6,3 12000 RPM
*263-11501	BT30H50WE06	30	6	50	25	•
*263-11502	BT30H50WE08	30	8	50	28	•
*263-11503	BT30H50WE10	30	10	50	35	•
*263-11504	BT30H55WE12	30	12	55	42	•
*263-11505	BT30H63WE16	30	16	63	48	•
*263-11506	BT30H70WE20	30	20	70	52	•
213-11413	BT40H50WE06 AD+B	40	6	50	25	•
213-11414	BT40H50WE08 AD+B	40	8	50	28	•
213-11415	BT40H63WE10 AD+B	40	10	63	35	•
213-11416	BT40H63WE12 AD+B	40	12	63	42	•
213-11417	BT40H63WE14 AD+B	40	14	63	44	•
213-11418	BT40H63WE16 AD+B	40	16	63	48	•
213-11419	BT40H63WE18 AD+B	40	18	63	50	•
213-11420	BT40H63WE20 AD+B	40	20	63	52	•
213-11421	BT40H90WE25 AD+B	40	25	90	65	•
213-11422	BT40H100WE32 AD+B	40	32	100	72	•
213-11465	BT40H105WE40 AD+B	40	40	105	80	•
213-11423	BT50H63WE06 AD+B	50	6	63	25	•
213-11424	BT50H63WE08 AD+B	50	8	63	28	•
213-11425	BT50H70WE10 AD+B	50	10	70	35	•
213-11426	BT50H80WE12 AD+B	50	12	80	42	•
213-11427	BT50H80WE14 AD+B	50	14	80	44	•
213-11428	BT50H80WE16 AD+B	50	16	80	48	•
213-11429	BT50H80WE18 AD+B	50	18	80	50	•
213-11430	BT50H80WE20 AD+B	50	20	80	52	•
213-11431	BT50H100WE25 AD+B	50	25	100	65	•
213-11432	BT50H105WE32 AD+B	50	32	105	72	•
213-11433	BT50H120WE40 AD+B	50	40	120	80	•
263-11425	BT50H125WE50 AD+B	50	50	125	100	•

Ersatzteile • Spare parts • Pièces détachées • Componenti • Запасные части • 零件

Type	Screw	Quantity	Screw	Quantity	D	Locking screw	Quantity
							
ISO 40	811-102002 M4X5	2	811-102002 M4X5	2	6	811-106001	1
ISO 50	811-102002 M4X4	2	811-102010 M5X6	2	8	811-106002	1
					10	811-106004	1
					12,14	811-106005	1
					16,18	811-106006	1
					20	811-106007	1
					25	811-106008	2
					32	811-106009	2
					40	811-106009	2
					50	811-106011	2

* Ausführung Form AD
* Execution form AD
* Forme AD
* Forma AD
* Исполнение AD
* 执行形式 AD

ZYLINDERSCHAFTAUFNAHME WELDON-LANG
 END MILL HOLDERS WELDON-LONG PROJECTION TYPE
 ОПРАВКИ С КРЕПЛЕНИЕМ WELDON. УДЛИНЕННОЕ ИСПОЛНЕНИЕ.

MANDRINS POUR OUTILS TYPE WELDON-SERIE LONGUE
 MANDRINI PORTAFRESE TIPO WELDON-SERIE LUNGA
 威尔登式端铣夹具-加长凸点式

DIN 1835 B

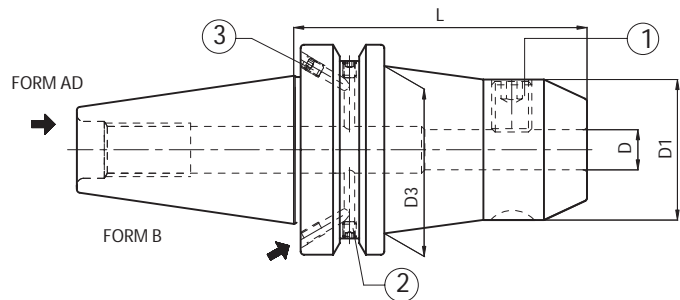

Code N.	Description	ISO	D	L	D1	D3	G6,3 12000 RPM	G6,3 8000 RPM	
H 100	213-11434	BT40H100WE06 AD+B	40	6	100	25	35	•	
	213-11435	BT40H100WE08 AD+B	40	8	100	28	38	•	
	213-11436	BT40H100WE10 AD+B	40	10	100	35	40	•	
	213-11437	BT40H100WE12 AD+B	40	12	100	42	-	•	
	213-11438	BT40H100WE14 AD+B	40	14	100	44	-	•	
	213-11439	BT40H100WE16 AD+B	40	16	100	48	-	•	
	213-11440	BT40H100WE18 AD+B	40	18	100	50	-	•	
	213-11441	BT40H100WE20 AD+B	40	20	100	52	-	•	
	213-11448	BT50H100WE06 AD+B	50	6	100	25	35		•
	213-11449	BT50H100WE08 AD+B	50	8	100	28	38		•
	213-11450	BT50H100WE10 AD+B	50	10	100	35	42		•
	213-11451	BT50H100WE12 AD+B	50	12	100	42	48		•
	213-11452	BT50H100WE14 AD+B	50	14	100	44	50		•
	213-11453	BT50H100WE16 AD+B	50	16	100	48	54		•
	213-11454	BT50H100WE18 AD+B	50	18	100	50	62		•
213-11455	BT50H100WE20 AD+B	50	20	100	52	66		•	
H 160	213-11442	BT40H160WE06 AD+B	40	6	160	25	35	•	
	213-11443	BT40H160WE08 AD+B	40	8	160	28	38	•	
	213-11444	BT40H160WE10 AD+B	40	10	160	35	40	•	
	213-11445	BT40H160WE12 AD+B	40	12	160	42	-	•	
	213-11466	BT40H160WE14 AD+B	40	14	160	44	-	•	
	213-11446	BT40H160WE16 AD+B	40	16	160	48	-	•	
	213-11467	BT40H160WE18 AD+B	40	18	160	50	-	•	
	213-11447	BT40H160WE20 AD+B	40	20	160	52	-	•	
	213-11468	BT40H160WE25 AD+B	40	25	160	65	-	•	
	213-11469	BT40H160WE32 AD+B	40	32	160	72	-	•	
	213-11457	BT50H160WE06 AD+B	50	6	160	25	42		•
	213-11458	BT50H160WE08 AD+B	50	8	160	28	45		•
	213-11459	BT50H160WE10 AD+B	50	10	160	35	49		•
	213-11460	BT50H160WE12 AD+B	50	12	160	42	55		•
	213-11470	BT50H160WE14 AD+B	50	14	160	44	57		•
	213-11461	BT50H160WE16 AD+B	50	16	160	48	60		•
	213-11471	BT50H160WE18 AD+B	50	18	160	50	63		•
	213-11462	BT50H160WE20 AD+B	50	20	160	52	69		•
213-11472	BT50H160WE25 AD+B	50	25	160	65	72		•	
213-11473	BT50H160WE32 AD+B	50	32	160	72	-		•	

ZYLINDERSCHAFTAUFNAHME WELDON-LANG AUSFÜHRUNG
 END MILL HOLDERS WELDON-LONG PROJECTION TYPE
 ОПРАВКИ С КРЕПЛЕНИЕМ WELDON. УДЛИНЕННОЕ ИСПОЛНЕНИЕ.

MANDRINS POUR OUTILS TYPE WELDON-SERIE LONGUE
 MANDRINI PORTAFRESE TIPO WELDON-SERIE LUNGA
 威尔登式端铣夹具-加长凸点式

DIN 1835 B

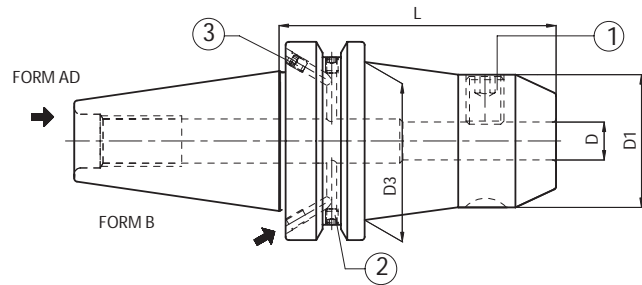

Code N.	Description	ISO	D	L	D1	D3	G6,3 ⁸⁰⁰⁰ RPM
213-11474	BT40H200WE06 AD+B	40	6	200	25	38	•
213-11475	BT40H200WE08 AD+B	40	8	200	28	41	•
213-11476	BT40H200WE10 AD+B	40	10	200	35	43	•
213-11477	BT40H200WE12 AD+B	40	12	200	42	48	•
213-11478	BT40H200WE14 AD+B	40	14	200	44	48	•
213-11479	BT40H200WE16 AD+B	40	16	200	48	-	•
213-11480	BT40H200WE18 AD+B	40	18	200	50	-	•
213-11481	BT40H200WE20 AD+B	40	20	200	52	-	•
213-11482	BT40H200WE25 AD+B	40	25	200	65	-	•
213-11483	BT40H200WE32 AD+B	40	32	200	72	-	•
213-11484	BT50H200WE06 AD+B	50	6	200	25	42	•
213-11485	BT50H200WE08 AD+B	50	8	200	28	45	•
213-11486	BT50H200WE10 AD+B	50	10	200	35	49	•
213-11487	BT50H200WE12 AD+B	50	12	200	42	55	•
213-11488	BT50H200WE14 AD+B	50	14	200	44	57	•
213-11489	BT50H200WE16 AD+B	50	16	200	48	60	•
213-11490	BT50H200WE18 AD+B	50	18	200	50	63	•
213-11491	BT50H200WE20 AD+B	50	20	200	52	63	•
213-11492	BT50H200WE25 AD+B	50	25	200	65	72	•
213-11463	BT50H200WE32 AD+B	50	32	200	72	-	•

H 200

Ersatzteile • Spare parts • Pièces détachées • Componenti • Запасные части • 零件

Type	Screw	Quantity	Screw	Quantity	D	Locking screw	Quantity
ISO 40	811-102002 M4X5	2	811-102002 M4X5	2	6	811-106001	1
ISO 50	811-102002 M4X5	2	811-102010 M5X6	2	8	811-106002	1
					10	811-106004	1
					12,14	811-106005	1
					16,18	811-106006	1
					20	811-106007	1
					25	811-106008	2
					32	811-106009	2

KURZE ZYLINDERSCHAFTAUFNAHME WELDON
SHORT END MILL WELDON HOLDERS
ОПРАВКИ С КРЕПЛЕНИЕМ WELDON. КОРОТКОЕ ИСПОЛНЕНИЕ

MANDRINS COURTS PORTE-FRAISE TYPE WELDON
MANDRINI CORTI PORTAFRESE TIPO WELDON
威尔登式短铣刀夹具

DIN 1835 B

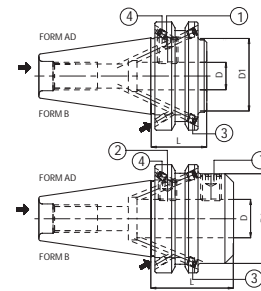

Code N.	Description	ISO	D	L	D1	G6,3 12000	
* 263-115600	BT30H35WE06 AD	30	6	35	25	-	
* 263-115610	BT30H35WE08 AD	30	8	35	28	-	
* 263-115620	BT30H35WE10 AD	30	10	35	35	-	
* 263-115630	BT30H35WE12 AD	30	12	35	42	-	
* 263-115640	BT30H35WE16 AD	30	16	35	42	-	
* 263-115650	BT30H35WE20 AD	30	20	35	43	-	
* 263-115660	BT30H35WE25 AD	30	25	35	45,5	-	
213-11493	BT40H35WE16 AD+B	40	16	35	44	•	*Ausführung Form AD
213-11494	BT40H35WE20 AD+B	40	20	35	44	•	
213-11495	BT40H35WE25 AD+B	40	25	35	44	•	*Execution form AD
213-11496	BT40H60WE25 AD+B	40	25	60	49	•	
213-11497	BT40H70WE32 AD+B	40	32	70	72	•	*Forme AD
213-11498	BT50H44WE16 AD+B	50	16	44	70	•	*Forma AD
213-11499	BT50H44WE20 AD+B	50	20	44	70	•	
263-11401	BT50H44WE25 AD+B	50	25	44	70	•	*Исполнение AD
263-11402	BT50H44WE32 AD+B	50	32	44	80	•	*执行形式 AD

Ersatzteile • Spare parts • Pièces détachées • Componenti • Запасные части • 零件

Extrakurze und feste Ausführung

Type	Screw	Quantity	Screw	Quantity
				
ISO40	811-102002 M4X5	2	811-102002 M4X5	2
ISO50	811-102002 M4X5	2	811-102010 M5X6	2

Extra short and Rigid Version
Экстракороткое и жесткое исполнение

Extra courts et version rigide

Extra corti e versione rigida

超短及坚固型

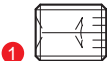
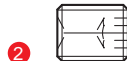
Code N.	Locking screw	Quantity	Locking screw	Quantity
				
263-115600	811-106001	1		
263-115610	811-106002	1		
263-115620	811-106004	1		
263-115630	811-106013	1		
263-115640	811-106026	1		
263-115650	811-106024	1		
263-115660	811-106026	1		
213-11493	811-106006	1		
213-11494	811-106027	1		
213-11495	811-106027	1		
213-11496	811-106014	1	811-106027	1
213-11497	811-106009	1	811-106046	1
213-11498	811-106006	1	-	
213-11499	811-106007	1	-	
263-11401	811-106008	1	-	
263-11402	811-106009	1	-	

ZYLINDERSCHAFTAUFNAHME WELDON MIT SPRITZDÜSEN
END MILL HOLDERS WELDON
WITH COOLANT NOOSE FRONT FACE
ОПРАВКИ С КРЕПЛЕНИЕМ WELDON И ОТВЕРСТИЯМИ
ДЛЯ СОЖ НА ТОРЦЕ

MANDRINS POUR OUTILS TYPE WELDON
AVEC BUSE D'ARROSAGE
MANDRINI PORTAFRESE TIPO WELDON
CON SFERE DI LUBRIFICAZIONE
威尔登式端铣夹具，配备出水结构

DIN 1835 B

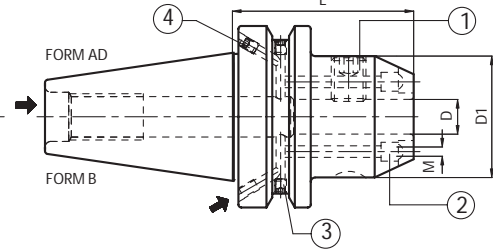
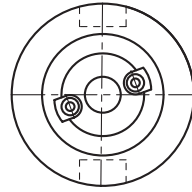

Code N.	Description	ISO	D	L	D1	G6,3 8000 RPM
263-11403	BT40H50WE06-CNFF AD+B	40	6	50	25	•
263-11404	BT40H50WE08-CNFF AD+B	40	8	50	28	•
263-11405	BT40H63WE10-CNFF AD+B	40	10	63	35	•
263-11406	BT40H63WE12-CNFF AD+B	40	12	63	42	•
263-11407	BT40H63WE14-CNFF AD+B	40	14	63	44	•
263-11408	BT40H63WE16-CNFF AD+B	40	16	63	48	•
263-11409	BT40H63WE18-CNFF AD+B	40	18	63	50	•
263-11410	BT40H63WE20-CNFF AD+B	40	20	63	52	•
263-11411	BT40H90WE25-CNFF AD+B	40	25	90	65	•
263-11412	BT40H100WE32-CNFF AD+B	40	32	100	72	•
263-11413	BT40H105WE40-CNFF AD+B	40	40	105	80	•
263-11414	BT50H63WE06-CNFF AD+B	50	6	63	25	•
263-11415	BT50H63WE08-CNFF AD+B	50	8	63	28	•
263-11416	BT50H70WE10-CNFF AD+B	50	10	70	35	•
263-11417	BT50H80WE12-CNFF AD+B	50	12	80	42	•
263-11418	BT50H80WE14-CNFF AD+B	50	14	80	44	•
263-11419	BT50H80WE16-CNFF AD+B	50	16	80	48	•
263-11420	BT50H80WE18-CNFF AD+B	50	18	80	50	•
263-11421	BT50H80WE20-CNFF AD+B	50	20	80	52	•
263-11422	BT50H100WE25-CNFF AD+B	50	25	100	65	•
263-11423	BT50H105WE32-CNFF AD+B	50	32	105	72	•
263-11424	BT50H120WE40-CNFF AD+B	50	40	120	80	•

Ersatzteile • Spare parts • Pièces détachées • Componenti • Запасные части • 零件

Ausführung mit Kühlmittelzufuhr zentral und an dem Bund.

Durch die seitlichen Bohrungen und die Kühlmitteldüsen ermöglicht dieses System das Kühlmittel direkt an den Kontaktpunkt des Werkzeuges zu leiten. Außerdem erfolgt Zentral-Kühlmittelzufuhr, wenn zwei Schrauben die Bohrungen verschliessen.

With central and lateral cooling possibility.

This type of system, thanks to two lateral holes, permits to direct the cooling jet through the two balls to the connection point of the tool.

Besides, with the application of two screws on the balls, you can have the lubrication through the centre.

Avec possibilité d'arrosage soit central, soit latéral.

Ce système, avec les trous latéraux, permet, avec les deux billes d'arrosage de diriger le liquide sur le point de contact de l'outil. De plus, il est possible d'avoir l'arrosage au centre en bouchant avec des vis les trous des billes.

Con possibilità di refrigerazione sia centrale che laterale.



Questo tipo di sistema grazie ai due fori laterali, permette, mediante le due sfere di dirigere il getto del refrigerante nel punto di contatto dell'utensile. Inoltre, con l'applicazione di due grandi sulle sfere si ottiene la lubrificazione attraverso il centro.

Возможность центрального и бокового охлаждения. Благодаря двум боковым отверстиям, эта система позволяет направлять СОЖ к месту крепления режущего инструмента. Если закрепить два винта в отверстиях фланца, СОЖ подается через центр.

具备中央及侧面冷却能力

这种类型的系统，由于具备两个侧孔，它可将冷却喷嘴通过两个球头导向工具的连接点。

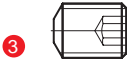
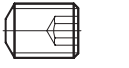
另外，在球头上使用两个螺丝，可使润滑剂通过中心。

Type	Screw	Quantity	Screw	Quantity
				
ISO40	811-102002 M4X5	2	811-102002 M4X5	2
ISO50	811-102002 M4X5	2	811-102010 M5X6	2
D	Locking screw	Quantity	Coolant noose	M
				
6	811-106001	1	PWZ1005D6x4.5	D2.5
8	811-106002	1	PWZ1005D6x4.5	D2.5
10	811-106004	1	PWZ1005D6x4.5	D2.5
12,14	811-106005	1	PWZ1005D6x4.5	D2.5
16,18	811-106006	1	PWZ1008D10x7	M4
20	811-106007	1	PWZ1008D10x7	M4
25	811-106008	2	PWZ1012D12x8	M5
32	811-106009	2	PWZ1012D12x8	M5
40	811-106009	2	PWZ1012D12x8	M5

ZYLINDERSCHAFTAUFNAHME WHISTLE NOTCH
 END MILL HOLDERS WHISTLE NOTCH
 ОПРАВКИ С КРЕПЛЕНИЕМ WHISTLE NOTCH

MANDRINS POUR OUTILS TYPE WHISTLE NOTCH
 MANDRINI PORTAFRESE TIPO WHISTLE NOTCH
 側固式铣刀柄

DIN 1835 E

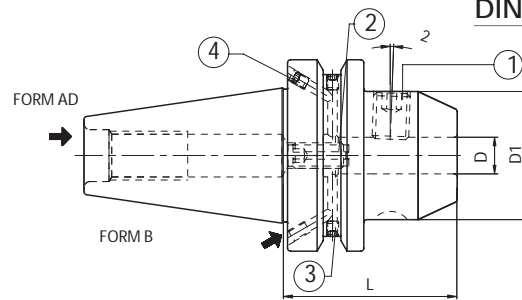

Code N.	Description	ISO	D	L	D1	G6,3 12000 RPM
213-31412	BT40H50WN06 AD+B	40	6	50	25	•
213-31413	BT40H50WN08 AD+B	40	8	50	28	•
213-31414	BT40H63WN10 AD+B	40	10	63	35	•
213-31415	BT40H63WN12 AD+B	40	12	63	42	•
213-31416	BT40H63WN14 AD+B	40	14	63	44	•
213-31417	BT40H63WN16 AD+B	40	16	63	48	•
213-31418	BT40H63WN18 AD+B	40	18	63	50	•
213-31419	BT40H63WN20 AD+B	40	20	63	52	•
213-31420	BT40H90WN25 AD+B	40	25	90	65	•
213-31421	BT40H100WN32 AD+B	40	32	100	72	•
213-31422	BT40H105WN40 AD+B	40	40	105	80	•
213-31423	BT50H63WN06 AD+B	50	6	63	25	•
213-31424	BT50H63WN08 AD+B	50	8	63	28	•
213-31425	BT50H70WN10 AD+B	50	10	70	35	•
213-31426	BT50H80WN12 AD+B	50	12	80	42	•
213-31427	BT50H80WN14 AD+B	50	14	80	44	•
213-31428	BT50H80WN16 AD+B	50	16	80	48	•
213-31429	BT50H80WN18 AD+B	50	18	80	50	•
213-31430	BT50H80WN20 AD+B	50	20	80	52	•
213-31431	BT50H100WN25 AD+B	50	25	100	65	•
213-31432	BT50H105WN32 AD+B	50	32	105	72	•
213-31433	BT50H120WN40 AD+B	50	40	120	80	•

Ersatzteile • Spare parts • Pièces détachées • Componenti • Запасные части • 零件

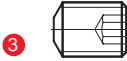
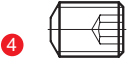
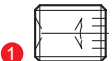
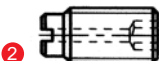
Type	Screw	Quantity	Screw	Quantity
				
ISO40	811-102002 M4X5	2	811-102002 M4X5	2
ISO50	811-102002 M4X5	2	811-102010 M5X6	2
D	Locking screw	Quantity	Stop screw	M
				
6	811-106001	1	811-303043	1
8	811-106002	1	811-303081	1
10	811-106004	1	811-303082	1
12,14	811-106005	1	811-303083	1
16,18	811-106006	1	811-303084	1
20	811-106007	1	811-303084	1
25	811-106008	2	811-303085	1
32	811-106009	2	811-303085	1
40	811-106009	2	811-303085	1

KOMBI - AUFSTECKFRÄSDORNE MANDRINS PORTE- FRAISE A DOUBLE USAGE
 COMBI-SHELL MILL ADAPTORS MANDRINI PORTAFRESE COMBINATI
 КОМБИНИРОВАННЫЕ ОПРАВКИ ДЛЯ НАСАДНЫХ ФРЕЗ 复合式平面铣刀接头

DIN 6358

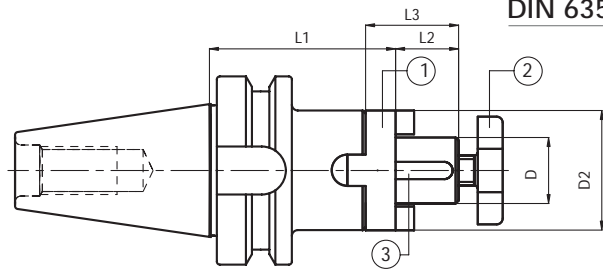

Code N.	Description	ISO	D	L1	L2	L3	D2	G6,3 8000 RPM
216-11527	BT30H50D16C	30	16	50	17	27	32	•
216-11528	BT30H50D22C	30	22	50	19	31	40	•
216-11529	BT30H55D27C	30	27	55	21	33	48	•
216-11501	BT40H55D16C	40	16	55	17	27	32	•
216-11502	BT40H55D22C	40	22	55	19	31	40	•
216-11503	BT40H55D27C	40	27	55	21	33	48	•
216-11504	BT40H60D32C	40	32	60	24	38	58	•
216-11505	BT40H60D40C	40	40	60	27	41	70	•
216-11507	BT50H70D16C	50	16	70	17	27	32	•
216-11508	BT50H70D22C	50	22	70	19	31	40	•
216-11509	BT50H70D27C	50	27	70	21	33	48	•
216-11510	BT50H70D32C	50	32	70	24	38	58	•
216-11511	BT50H70D40C	50	40	70	27	41	70	•

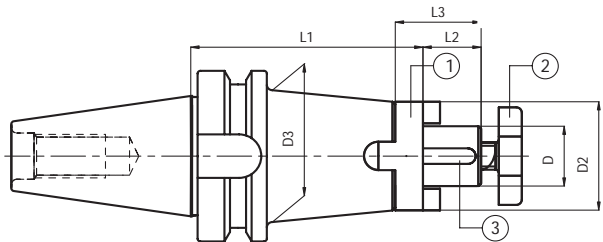

Code N.	Description	ISO	D	L1	L2	L3	D2	D3	G6,3 8000 RPM
216-11536	BT30H100D16C	30	16	100	17	27	32	-	•
216-11537	BT30H100D22C	30	22	100	19	31	40	-	•
216-11538	BT30H100D27C	30	27	100	21	33	48	-	•
216-11517	BT40H100D16C	40	16	100	17	27	32	44	•
216-11518	BT40H100D22C	40	22	100	19	31	40	-	•
216-11519	BT40H100D27C	40	27	100	21	33	48	-	•
216-11520	BT40H100D32C	40	32	100	24	38	58	-	•
216-11521	BT40H100D40C	40	40	100	27	41	70	-	•
216-11522	BT50H100D16C	50	16	100	17	27	32	44	•
216-11523	BT50H100D22C	50	22	100	19	31	40	50	•
216-11524	BT50H100D27C	50	27	100	21	33	48	60	•
216-11525	BT50H100D32C	50	32	100	24	38	58	-	•
216-11526	BT50H100D40C	50	40	100	27	41	70	-	•

Ersatzteile • Spare parts • Pièces détachées • Componenti • Запасные части • 零件

D	Ring	Cross screw	Key	Wrench
16	814-30001	811-107003	814-201010	816-130002
22	814-30002	811-107004	814-201020	816-130003
27	814-30003	811-107005	814-201030	816-130004
32	814-30004	811-107006	814-211040	816-130005
40	814-30005	811-107007	814-201050	816-130006

AUFSTECKFRÄSDORNE FÜR FRÄSER
MIT QUERNUT MIT GRÖßEREM BUND
FACE MILL HOLDERS-TENONS DRIVE
WITH BIGGER FLANGE DIAMETER
ОПРАВКИ ДЛЯ НАСАДНЫХ ФРЕЗ С УВЕЛИЧЕННЫМ
ДИАМЕТРОМ КОРПУСА

MANDRINS PORTE-FRAISE-ENTRAÎNEMENT
PAR TENONS BRIDE AJOUTÉE
MANDRINI PORTAFRESE A TRASCINAMENTO
FISSO CON FLANGIA MAGGIORATA
平面铣刀柄 - 凸榫驱动 - 配备更大法兰直径

ISO 3937

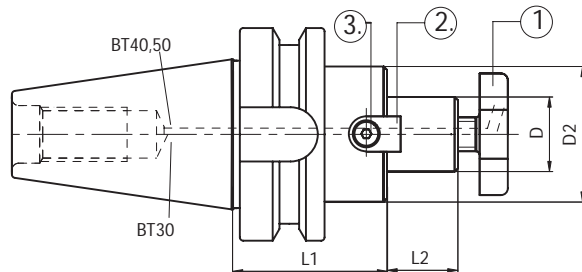

Code N.	Description	ISO	D	L1	L2	D2	G6,3 ⁸⁰⁰⁰ RPM
216-71501	BT30H35D16F	30	16	35	17	38	•
216-71502	BT30H40D22F	30	22	40	19	48	•
216-71503	BT30H40D27F	30	27	40	21	58	•
216-71507	BT40H45D16F	40	16	45	17	38	•
216-71508	BT40H45D22F	40	22	45	19	48	•
216-71509	BT40H45D27F	40	27	45	21	58	•
216-71510	BT40H50D32F	40	32	50	24	78	•
▲ 216-71511	BT40H55D40F	40	40	55	27	88	•
216-71517	BT50H60D16F	50	16	60	17	38	•
216-71518	BT50H60D22F	50	22	60	19	48	•
216-71519	BT50H60D27F	50	27	60	21	58	•
216-71520	BT50H60D32F	50	32	60	24	78	•
▲ 216-71521	BT50H60D40F	50	40	60	27	88	•

▲ Zur gebohrten Ausführung, sehen Sie bitte Seite 93

▲ For drilled version, please see on page 93

▲ Pour le modèle percé voir à la page 93

▲ Per versione forata vedi pag 93

▲ Оправки для фланцевого крепления фрез на стр. 93



Ersatzteile • Spare parts • Pièces détachées • Componenti • Запасные части • 零件

D	Cross screw	Cross screw on enquiry	Tenon	Screw	Wrench
16	811-107003	811-107013	814-202280	811-101004	816-130002
22	811-107004	811-107014	814-202250	811-101011	816-130003
27	811-107005	811-107015	814-202270	811-101018	816-130004
32	811-107006	811-107016	814-202630	811-101029	816-130005
40	811-107007	811-107017	814-202710	811-101029	816-130006

AUFSTECKFRÄSDORNE FÜR FRÄSER
MIT QUERNUT-LANGE AUSFÜHRUNG
FACE MILL HOLDERS-TENONS DRIVE-LONG PROJECTION TYPE
ОПРАВКИ ДЛЯ НАСАДНЫХ ФРЕЗ. УДЛИНЕННОЕ ИСПОЛНЕНИЕ

MANDRINS PORTE-FRAISE-ENTRAINEMENT
PAR TENONS-SERIE LONGUE
MANDRINI PORTAFRESE A TRASCINAMENTO FISSO-SERIE LUNGA
平面铣刀柄 - 凸榫驱动加长凸点式

ISO 3937

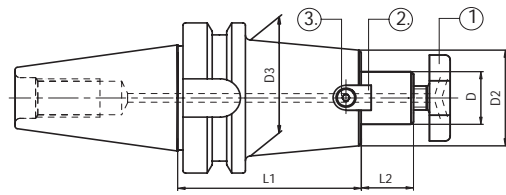

Code N.	Description	ISO	D	L1	L2	D2	D3		G6,3 8000	
H 100	216-71522	BT40H100D16F	40	16	100	17	39	-	-	•
	216-71526	BT40H100D22F	40	22	100	19	46	48	A	•
	216-71530	BT40H100D22F	40	22	100	19	50	59	B	•
	216-71599	BT40H100D27F	40	27	100	21	55	-	C	•
	266-71501	BT40H100D32F	40	32	100	24	66	-	-	•
	266-71502	BT40H100D40F	40	40	100	27	70	-	-	•
	216-71589	BT50H100D16F	50	16	100	17	39	-	-	•
	216-71534	BT50H100D22F	50	22	100	19	46	49	A	•
	216-71539	BT50H100D22F	50	22	100	19	50	60	B	•
	216-71544	BT50H100D27F	50	27	100	21	55	78	C	•
	216-71590	BT50H100D32F	50	32	100	24	66	78	-	•
	266-71503	BT50H100D40F	50	40	100	27	70	78	-	•
	H 160	216-71523	BT40H160D16F	40	16	160	17	39	-	-
216-71527		BT40H160D22F	40	22	160	19	46	48	A	•
216-71531		BT40H160D22F	40	22	160	19	50	59	B	•
216-71591		BT50H160D16F	50	16	160	17	39	-	-	•
216-71535		BT50H160D22F	50	22	160	19	46	49	A	•
216-71540		BT50H160D22F	50	22	160	19	50	60	B	•
216-71545		BT50H160D27F	50	27	160	21	55	78	C	•
216-71592		BT50H160D32F	50	32	160	24	66	78	-	•
266-71511	BT50H160D40F	50	40	160	27	70	78	-	•	
H 200	216-71524	BT40H200D16F	40	16	200	17	39	-	-	•
	216-71528	BT40H200D22F	40	22	200	19	46	48	A	•
	216-71593	BT50H200D16F	50	16	200	17	39	-	-	•
	216-71536	BT50H200D22F	50	22	200	19	46	49	A	•
	216-71541	BT50H200D22F	50	22	200	19	50	60	B	•
	216-71546	BT50H200D27F	50	27	200	21	55	78	C	•
	216-71594	BT50H200D32F	50	32	200	24	66	78	-	•
	266-71512	BT50H200D40F	50	40	200	27	70	78	-	•

A/Für Fräser D50 - B/Für Fräser D63 - C/Für Fräser D80

A/Suitable for milling cutters D50 - B/Suitable for milling cutters D63 - C/Suitable for milling cutters D80



A/подходит для фрез D50 - B/подходит для фрез D63 - C/подходит для фрез D80

A/Adaptes pour fraises D50 - B/Adaptes pour fraises D63 - C/Adaptes pour fraises D80

A/Adatti per frese D50 - B/Adatti per frese D63 - C/Adatti per frese D80

A/适用于 D50 铣刀 - B/适用于 D63 铣刀 - C/适用于 D80 铣刀

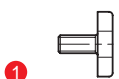
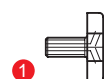
Ersatzteile • Spare parts • Pièces détachées • Componenti • Запасные части • 零件

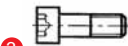
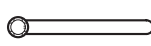
D/D2	Cross screw	Cross screw on enquiry	Tenon	Screw	Wrench
					
16	811-107003	811-107013	814-202280	811-101004	816-130002
22/46	811-107004	811-107014	814-202250	811-101011	816-130003
22/50	811-107004	811-107014	814-202260	811-101012	816-130003
27	811-107005	811-107015	814-202270	811-101017	816-130004
32	811-107006	811-107016	814-202290	811-101029	816-130005
40	811-107007	811-107017	814-202180	811-101028	816-130006



pag. 468-469



pag. 468-469



pag. 468-469

AUFSTECKFRÄSDORNE FÜR FRÄSER MIT QUERNUT UND KÜHLMITTELZUFUHR MIT GRÖßEREM BUND
FACE MILL HOLDERS-TENONS DRIVE WITH INTERNAL COOLANT SUPPLY WITH BIGGER FLANGE DIAMETER
ОПРАВКИ ДЛЯ НАСАДНЫХ ФРЕЗ С ВНУТРЕННЕЙ ПОДАЧЕЙ СОЖ И УВЕЛИЧЕННЫМ ДИАМЕТРОМ КОРПУСА

MANDRINS PORTE-FRAISE-ENTRAINEMENT PAR TENONS AVEC ARROSAGE INTERNE BRIDE AJOUTEE
MANDRINI PORTAFRESE A TRASCINAMENTO FISSO CON PASSAGGIO REFRIGERANTE CON FLANGIA MAGGIORATA
平面铣刀柄 - 凸榫驱动配备内部冷却剂供应带更大法兰直径

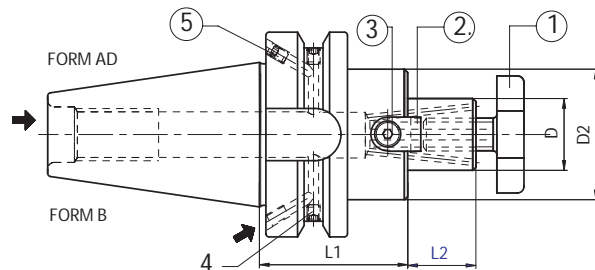

ISO 3937





Code N.	Description	ISO	D	L1	L2	D2	G6,3 ⁸⁰⁰⁰ RPM
216-71401	BT40H45D16F AD+B	40	16	45	17	38	•
216-71402	BT40H45D22F AD+B	40	22	45	19	48	•
216-71403	BT40H45D27F AD+B	40	27	45	21	58	•
216-71404	BT40H50D32F AD+B	40	32	50	24	78	•
216-71405	BT40H55D40F AD+B	40	40	55	27	88	•
216-71406	BT50H60D16F AD+B	50	16	60	17	38	•
216-71407	BT50H60D22F AD+B	50	22	60	19	48	•
216-71408	BT50H60D27F AD+B	50	27	60	21	58	•
216-71409	BT50H60D32F AD+B	50	32	60	24	78	•
216-71410	BT50H60D40F AD+B	50	40	60	27	88	•



Ersatzteile • Spare parts • Pièces détachées • Componenti • Запасные части • 零件

Tape	Screw	Quantity	Screw	Quantity
				
ISO 40	811-102002 M4X5	2	811-102002 M4X5	2
ISO 50	811-102002 M4X5	2	811-102010 M5X6	2

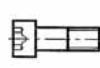
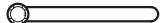
D	Cross screw	Tenon	Screw	Wrench
				
16	811-107003	814-202280	811-101004	816-130002
22	811-107004	814-202250	811-101011	816-130003
27	811-107005	814-202270	811-101018	816-130004
32	811-107006	814-202630	811-101029	816-130005
40	811-107007	814-202710	811-101029	816-130006

AUFSTECKFRÄSDORNE FÜR FRÄSER UND QUERNUT MIT
KÜHLMITTELZUFUHR-LANGE AUSFÜHRUNG
FACE MILL HOLDERS-TENONS DRIVE-WITH INTERNAL
COOLANT SUPPLY-LONG
ОПРАВКИ ДЛЯ НАСАДНЫХ ФРЕЗ С ВНУТРЕННЕЙ ПОДАЧЕЙ СОЖ.
УДЛИНЕННОЕ ИСПОЛНЕНИЕ

MANDRINS PORTE-FRAISE-ENTRAINEMENT PAR TENONS
AVEC ARROSAGE INTERNE-LONGUE
MANDRINI PORTAFRESE A TRASCINAMENTO FISSO
CON PASSAGGIO REFRIGERANTE-LUNGA
平面铣刀柄 - 凸榫驱动配备内部冷却剂供应加长

ISO 3937

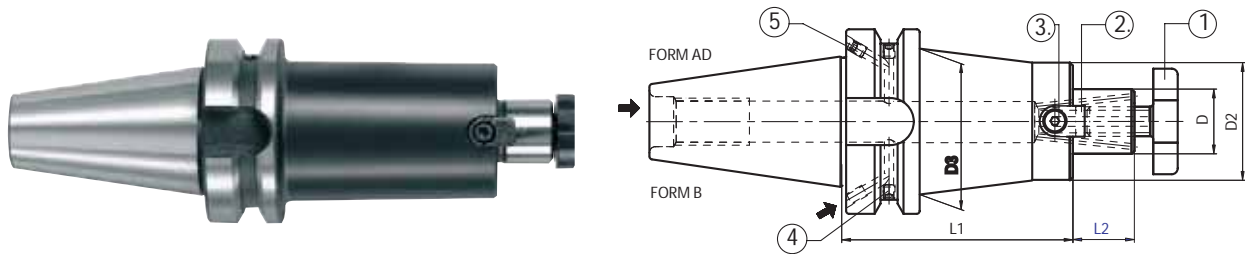

	Code N.	Description	ISO	D	L1	L2	D2	D3	G6,3 8000 RPM
H 100	216-71411	BT40H100D16F AD+B	40	16	100	17	32	40	•
	216-71412	BT40H100D22F AD+B	40	22	100	19	40	48	•
	216-71413	BT40H100D27F AD+B	40	27	100	21	48	-	•
	216-71414	BT40H100D32F AD+B	40	32	100	24	58	-	•
	216-71425	BT40H100D40F AD+B	40	40	100	27	70	-	•
	216-71415	BT50H100D16F AD+B	50	16	100	17	32	40	•
	216-71416	BT50H100D22F AD+B	50	22	100	19	40	52	•
	216-71417	BT50H100D27F AD+B	50	27	100	21	48	55	•
	216-71418	BT50H100D32F AD+B	50	32	100	24	58	65	•
	216-71419	BT50H100D40F AD+B	50	40	100	27	70	-	•



pag. 468-469







pag. 468-469

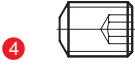
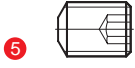

pag. 468-469

Ersatzteile • Spare parts • Pièces détachées • Componenti • Запасные части • 零件

Tape	Screw	Quantity	Screw	Quantity
				
ISO 40	811-102002 M4X5	2	811-102002 M4X5	2
ISO 50	811-102002 M4X5	2	811-102010 M5X6	2

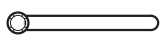
D	Cross screw	Tenon	Screw	Wrench
				
16	811-107003	814-20214	811-101003	816-130002
22	811-107004	814-20215	811-101010	816-130003
27	811-107005	814-20216	811-101017	816-130004
32	811-107006	814-20217	811-101027	816-130005
40	811-107007	814-20218	811-101028	816-130006

AUFSTECKFRÄSERDORNE FÜR MESSERKÖPFE
FACE MILL HOLDER FOR FACE MILLING CUTTERS
ОПРАВКИ ДЛЯ ФЛАНЦЕВОГО КРЕПЛЕНИЯ ФРЕЗ

MANDRINS PORTE-FRAISE POUR FRAISES A SURFACER
MANDRINI PORTAFRESE PER FRESE A SPIANARE
平面铣刀柄-夹持端铣刀

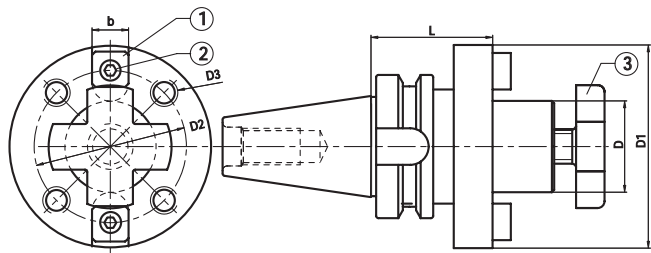

DIN 6357



Code N.	Description	ISO	D	L	D1	D2	D3	b	G6,3 8000 RPM
▲ 216-21501	BT40H60D40	40	40	60	89	66.7	M12	15.9	•
▲ 216-21502	BT50H70D40	50	40	70	89	66.7	M12	15.9	•
216-21503	BT50H80D60	50	60	80	129	101.6	M16	25.4	•

▲ INKLUSIVE INNENSCHARUBE • SUPPLIED WITH INTERNAL SCREW • ПОСТАВЛЯЕТСЯ С ВНУТРЕННИМ ВИНТОМ
VIS INTERNE INCLUSE • FORNITO CON VITE CENTRALE INCLUSA • 供货时提供内部螺丝

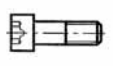
Ersatzteile • Spare parts • Pièces détachées • Componenti • Запасные части • 零件

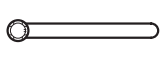
D	Tenon	Screw	Cross screw	Wrench
				
40	814-202080	811-101028	811-107007	816-130006
60	814-202120	811-101063	-	-

ZWISCHENHÜLSEN FÜR MORSEKEGEL MIT AUSTREIBLAPPEN
MORSE TAPER ADAPTORS FOR DRILLS
ОПРАВКИ ДЛЯ КОНУСА МОРСЕ С ЛАПКОЙ

DOUILLES POUR CONE MORSE A TENON
MANDRINI PORTAPUNTE ATTACCO CONO MORSE
莫氏锥度钻头接头

DIN 228-2 FORM D

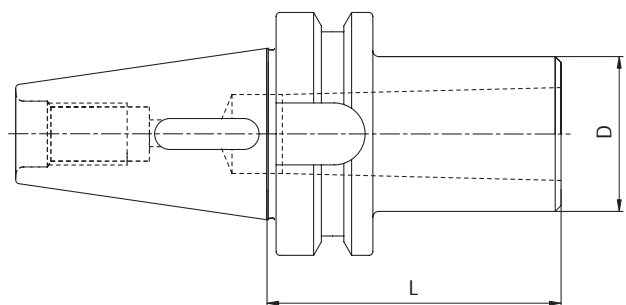

Code N.	Description	ISO	MORSE	D	L	G6,3 8000 RPM
212-41512	BT30H50CM1P	30	1	25	50	•
212-41513	BT30H60CM2P	30	2	32	60	•
212-41518	BT30H79CM3P	30	3	40	79	•
212-41501	BT40H50CM1P	40	1	25	50	•
212-41502	BT40H50CM2P	40	2	32	50	•
212-41503	BT40H70CM3P	40	3	40	70	•
212-41504	BT40H95CM4P	40	4	48	95	•
212-41519	BT50H45CM1P	50	1	25	45	•
212-41505	BT50H60CM2P	50	2	32	60	•
212-41506	BT50H65CM3P	50	3	40	65	•
212-41507	BT50H70CM4P	50	4	48	70	•
212-41508	BT50H105CM5P	50	5	63	105	•

ZWISCHENHÜLSEN FÜR MORSEKEGEL MIT ANZUGSGEWINDE
MORSE TAPER ADAPTER WITH THREAD
ОПРАВКИ ДЛЯ КОНУСА МОРСЕ С РЕЗЬБОЙ

DOUILLES POUR CONE MORSE AVEC TARAUDAGE
MANDRINI PORTAFRESE ATTACCO CONO MORSE
螺纹莫氏锥度接头

DIN 228-2 FORM C

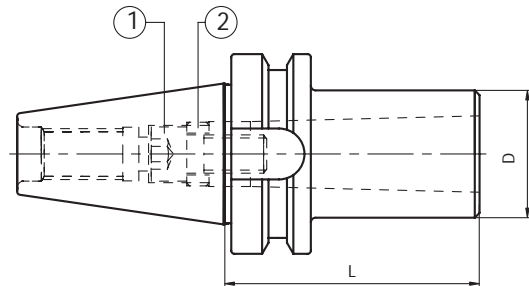

Code N.	Description	ISO	MORSE	D	L	G6,3 ⁸⁰⁰⁰ RPM
212-21502	BT40H50CM2F	40	2	32	50	•
212-21503	BT40H70CM3F	40	3	40	70	•
212-21504	BT40H95CM4F	40	4	48	95	•
212-21505	BT50H60CM2F	50	2	32	60	•
212-21506	BT50H65CM3F	50	3	40	65	•
212-21507	BT50H90CM4F	50	4	48	90	•

Ersatzteile • Spare parts • Pièces détachées • Componenti • Запасные части • 零件

BT/MORSE	Screw (BTA)	On enquiry	Ring
40/1	811-101029	-	811-302030
40/2	811-111007	811-111038	811-302031
40/3	811-111008	811-401098	811-302032
40/4	811-111005	811-401083	811-302036
50/1	811-101031	-	811-302030
50/2	811-101054	811-401084	811-302032
50/3	811-101065	811-401085	811-302032
50/4	811-401037	811-401086	811-302036
50/5	811-101092	811-401087	811-302034

ZWISCHENHÜLSEN FÜR MORSEKEGEL MIT ANZUGSGEWINDE
MORSE TAPER ADAPTER WITH THREAD
ОПРАВКИ ДЛЯ КОНУСА МОРЗЕ С РЕЗЬБОЙ



DOUILLES POUR CONE MORSE AVEC TARAUDAGE
MANDRINI PORTAFRESE ATTACCO CONO MORSE
螺纹莫氏锥度接头

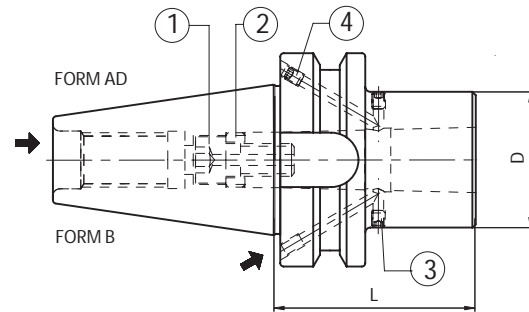

DIN 228-2 FORM C

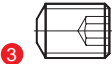

Code N.	Description	ISO	MORSE	D	L	G6,3 ⁸⁰⁰⁰ RPM
212-31405	BT40H50CM2F AD+B	40	2	32	50	•
212-31406	BT40H75CM3F AD+B	40	3	40	75	•
212-31407	BT40H95CM4F AD+B	40	4	48	95	•
212-31408	BT50H60CM2F AD+B	50	2	32	60	•
212-31409	BT50H65CM3F AD+B	50	3	40	65	•
212-31410	BT50H95CM4F AD+B	50	4	48	95	•

Ersatzteile • Spare parts • Pièces détachées • Componenti • Запасные части • 零件

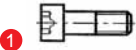
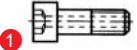
Tape/Morse	Screw	Quantity	Screw	Quantity
				
40/2	811-102002 M4X5	2	811-102002 M4X5	2
40/3:4	-	-	811-102002 M4X5	2
50/2:3:4	811-102002 M4X5	2	811-102010 M5X6	2
50/5	-	-	811-102010 M5X6	2

BT/MORSE	Screw (BTA)	On enquiry	Ring
			
40/2	811-111007	811-111038	811-302031
40/3	811-111008	811-401098	811-302032
40/4	811-111005	811-401083	811-302036
50/2	811-101054	811-401084	811-302032
50/3	811-101065	811-401085	811-302032
50/4	811-401037	811-401086	811-302036

ZWISCHENHÜSEN FÜR MORSEKEGEL
MIT AUSTREIBLAPPEN ODER ANZUGSGEWINDE
MORSE TAPER ADAPTORS FOR DRILLS AND MILLS
ОПРАВКИ ДЛЯ КОНУСОВ МОРЗЕ С ЛАПКОЙ И С РЕЗЬБОЙ

DOUILLES POUR CONE MORSE A TENON ET AVEC TARAUDAGE
MANDRINI PORTAPUNTE-PORTAFRESE
ATTACCO CONO MORSE
莫氏锥度钻铣接头

DIN 228-2 FORM C/D

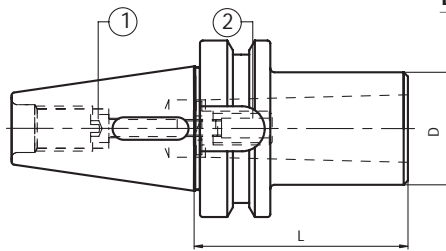

Kombi Version



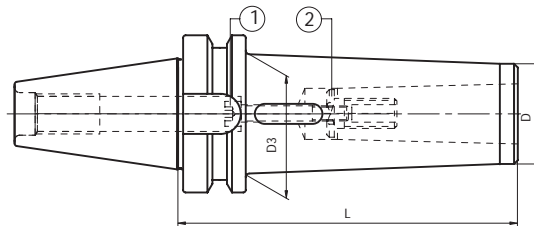

	Code N.	Description	ISO	MORSE	D	L	G6,3 8000 RPM
STANDARD	212-61518	BT40H50CM1P/F	40	1	25	50	•
	212-61519	BT40H60CM2P/F	40	2	32	60	•
	212-61520	BT40H76CM3P/F	40	3	40	76	•
	212-61522	BT50H45CM1P/F	50	1	25	45	•
	212-61523	BT50H60CM2P/F	50	2	32	60	•
	212-61524	BT50H65CM3P/F	50	3	40	65	•
	212-61525	BT50H95CM4P/F	50	4	48	95	•
	212-61526	BT50H120CM5P/F	50	5	63	120	•

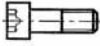

Kombi Version

	Code N.	Description	ISO	MORSE	D	D3	L	G6,3 8000 RPM
EXTENDED	212-61502	BT40H125CM2P/F	40	2	25	32	125	•
	212-61503	BT40H140CM3P/F	40	3	33	40	140	•
	212-61505	BT50H120CM1P/F	50	1	18	25	120	•
	212-61506	BT50H140CM2P/F	50	2	25	32	140	•
	212-61507	BT50H150CM3P/F	50	3	33	40	150	•
	212-61508	BT50H180CM4P/F	50	4	40	48	180	•

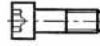
Ersatzteile • Spare parts • Pièces détachées • Componenti • Запасные части • 零件

	Code N.	Screw	Ring		Code N.	Screw	Ring
STANDARD				EXTENDED			
	212-61518	811-101033	-		212-61502	811-401015	-
	212-61519	811-401018	-		212-61503	811-101081	811-302006
	212-61520	811-101034	811-302006		212-61505	811-101077	-
	212-61523	811-101057	-		212-61506	811-101078	-
	212-61524	811-101071	-		212-61507	811-101079	-
	212-61525	811-401016	-		212-61508	811-401030	-
	212-61526	811-101071	811-302008				

JIS-B 6339 MAS 403/BT AD/B

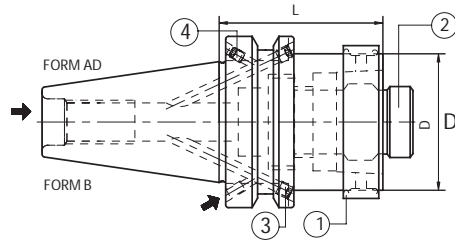

ZWISCHENHÜSLEN BT X HSK A+C - MANUELLES SPANNSYSTEM
TAPER ADAPTER BT X HSK A+C - MANUAL CLAMPING
ПЕРЕХОДНЫЕ ОПРАВКИ BT - HSK A+C - РУЧНАЯ УСТАНОВКА

DOUILLES INTERMEDIAIRES BT X HSK A+C - SERRAGE MANUEL
MANDRINI RIDUZIONE DA BT A HSK A+C - CHIUSURA MANUALE
BT X HSK A+C 锥度接头 - 手动夹紧

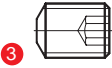

Code N.	Description	ISO	HSK	D	L	1 Ring (complete)	2 Locking unit (complete)
212-91401	BT40H60HSK50 AD+B	40	50	50	60	H50A-AN	H50A-UBL
212-91402	BT40H80HSK63 AD+B	40	63	63	80	H63A-AN	H63A-UBL
212-91403	BT50H65HSK50 AD+B	50	50	50	65	H50A-AN	H50A-UBL
212-91404	BT50H70HSK63 AD+B	50	63	63	70	H63A-AN	H63A-UBL

Ersatzteile • Spare parts • Pièces détachées • Componenti • Запасные части • 零件

Tape	Screw	Quantity	Screw	Quantity
				
ISO 40	811-102002 M4X5	2	811-102002 M4X5	2
ISO 50	811-102010 M5X6	2	811-102010 M5X6	2

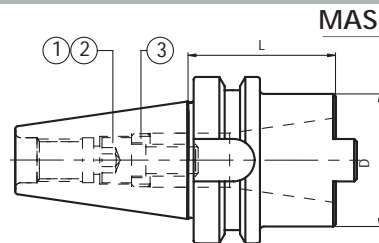

ZWISCHENHÜSLEN BT X SK
ISO TAPER ADAPTORS
ПЕРЕХОДНЫЕ ОПРАВКИ BT - SK

DOUILLES INTERMEDIAIRES BT X SA
MANDRINI RIDUZIONE E PROLUNGHE DA MS403/BT A DIN2080/DIN69871/MAS403BT
ISO 锥度接头



Code N.	Description	ISO	ISO	D	L
212-11504	BT40H63ISO30/TC30	40	30	52	63
212-11508	BT40H100ISO40/TC40	40	40	68	100
212-11507	BT50H70ISO40/TC40	50	40	78	70
212-11509	BT50H120ISO50/TC50	50	50	100	120

Ersatzteile • Spare parts • Pièces détachées • Componenti • Запасные части • 零件

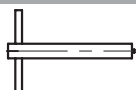
OUTSIDE	INSIDE	Screw (ISO)	Screw (TC)	Ring	Wrench
					
40	30	811-401098	811-401145	811-302032	816-20206002
40	40	811-401147	811-401150	811-302036	816-20207002
50	40	811-401147	811-401150	811-302036	816-20207002
50	50	811-401151	811-401152	811-302047	816-202090

Verschlußschraube für DIN69871/MAS BT/DIN2080 wird mitgeliefert und ist durchbohrt
Supplied with a bored screw DIN69871/MAS BT/DIN2080
Livré avec une vis de serrage DIN69871/MAS BT/DIN2080 percée
In dotazione vite per chiusura DIN69871/MAS BT/DIN2080 forata
Поставляется с винтом с отверстием для DIN69871/MAS BT/DIN2080
提供 DIN69871/MAS BT/DIN2080 无铆螺钉一个

SPANNZANGENFUTTER ER TYP MANDRINS A PINCES TYPE ER
 ER COLLET CHUCK MANDRINI PORTAPINZA TIPO ER
 ЦАНГОВЫЕ ПАТРОНЫ ER ER 弹簧夹头

DIN 6499

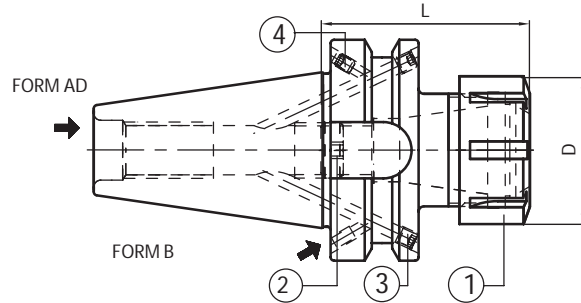





Code N.	Description	ISO	ER	D	L	G2,5 25000 RPM
214-91401	BT40H70ER16 AD+B	40	16	32	70	•
214-91402	BT40H70ER25 AD+B	40	25	42	70	•
214-91403	BT40H70ER32 AD+B	40	32	50	70	•
214-91404	BT40H70ER40 AD+B	40	40	63	70	•
214-91405	BT50H80ER25 AD+B	50	25	42	80	•
214-91406	BT50H80ER32 AD+B	50	32	50	80	•
214-91407	BT50H80ER40 AD+B	50	40	63	80	•

Zubehör
 Accessories
 Accessoires
 Accessori
 Принадлежности
 零件



High balanced

Ersatzteile • Spare parts • Pièces détachées • Componenti • Запасные части • 零件

Type	Screw	Quantity	Screw	Quantity	ER	Nut	Stop screw
							
ISO 40	811-102002 M4X5	2	811-102002 M4X5	2	16	812-203069	811-303119
ISO 50	811-102002 M4X5	2	811-102010 M5X6	2	25	812-203070	811-303121
					32	812-203071	811-303118
					40	812-203072	811-303122

SPANNZANGENFUTTER ER TYP-LANG ER COLLET CHUCK-LONG
 ЦАНГОВЫЕ ПАТРОНЫ ER. УДЛИНЕННОЕ ИСПОЛНЕНИЕ

MANDRINS A PINCES TYPE ER-SERIE LONGUE
 MANDRINI PORTAPINZA TIPO ER-SERIE LUNGA
 ER 弹簧夹头-加长

DIN 6499

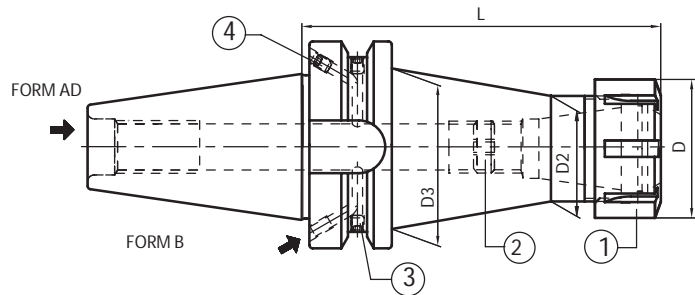

Code N.	Description	ISO	ER	D	L	D2	D3	G2,5 25000 RPM	
H 100	214-91408	BT40H100ER16 AD+B	40	16	32	100	22	32	•
	214-91409	BT40H100ER25 AD+B	40	25	42	100	32	42	•
	214-91410	BT40H100ER32 AD+B	40	32	50	100	40	50	•
	214-91411	BT40H100ER40 AD+B	40	40	63	100	50	50	•
	214-91412	BT50H100ER16 AD+B	50	16	32	100	22	32	•
	214-91413	BT50H100ER25 AD+B	50	25	42	100	32	42	•
	214-91414	BT50H100ER32 AD+B	50	32	50	100	40	50	•
	214-91415	BT50H100ER40 AD+B	50	40	63	100	50	63	•

Zubehör
 Accessories
 Accessoires
 Accessori
 Принадлежности
 零件

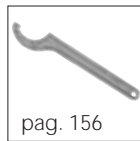

High balanced

Ersatzteile • Spare parts • Pièces détachées • Componenti • Запасные части • 零件

Tap	Screw	Quantity	Screw	Quantity	ER	Nut	Stop screw
ISO 40	811-102002 M4X5	2	811-102002 M4X5	2	16	812-203069	811-303119
ISO 50	811-102002 M4X5	2	811-102010 M5X6	2	25	812-203070	811-303121
					32	812-203071	811-303118
					40	812-203072	811-303122

SPANNZANGENFUTTER ER MINI
ER MINI COLLET CHUCK
ЦАНГОВЫЕ МИНИ-ПАТРОНЫ ER

MANDRINS A PINCES TYPE ER MINI
MANDRINI PORTAPINZA TIPO ER MINI EXTRA SOTTILI
ER 迷你弹簧夹头

DIN 6499

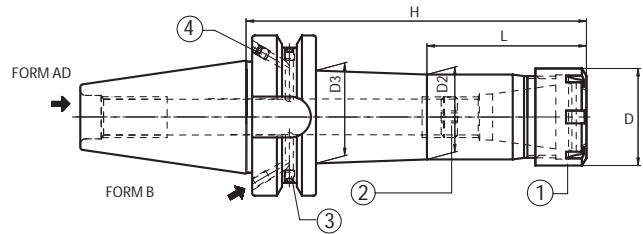





Code N.	Description	ISO	ER	D	H	L	D2	D3	G6,3 12000 RPM
214-91448*	BT30H70ER11M	30	11M	16	70	20	14	19	•
214-91449*	BT30H100ER11M	30	11M	16	100	20	14	20	•
214-91433	BT40H70ER11M AD+B	40	11M	16	70	20	14	20	•
214-91434	BT40H100ER11M AD+B	40	11M	16	100	40	14	20	•
214-91435	BT40H160ER11M AD+B	40	11M	16	160	50	14	28	•
214-91436	BT40H70ER16M AD+B	40	16M	22	70	27	20	25	•
214-91437	BT40H100ER16M AD+B	40	16M	22	100	47	20	26	•
214-91438	BT40H160ER16M AD+B	40	16M	22	160	97	20	26	•
214-91450	BT40H70ER20M AD+B	40	20M	28	70	-	26	-	•
214-91451	BT40H100ER20M AD+B	40	20M	28	100	48	26	30	•
214-91452	BT40H160ER20M AD+B	40	20M	28	160	98	26	31	•
214-91439	BT40H70ER25M AD+B	40	25M	35	70	-	33	-	•
214-91440	BT40H100ER25M AD+B	40	25M	35	100	-	33	-	•
214-91441	BT40H160ER25M AD+B	40	25M	35	160	103	33	35	•
214-91442	BT50H70ER16M AD+B	50	16M	22	70	-	22	-	•
214-91443	BT50H100ER16M AD+B	50	16M	22	100	47	22	26	•
214-91444	BT50H160ER16M AD+B	50	16M	22	160	97	22	28	•
214-91445	BT50H70ER25M AD+B	50	25M	35	70	-	35	-	•
214-91446	BT50H100ER25M AD+B	50	25M	35	100	-	35	-	•
214-91447	BT50H160ER25M AD+B	50	25M	35	160	103	35	40	•

- * BT30 nur AD Ausführung
- * BT30 only AD version
- * BT 30 только с AD исполнением
- * BT30 seulement Version AD
- * BT30 solo versione AD
- * BT30 只在AD版本下



Slim Line

Ersatzteile • Spare parts • Pièces détachées • Componenti • Запасные части • 零件

Tape	Screw	Quantity	Screw	Quantity	ER	Nut	Stop screw
							
ISO 40	811-102002 M4X5	2	811-102002 M4X5	2	11M	812-203012	811-303081
ISO 50	811-102002 M4X5	2	811-102010 M5X6	2	16M	812-203013	811-303119
					20M	812-203014	811-303120
					25M	812-203015	811-303121

SPANNZANGENFUTTER ER TYP MANDRINS A PINCES TYPE ER
 ER COLLET CHUCK MANDRINI PORTAPINZA TIPO ER
 ЦАНГОВЫЕ ПАТРОНЫ ER ER 弹簧夹头

DIN 6499

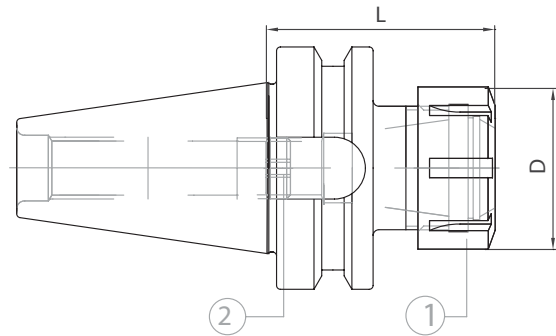

Code N.	Description	ISO	ER	D	L	G6,3 ¹²⁰⁰⁰ RPM
214-31511	BT30H60ER16	30	16	32	60	•
214-31512	BT30H60ER25	30	25	42	60	•
214-31513	BT30H60ER20	30	20	35	60	•
214-31525	BT30H60ER32	30	32	50	60	•
214-31539	BT40H70ER16	40	16	32	70	•
214-31501	BT40H70ER25	40	25	42	70	•
214-31502	BT40H70ER32	40	32	50	70	•
214-31515	BT40H70ER40	40	40	63	70	•
214-31584	BT50H70ER16	50	16	32	70	•
214-31549	BT50H80ER25	50	25	42	80	•
214-31503	BT50H80ER32	50	32	50	80	•
214-31504	BT50H80ER40	50	40	63	80	•

Ersatzteile • Spare parts • Pièces détachées • Componenti • Запасные части • 零件

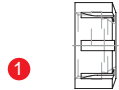
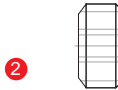
ER	Nut	Stop screw
		
16	812-203005	811-303119
25	812-203001	811-303121
32	812-203002	811-303118
40	812-203003	811-303122

SPANNZANGENFUTTER ER TYP-LANG
 ER COLLET CHUCK-LONG
 ЦАНГОВЫЕ ПАТРОНЫ ER. УДЛИНЕННОЕ ИСПОЛНЕНИЕ

MANDRINS A PINCES TYPE ER-SERIE LONGUE
 MANDRINI PORTAPINZA TIPO ER-SERIE LUNGA
 ER 弹簧夹头-加长

DIN 6499

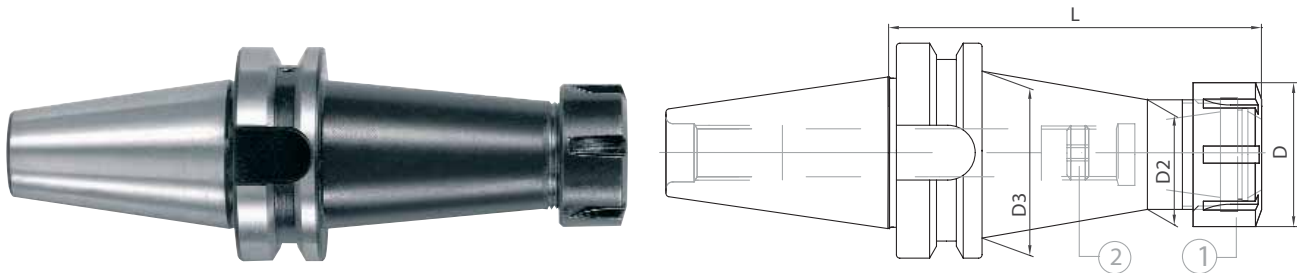

Code N.	Description	ISO	ER	D	L	D2	D3	G6,3 12000 RPM
214-31520	BT30H100ER16	30	16	32	100	22	24	•
214-31538	BT30H100ER25	30	25	42	100	32	40	•
214-31527	BT40H100ER16	40	16	32	100	22	28	•
214-31542	BT40H100ER25	40	25	42	100	32	42	•
214-31545	BT40H100ER32	40	32	50	100	40	50	•
214-31583	BT40H100ER40	40	40	63	100	50	50	•

Ersatzteile • Spare parts • Pièces détachées • Componenti • Запасные части • 零件

ER	Nut	Stop screw
16	812-203005	811-303119
25	812-203001	811-303121
32	812-203002	811-303118
40	812-203003	811-303122

SPANNZANGENFUTTER ER TYP MANDRINS A PINCES TYPE ER
 ER COLLET CHUCK MANDRINI PORTAPINZA TIPO ER
 ЦАНГОВЫЕ ПАТРОНЫ ER ER 弹簧夹头

DIN 6499

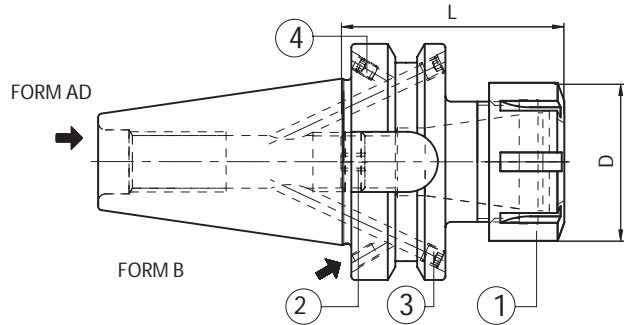

STANDARD	Code N.	Description	ISO	ER	D	L	G6,3 12000 RPM
	214-31447	BT40H70ER16 AD+B	40	16	32	70	•
	214-31422	BT40H70ER25 AD+B	40	25	42	70	•
	214-31423	BT40H70ER32 AD+B	40	32	50	70	•
	214-31424	BT40H70ER40 AD+B	40	40	63	70	•
	214-31469	BT50H80ER16 AD+B	50	16	32	80	•
	214-31429	BT50H80ER25 AD+B	50	25	42	80	•
	214-31430	BT50H80ER32 AD+B	50	32	50	80	•
	214-31431	BT50H80ER40 AD+B	50	40	63	80	•

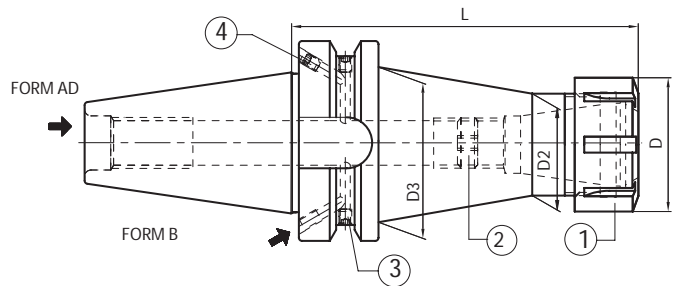

H 100	Code N.	Description	ISO	ER	D	L	D2	D3	G6,3 12000 RPM
	214-31520	BT30H100ER16 AD+B	30	16	32	100	22	32	•
	214-31538	BT30H100ER25 AD+B	30	25	42	100	32	42	•
	214-31448	BT40H100ER16 AD+B	40	16	32	100	22	32	•
	214-31439	BT40H100ER25 AD+B	40	25	42	100	32	42	•
	214-31440	BT40H100ER32 AD+B	40	32	50	100	40	50	•
	214-31449	BT40H100ER40 AD+B	40	40	63	100	50	50	•
	214-31450	BT50H100ER16 AD+B	50	16	32	100	22	32	•
	214-31438	BT50H100ER25 AD+B	50	25	42	100	32	42	•
	214-31434	BT50H100ER32 AD+B	50	32	50	100	40	50	•
214-31436	BT50H100ER40 AD+B	50	40	63	100	50	63	•	

* Ausführung Form AD * Forma AD
 * Execution form AD * Исполнение AD
 * Forme AD * 执行形式 AD

Zubehör
 Accessories
 Accessoires
 Accessori
 Принадлежности
 零件

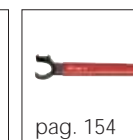

SPANNZANGENFUTTER ER TYP-LANGE AUSFÜHRUNG
ER COLLET CHUCK-LONG
ЦАНГОВЫЕ ПАТРОНЫ ER. УДЛИНЕННОЕ ИСПОЛНЕНИЕ



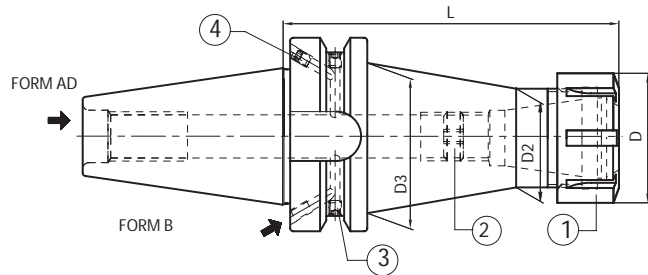

MANDRINS A PINCES TYPE ER-SERIE LONGUE
MANDRINI PORTAPINZA TIPO ER-SERIE LUNGA
ER 弹簧夹头-加长

DIN 6499



	Code N.	Description	ISO	ER	D	L	D2	D3	G6,3 8000 RPM
H 160	214-31442	BT40H160ER16 AD+B	40	16	32	160	22	32	•
	214-31432	BT40H160ER25 AD+B	40	25	42	160	32	42	•
	214-31433	BT40H160ER32 AD+B	40	32	50	160	40	50	•
	214-31451	BT40H160ER40 AD+B	40	40	63	160	50	50	•
	214-31452	BT50H160ER16 AD+B	50	16	32	160	22	32	•
	214-31453	BT50H160ER25 AD+B	50	25	42	160	32	42	•
	214-31435	BT50H160ER32 AD+B	50	32	50	160	40	50	•
	214-31437	BT50H160ER40 AD+B	50	40	63	160	50	63	•
H 200	214-31454	BT40H200ER16 AD+B	40	16	32	200	22	32	•
	214-31455	BT40H200ER25 AD+B	40	25	42	200	32	42	•
	214-31456	BT40H200ER32 AD+B	40	32	50	200	40	50	•
	214-31457	BT40H200ER40 AD+B	40	40	63	200	50	50	•
	214-31458	BT50H200ER16 AD+B	50	16	32	200	22	32	•
	214-31459	BT50H200ER25 AD+B	50	25	42	200	32	42	•
	214-31460	BT50H200ER32 AD+B	50	32	50	200	40	50	•
	214-31461	BT50H200ER40 AD+B	50	40	63	200	50	63	•

Ersatzteile • Spare parts • Pièces détachées • Componenti • Запасные части • 零件

Tap	Screw	Quantity	Screw	Quantity	ER	Nut	Stop screw
							
ISO 40	811-102002 M4X5	2	811-102002 M4X5	2	16	812-203005	811-303119
ISO 50	811-102002 M4X5	2	811-102010 M5X6	2	25	812-203001	811-303121
					32	812-203002	811-303118
					40	812-203003	811-303122

Zubehör
Accessories
Accessoires
Accessori
Принадлежности
零件



SPANNZANGENFUTTER EOC TYP ER COLLET CHUCK
MANDRINS A PINCES TYPE EOC MANDRINI PORTAPINZA TIPO EOC
ЦАНГОВЫЕ ПАТРОНЫ EOC ER 弹簧夹头

DIN 6388

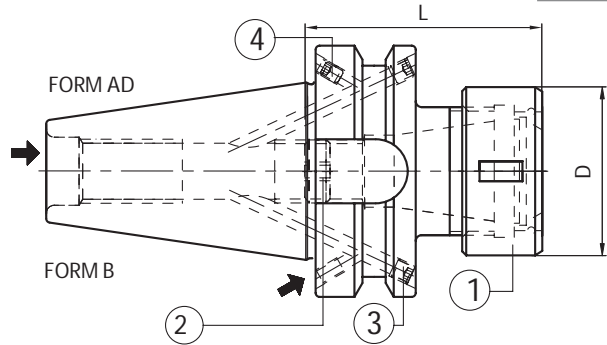

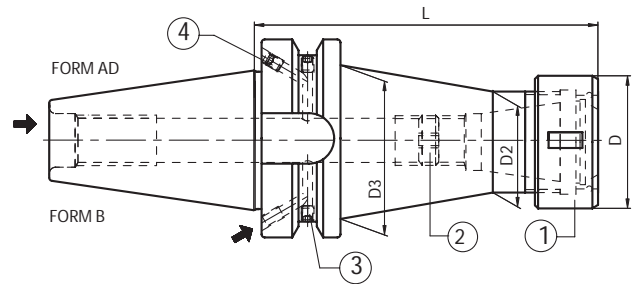

Code N.	Description	ISO	EOC	D	L	G6,3 12000 RPM
214-11401	BT40H70EOC16 AD+B	40	16	43	70	•
214-11402	BT40H70EOC25 AD+B	40	25	60	70	•
214-11403	BT50H85EOC25 AD+B	50	25	60	85	•
214-11404	BT50H90EOC32 AD+B	50	32	72	90	•





Code N.	Description	ISO	EOC	D	L	D2	D3	G6,3 8000 RPM
H130 214-11405	BT40H130EOC16 AD+B	40	16	43	130	33	42	•
214-11406	BT40H130EOC25 AD+B	40	25	60	130	48	48	•
214-11408	BT50H130EOC25 AD+B	50	25	60	130	48	48	•
214-11409	BT50H130EOC32 AD+B	50	32	72	130	60	60	•

Ersatzteile • Spare parts • Pièces détachées • Componenti • Запасные части • 零件

Zubehör
Accessories
Accessoires
Accessori
Принадлежности
零件

Tape	Screw	Quantity	Screw	Quantity
				
ISO 40	811-102002 M4X5	2	811-102002 M4X5	2
ISO 50	811-102002 M4X5	2	811-102010 M5X6	2

EOC	Nut	Stop screw	Wrench
			
16	GOC16	811-303121	816-203033
25	GOC25	811-303123	816-203034
32	GOC32	811-303123	816-203036

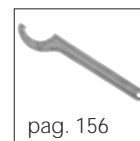

JIS-B 6339 MAS 403/BT AD/B

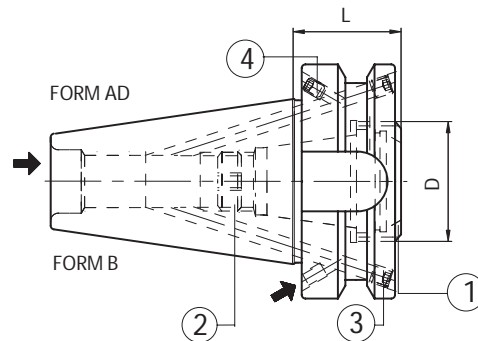

SPANNZANGENFUTTER ER TYP-LÄNGE EXTRAKURZ
ER COLLET CHUCK WITH INSIDE NUT
ЦАНГОВЫЕ ПАТРОНЫ ER С ВНУТРЕННЕЙ ГАЙКОЙ

MANDRINS COURTS A PINCES TYPE ER
MANDRINI PORTAPINZA TIPO ER EXTRACORTI
ER 弹簧夹头带内部螺母





Code N.	Description	ISO	ER	D	L	G6,3 12000 RPM
214-31462	BT40H29ER25A AD+B	40	25A	32	29	•
*214-31571	BT40H29ER32A	40	32A	40	29	•
214-31463	BT50H40ER32A AD+B	50	32A	40	40	•

Ersatzteile • Spare parts • Pièces détachées • Componenti • Запасные части • 零件

Tape	Screw	Quantity	Screw	Quantity
				
ISO 40	811-102002 M4X5	2	811-102002 M4X5	2
ISO 50	811-102010 M5X6	2	811-102010 M5X6	2

- * Ausführung Form AD
- * Execution form AD
- * Forme AD
- * Forma AD
- * Исполнение AD
- * 执行形式 AD

ER	Nut	Stop screw	Wrench
			
25A	812-203057	811-303121	CHER25EX
32A	812-203032	811-303118	CHER32EX

MAS 403/BT A

BOHRFUTTERAUFNAHMEN
ARBORS FOR DRILL CHUCKS
ОПРАВКИ ДЛЯ СВЕРЛИЛЬНЫХ ПАТРОНОВ

ARBRES POUR MANDRINS DE PERCAGE
ATTACCO PER MANDRINI PORTAPUNTE
钻夹头刀杆

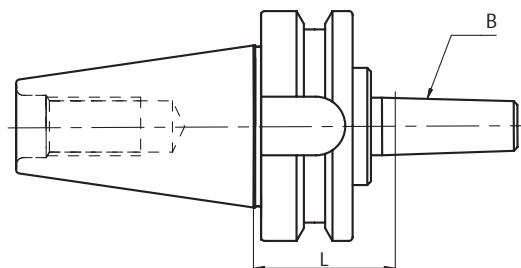

DIN 238

Code N.	Description	ISO	B	L	G6,3 8000 RPM
216-31502	BT40H40B16	40	16	40	•
216-31503	BT40H40B18	40	18	40	•
216-31505	BT50H50B16	50	16	50	•
216-31506	BT50H50B18	50	18	50	•

OPERATING MANUAL FOR HYDRAULIC EXPANSION CHUCKS MANUALE OPERATIVO PER L'UTILIZZO DEI MANDRINI IDRAULICI
 ИНСТРУКЦИЯ ПО ПРИМЕНЕНИЮ ГИДРАВЛИЧЕСКИХ ПАТРОНОВ

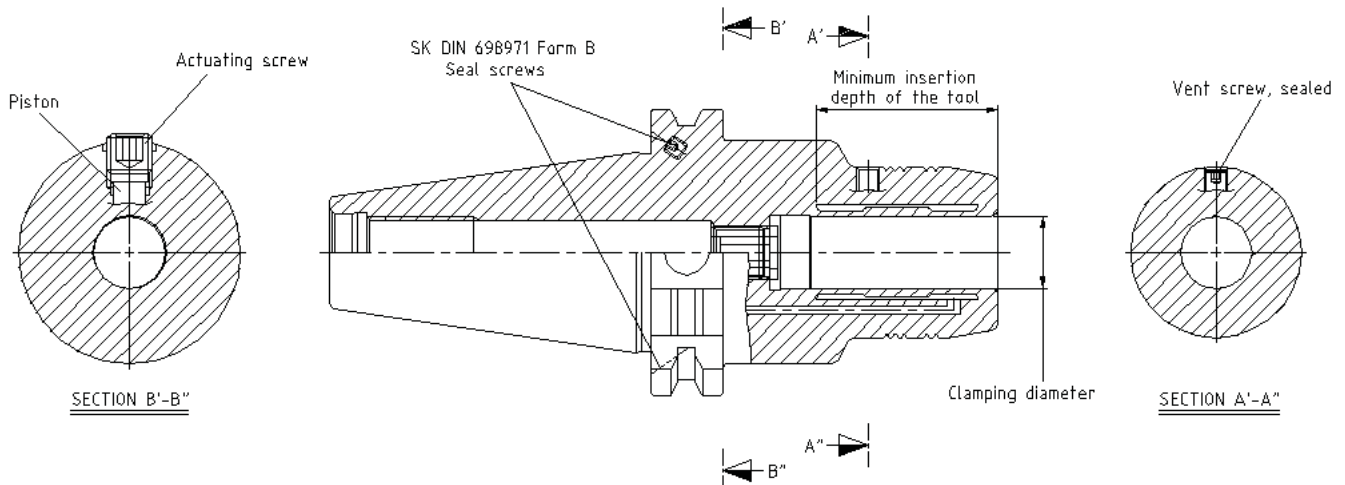

- Please follow our operating instruction carefully to save time and avoid problems
Пожалуйста, следуйте нашим инструкциям, чтобы избежать проблем и потери времени.
 Raccomandiamo di seguire le nostre istruzioni operative per risparmiare tempo ed evitare problemi

Chart of technical data

Таблица с техническими характеристиками:

Tabella delle informazioni tecniche

Chuck Diameter (HC)	Shaft Clamping	Depending on the mounting shank (max RPM)	Minimum clamping length (mm)	Operating temperature	Max coolant pressure (bar)	Moment (Nm)
HC6	6 hb	40.000	27	20-50	80	8 Nm
HC8	8 hb	40.000	27	20-50	80	15 Nm
HC10	10 hb	40.000	32	20-50	80	30 Nm
HC12	12 hb	40.000	37	20-50	80	45 Nm
HC14	14 hb	40.000	37	20-50	80	75 Nm
HC16	16 hb	40.000	42	20-50	80	120 Nm
HC18	18 hb	40.000	42	20-50	80	170 Nm
HC20	20 hb	40.000	42	20-50	80	230 Nm
HC25	25 hb	25.000	48	20-50	80	300 Nm
HC32	32 hb	25.000	55	20-50	80	400 Nm

- The clamping force must be checked periodically. We recommend to check it before initial use and approximately after 100 operations or every 3 months.
Усилие зажима необходимо периодически проверять. Мы рекомендуем производить проверку перед первым использованием, далее примерно каждые 100 операций или каждые 3 месяца.
 La verifica della forza di serraggio deve essere fatta periodicamente. Si raccomanda di controllarla prima dell'utilizzo e dopo circa 100 operazioni o ogni 3 mesi

ATTENTION / **ВНИМАНИЕ** / ATTENZIONE

- When tools or endmills are clamped into the hydraulic chucks, be sure that oils and dust are completely removed from the internal surface of the hydraulic chuck and the external surface of the tool
При установке инструмента в гидropатроне, убедитесь, что на внутренней поверхности патрона и внешней поверхности инструмента нет масла и пыли.
 Quando si montano gli utensili o le frese nel mandrino idraulico, la superficie interna del mandrino idraulico e quella esterna dell'utensile devono essere pulite da oli, polveri e residui

HYDRO-DEHNSPANNFUTTER FÜR WERKZEUGE MIT ZYLINDERSCHAFT
 HYDRO-EXPANSION CHUCKS FOR TOOLS WITH CYLINDRICAL SHANK
 ГИДРАВЛИЧЕСКИЕ ПАТРОНЫ ДЛЯ ИНСТРУМЕНТА
 С ЦИЛИНДРИЧЕСКИМ ХВОСТОВИКОМ

MANDRINS HYDRO-EXPANSIBLES POUR OUTILS
 A QUEUE CYLINDRIQUE
 MANDRINI IDRAULICI PER UTENSILI ATTACCO CILINDRICO
 适用圆柱刀柄的液压膨胀夹头

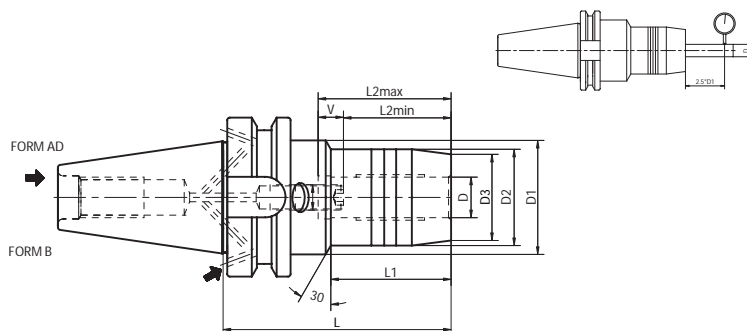

Code N.	Description	ISO	D	D1	D2	L	L1	L2 min	L2 max	V	M	G6,3 15000
252-11414	BT30-HC6-50,8	30	6	45	26	50,8	12	27	37	10	M5*0.8	•
252-11415	BT30-HC8-50,8	30	8	45	28	50,8	12,5	27	37	10	M6*1.0	•
252-11416	BT30-HC10-50,8	30	10	45	30	50,8	12,5	31	41	10	M8*1.0	•
252-11417	BT30-HC12-50,8	30	12	45	32	50,8	14	36	46	10	M8*1.0	•
252-11419	BT30-HC16-90	30	16	45	38	90	50	39	49	10	M8*1.0	•
252-11421	BT30-HC20-90	30	20	45	42	90	50	41	51	10	M8*1.0	•
252-11422	BT40-HC6-90	40	6	49,5	26	90	29	27	37	10	M5*0.8	•
252-11423	BT40-HC8-90	40	8	49,5	28	90	30	27	37	10	M6*1.0	•
252-11424	BT40-HC10-90	40	10	49,5	30	90	35	31	41	10	M8*1.0	•
252-11425	BT40-HC12-90	40	12	49,5	32	90	40	36	46	10	M10*1.0	•
252-11427	BT40-HC16-90	40	16	49,5	38	90	45	39	49	10	M12*1.0	•
252-11429	BT40-HC20-90	40	20	49,5	42	90	47	41	51	10	M16*1.0	•
252-11430	BT40-HC25-90	40	25	52	55	90	50	47	57	10	M16*1.0	•
252-11431	BT40-HC32-90	40	32	62	63	90	48	51	61	10	M16*1.0	•
252-11432	BT50-HC6-90	50	6	49,5	26	90	29	27	37	10	M5*0.8	•
252-11433	BT50-HC8-90	50	8	49,5	28	90	30	27	37	10	M6*1.0	•
252-11434	BT50-HC10-90	50	10	49,5	30	90	34	31	41	10	M8*1.0	•
252-11435	BT50-HC12-90	50	12	49,5	32	90	34	36	46	10	M10*1.0	•
252-11437	BT50-HC16-90	50	16	49,5	38	90	35	39	49	10	M12*1.0	•
252-11439	BT50-HC20-90	50	20	49,5	42	90	35	41	51	10	M16*1.0	•
252-11440	BT50-HC25-110	50	25	63	55	110	48	47	57	10	M16*1.0	•
252-11441	BT50-HC32-110	50	32	70	63	110	50	51	61	10	M16*1.0	•

High quality

Code N.	Description	ISO	D	D1	D2	L	L1	L2 min	L2 max	V	M	G6,3 15000
252-11443	BT40-G20CS-72.5	40	20	49,5	-	72,5	-	41	51	10	M16*1.0	•
252-11444	BT50-G32CS-90	50	32	72	-	90	-	51	61	10	M16*1.0	•

Zubehör
 Accessories
 Accessoires
 Accessori
 Принадлежности
 零件



Short Heavy Design

KRAFTSPANNFUTTER MANDRINS A FORT SERRAGE
 MILLING CHUCK MANDRINI A FORTE SERRAGGIO
 УСИЛЕННЫЕ ОПРАВКИ 铣夹头

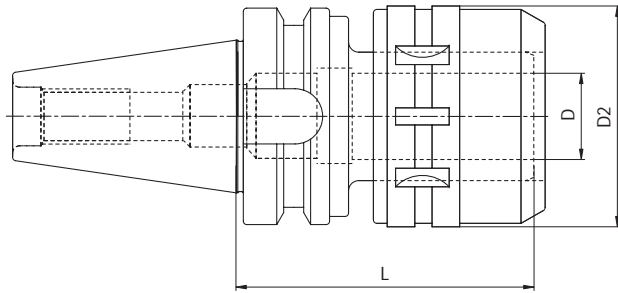

Code N.	Description	ISO	D	D2	L	G6,3 12000 RPM
214-01501	BT40H105C20	40	20	54	105	•
214-01502	BT40H105C32	40	32	72	105	•
214-01504	BT50H105C20	50	20	54	105	•
214-01505	BT50H105C32	50	32	72	105	•
214-01506	BT50H135C32	50	32	72	135	•

INKLUSIVE SPANNSCHLÜSSEL • SUPPLIED WITH WRENCH • ПОСТАВЛЯЕТСЯ С КЛЮЧОМ
 CLÉ INCLUDE • FORNITI CON CHIAVE INCLUSA • 供货时提供扳手

Zubehör
 Accessories
 Accessoires
 Accessori
 Принадлежности
 零件

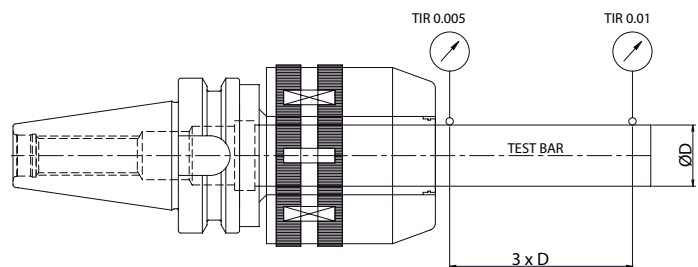

Milling chuck (diameter)	Specification (DIN)	Tolerance (Taper shank)	Run-out (3xD)	Clamping torque
C20	AT3	BT40 (0~ +0,003)	0~0,01	980M.m (100 Kgf.m)
C32		BT50 (0~ +0,004)		3430M.m (350 Kgf.m)

SPANNFUTTER FÜR EIN SCHRAUBFRÄSER
MILLING CUTTER ARBORS FOR SCREW-ON TYPE MILLING CUTTERS
ОПРАВКИ ДЛЯ ФРЕЗЕРНЫХ ГОЛОВOK

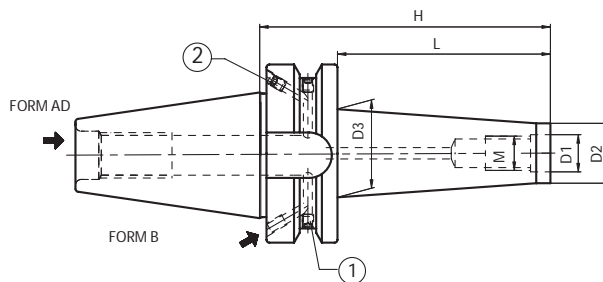

MANDRINS POUR FRAISER A VISSER
MANDRINI PER FRESE CON ATTACCO FILETTATO
螺纹连接型铣刀的铣刀杆



Code N.	Description	ISO	M	D1	D2	D3	H	L	G6,3 12000 RPM
217-81420	BT40H55M8	40	M8	8,5	13	15	55	28	•
217-81401	BT40H77M8	40	M8	8,5	13	23	77	50	•
217-81402	BT40H102M8	40	M8	8,5	13	23	102	75	•
217-81403	BT40H127M8	40	M8	8,5	13	25	127	100	•
217-81421	BT40H55M10	40	M10	10,5	18	20	55	28	•
217-81404	BT40H77M10	40	M10	10,5	18	23	77	50	•
217-81405	BT40H102M10	40	M10	10,5	18	28	102	75	•
217-81406	BT40H127M10	40	M10	10,5	18	32	127	100	•
217-81422	BT40H55M12	40	M12	12,5	21	24	55	28	•
217-81407	BT40H77M12	40	M12	12,5	21	24	77	50	•
217-81408	BT40H102M12	40	M12	12,5	21	31	102	75	•
217-81409	BT40H127M12	40	M12	12,5	21	33	127	100	•
217-81423	BT40H55M16	40	M16	17	29	32	55	28	•
217-81410	BT40H77M16	40	M16	17	29	34	77	50	•
217-81411	BT40H102M16	40	M16	17	29	34	102	75	•
217-81412	BT40H127M16	40	M16	17	29	36	127	100	•
217-81413	BT40H152M16	40	M16	17	29	40	152	125	•
217-81414	BT50H88M12	50	M12	12,5	21	24	88	50	•
217-81415	BT50H138M12	50	M12	12,5	21	33	138	100	•
217-81416	BT50H188M12	50	M12	12,5	21	40	188	150	•
217-81417	BT50H88M16	50	M16	17	29	34	88	50	•
217-81418	BT50H138M16	50	M16	17	29	36	138	100	•
217-81419	BT50H188M16	50	M16	17	29	42,5	188	150	•



Ersatzteile • Spare parts • Pièces détachées • Componenti • Запасные части • 零件

Tape	Screw	Quantity	Screw	Quantity
				
ISO 40	811-102002 M4X5	2	811-102002 M4X5	2
ISO 50	811-102002 M4X5	2	811-102010 M5X6	2

VERLÄNGERUNG FÜR EINSCHRAUBFRÄSER
EXTENSION FOR SCREW IN TYPE MILLS
КОРПУСА ДЛЯ ФРЕЗЕРНЫХ ГОЛОВОК

RALLONGES POUR FRAISES À VISSER
PROLUNGHE PER FRESE CON ATTACCO FILETTATO
铣刀内部螺丝加长

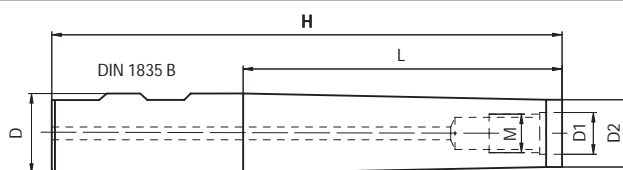

Code N.	Description	D	M	D1	D2	H	L
217-85201	D16H115M8	16	M8	8.5	12.8	115	60
217-85202	D16H160M8	16	M8	8.5	12.8	160	100
217-85203	D20H120M10	20	M10	10.5	17.8	120	60
217-85204	D20H160M10	20	M10	10.5	17.8	160	100
217-85205	D25H160M12	25	M12	12.5	20.8	160	100
217-85206	D32H160M16	32	M16	17	28.8	160	100

VERLÄNGERUNG FÜR EINSCHRAUBFRÄSER
EXTENSION FOR SCREW IN END MILLS
УДЛИНИТЕЛИ ДЛЯ ФРЕЗЕРНЫХ ГОЛОВОК

RALLONGES POUR FRAISES FILETEES
PROLUNGHE PER FRESE FILETTATE
铣刀内部螺丝加长

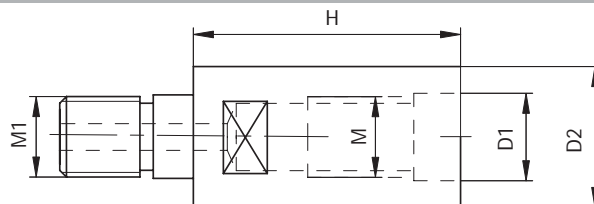

Code N.	Description	M	M1	D1	D2	H
217-85709	M8H30M8	M8	M8	8.5	12.8	30
217-85710	M10H35M10	M10	M10	10.5	17.8	35
217-85711	M12H40M12	M12	M12	12.5	20.8	40
217-85712	M16H40M16	M16	M16	17	28.8	40

ECKFRÄSER
SHOULDER MILLING CUTTERS
ФРЕЗЫ ДЛЯ ОБРАБОТКИ УСТУПОВ

FRAISES Á DRESSER
FRESE PER SPALLAMENTI
肩铣刀

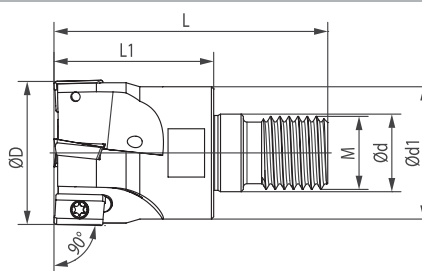

Code N.	Z	D	M	d	d1	L	L1	Insert	Screw	Wrench
454-01023	3	20	M10	10,5	18	50	30	APHT 1003.. APHX 1003.. APKT 1003..	KV25c	816-123002
454-01024	3	25	M12	12,5	21	57	35			
454-01025	4	25	M12	12,5	21	57	35			
454-01026	4	32	M16	17	29	60	35			
454-01027	5	32	M16	17	29	60	35			
454-01028	5	40	M16	17	37	60	35			

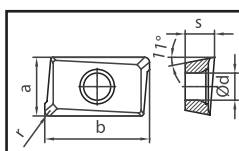

	a	b	s	d	r
APHT 1003.. APHX 1003.. APKT 1003..	6.7	10.8	3.55	2.8	0.5

Mit Luft- und Kühlbohrungen
With Coolant and air holes
с отверстием под охлаждение/воздух
Avec trou pour arrosage et air
Con fori per il passaggio dell'aria e del refrigerante

NC-BOHRFUTTER
UNIVERSAL DRILL CHUCKS
УНИВЕРСАЛЬНЫЕ СВЕРЛИЛЬНЫЕ ПАТРОНЫ

MANDRINS UNIVERSELS DE PERCAGE
MANDRINI PORTAPUNTE INTEGRALI
万能钻头

MAS 403BT ADB

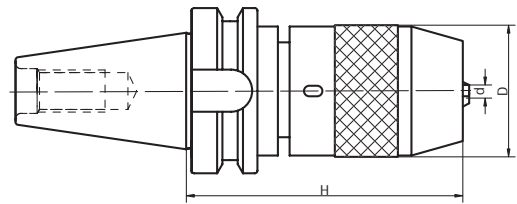

Code N.	Description	ISO	H	D	Clamping capacity	Wrench
252-11500	BT30H100R1-13	30	100	50	1-13	816-111024
252-11501	BT40H95R1-13	40	95	50	1-13	816-111024
252-11502	BT40H116R3-16	40	116	57	3-16	816-111025
252-11503	BT50H110R1-13	50	110	50	1-13	816-111024
252-11504	BT50H110R3-16	50	110	57	3-16	816-111025

RUNDLAUFGENAUIGKEIT 0.04 MM

Zur Erhöhung der Spannkraft werden diese Futter mit Spannschlüssel geliefert.
BEI LINKS LAUFENDEN BEARBEITUNGEN SIND DIESE
FUTTER NICHT ZU BENUTZEN.

RUNOUT ACCURACY 0.04 MM T.I.R.

Supplied with spanner wrench to allow the application
of supplementary gripping torque.
DO NOT USE IN REVOLUTION IN COUNTER-CLOCKWISE DIRECTION.

БИЕНИЕ 0,04 MM

Поставляется с ключом для более сильного зажима.
НЕ ВРАЩАТЬ ПРОТИВ ЧАСОВОЙ СРЕЛКИ!

PRECISION DE ROTATION 0.04 MM

Les mandrins sont fournis avec clé de blocage
pour augmenter la force de serrage.
NE PAS UTILISER DANS USINAGE AVEC ROTATION A GAUCHE

PRECISIONE DI ROTAZIONE 0.04 MM

Per incrementare la forza di serraggio i mandrini sono forniti
con chiave di bloccaggio.
NON DEVONO ESSERE USATI PER LAVORAZIONI
CON ROTAZIONE A SINISTRA.

径向跳动精度 0.04 MM T.I.R.

提供活动扳手，以便施加补充夹紧力。
不得用于逆时针方向旋转。

NC-BOHRFUTTER FÜR RECHTS-UND LINKSLAUF
NC DRILL CHUCKS FOR LEFT AND RIGHT ROTATION
СВЕРЛИЛЬНЫЕ ПАТРОНЫ С ВРАЩЕНИЕМ ПО- И ПРОТИВ
ЧАСОВОЙ СРЕЛКИ ДЛЯ СТАНКОВ С ЧПУ

MANDRIN DE PERCAGE CNC POUR ROTATION GAUCHE-DROITE
MANDRINI PORTAPUNTE INTEGRALI PER ROTAZIONE
DESTRA E SINISTRA
左右旋转 NC 钻头

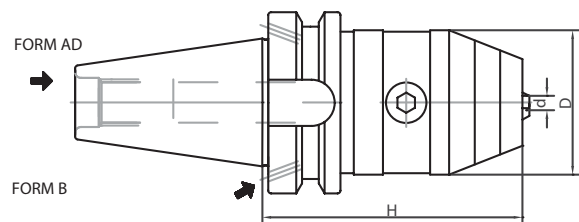

Code N.	Description	ISO	H	D	Clamping capacity	Wrench
252-11400	BT30H110R1-13X	30	110	50	1-13	816-152001
252-11410	BT40H98R1-13X	40	98	50	1-13	816-152001
252-11411	BT40H103R3-16X	40	103	50	3-16	816-152002
252-11412	BT50H109R1-13X	50	109	50	1-13	816-152001
252-11413	BT50H114R3-16X	50	114	50	3-16	816-152002

RUNDLAUFGENAUIGKEIT 0.03 MM

Sowohl für rechts- als auch links laufende Bearbeitungen geeignet,
mit Höchstgeschwindigkeit von 7000 u/min.

RUNOUT ACCURACY 0.03 MM T.I.R.

Suitable for right and left rotation up to 7000 rpm.

БИЕНИЕ 0,03 MM

Можно вращать по- и против часовой стрелки
со скоростью до 7000 об/мин.

PRECISION DE ROTATION 0.03 MM

Utilisables pour rotation droite et gauche,
avec maximale vélocité 7000 rpm

PRECISIONE DI ROTAZIONE 0.03 MM.

Adatti per rotazione sia destra che sinistra,
con velocità max di 7000 g/min.

径向跳动精度 0.03 MM T.I.R.

适用于最高转速达 7000 转/分钟的左右旋转

ROHLINGE MIT WEICHEM SCHAFT
BLANK TOOLHOLDER WITH SOFT SHANK
ЗАГОТОВКИ ДЛЯ ОПРАВОК НЕЗАКАЛЕННЫЕ

BARRES D'ALEPAGE SEMI-FINIES
MANDRINI SEMILAVORATI A STELO TENERO
带软柄的切断刀柄

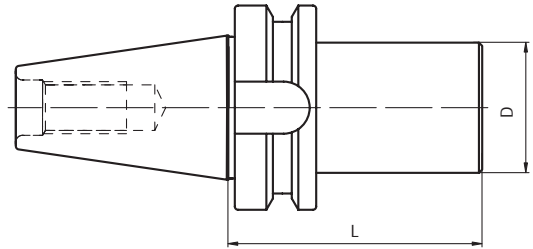

Code N.	Description	ISO	D	L
217-41502	BT40H160D40.5SM	40	40.5	160
217-41503	BT40H160D63.5SM	40	63.5	160
217-41504	BT40H250D63.5SM	40	63.5	250
217-41505	BT50H160D80SM	50	80	160
217-41506	BT50H200D80SM	50	80	200
217-41507	BT50H300D80SM	50	80	300

GEWINDESCHNEID-SCHNELLWECHSELFUTTER
MIT LÄNGENAUSGLEICH
TENSION AND COMPRESSION TAPPING HEAD
РЕЗЬБОНАРЕЗНЫЕ ПАТРОНЫ С КОМПЕНСАЦИЕЙ

MANDRINS DE TARAUDAGE A CHANGEMENT
RAPIDE A DOUBLE USAGE
MASCHIATORI A DOPPIA COMPENSAZIONE
张力和压缩丝攻头

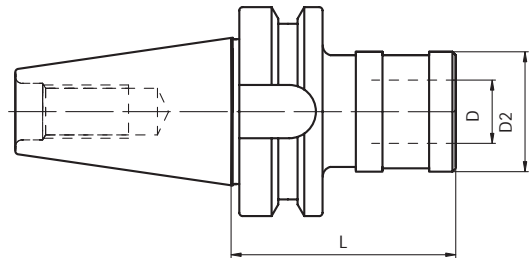

Code N.	Description	ISO	SIZE	Top range	PRESS.	EXT.	D	D2	L
M-3310	BT40H67GR1.DC	40	1	M3-M12	9	9	19	38	67
M-3410	BT40H93GR2.DC	40	2	M6-M20	15	15	31	53	93
M-3510	BT40H138GR3.DC	40	3	M14-M33	24	24	48	78	138
M-3320	BT50H81GR1.DC	50	1	M3-M12	9	9	19	38	80
M-3430	BT50H102GR2.DC	50	2	M6-M20	15	15	31	53	102
M-3530	BT50H135GR3.DC	50	3	M14-M33	24	24	48	78	135

GEWINDESCHNEID-SCHNELLWECHSELFUTTER
OHNE LÄNGENAUSGLEICH
SOLID TAPPING HEAD
РЕЗЬБОНАРЕЗНЫЕ ПАТРОНЫ БЕЗ КОМПЕНСАЦИИ

MANDRINS DE TARAUDAGE A CHANGEMENT
RAPIDE SANS COMPENSATION
MASCHIATORI RIGIDI SENZA COMPENSAZIONE
固体丝攻头

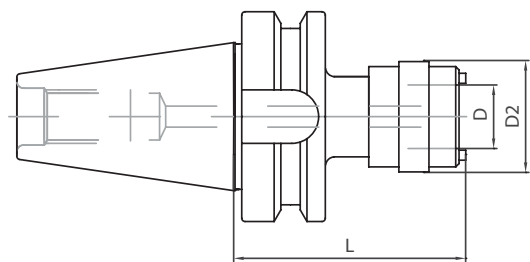

AD

Code N.	Description	ISO	SIZE	Top range	D	D2	L
M6010	BT40H67GR1.SC	40	1	M3-M12	19	33	67
M6020	BT40H90GR2.SC	40	2	M6-M20	31	50	90

Zubehör
Accessories
Accessoires
Accessori
Принадлежности
零件



GREIFER FÜR WERKZEUGMAGAZIN

Dank unserer intensiven und engen Zusammenarbeit mit den berühmtesten Maschinenherstellern Europas haben wir eine sehr gute Erfahrung auch in dem Bereich Magazinkassetten entwickelt. Gerne bieten wir Ihnen folgende Ausführungen: für ISO, HSK, und alle andere, nach Ihrem Wunsch.

CLAMPING FINGERS FOR TOOL MAGAZINES

Thanks to our constant and exhaustive co-operation with the most famous machine tool makers we developed a very good experience into the manufacturing of high precision clamping fingers for tool magazines. Our range includes clampers for the most popular attachments: ISO CONES, HSK, but of course we are open to any new version, according to the customer's drawing.

ЗАХВАТЫ ДЛЯ ИНСТРУМЕНТАЛЬНОГО МАГАЗИНА

Благодаря постоянному и тесному сотрудничеству с самыми известными производителями инструмента мы получили большой опыт в изготовлении высокоточных захватов для инструментальных магазинов. Линейка захватов включает в себя самые часто используемые модели: для конусов ISO и HSK. Разумеется, мы готовы изготовить специальный захват по чертежам заказчика.

PINCES DE LOGEMENT POUR LE MAGASIN DES MACHINES OUTILS

Grâce à notre constante et intensive collaboration avec les plus célèbres constructeurs des machine outils, nous avons développé une bonne expérience pour la production de pinces de logement pour le magasin des machine outils. Dans notre gamme il y a attachements: ISO, HSK et autres. Naturellement nous sommes ouverts à construire autres types de pinces suite aux différents plans du client.

PINZE ALLOGGIAMENTO PORTAUTENSILI PER MAGAZZINI MACCHINE UTENSILI

Grazie alla nostra costante ed intensa collaborazione con i più famosi costruttori di macchine utensili, abbiamo sviluppato una buona esperienza nella produzione di Pinze ad alta precisione per l'alloggiamento nei magazzini di macchine utensili.







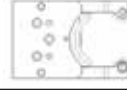

Nella nostra gamma sono presenti attacchi: ISO, HSK ed altri, e naturalmente siamo aperti ad altre versioni secondo disegno del cliente.

刀具库使用的夹具

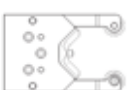
由于我公司长期与最为著名的机器工具制造商进行全面的合作，我公司已经积累了制造工具库使用的高精度夹具的丰富经验。我们的经营范围包括最为受欢迎的附件夹具：ISO 锥体、HSK，当然，我公司也欢迎由客户提供的图纸的任何新版本。



GREIFER / CLAMPING FINGERS / ЗАХВАТЫ / PINCES / PINZE / 夹具

		Codice/Code	Peso del mandrino / Toolholder 's weight			Lunghezza del mandrino (mm) Tool's length (mm)	Molla/Spring	
			Max. Load in vertical Pos .(kg)	Max. Load in upper Pos .(kg)	Max. Load in lower Pos .(kg)			
CAS-HSK63A		832-018030	14,6	7,8	4,1	250	SN 2540-16-76	A
		832-018470	21	11,2	5,9	250	SN 2560-16-76	B
CAS-HSK100A		832-018020	40	20,5	11	400	SDF600-20x102	A
		832-018480	80	50	27	400	SDF700-20x102	B
CAS-C6		832-007940	15,6	8,3	4,4	250	SN 2540-16-76	A
		832-018490	22,3	11,9	6,3	250	SN 2560-16-76	B
CAS-C8		832-018050	18,2	10,5	5,1	250	SDF600-16x89	A
		832-018500	29	16,7	8,2	250	SDF700-16x89	B
CAS-KM 63-2		832-007980	14,4	7,7	4	250	SN 2540-16-76	A
		832-018510	20,5	10,9	5,8	250	SN 2560-16-76	B
CAS-TC 40		832-018520	14,6	7,8	4,1	250	SN 2540-16-76	A
		832-018530	21	11,2	5,9	250	SN 2560-16-76	B
CAS-TC50		832-018360	25	13	7	400	SDF500-20x102	C
		832-018210	40	27	15	400	SDF600-20x102	A
CAS-BT 40		832-018540	14,6	7,8	4,1	250	SN 2540-16-76	A
		832-018550	21	11,2	5,9	250	SN 2560-16-76	B
CAS-BT 50		832-018370	25	13	7	400	SDF500-20x102	C
		832-018200	61	31	17	400	SDF600-20x102	A

A- Mittelfrucht Feder / Middle Strength Spring / Пружина средней жесткости / Ressort moyen force / Molla Forza Media / 中等强度的弹簧
 B- Verstärkte Feder / Stiffened Spring / Пружина повышенной жесткости / Ressort renforcé / Molla Rinforzata / 强化弹簧
 C- Normale Feder / Normal Spring / Пружина нормальной жесткости / Ressort normal / Molla Normale / 正常弹簧

GREIFER FÜR WERKZEUGMAGAZIN PINCES DE LOGEMENT POUR LE MAGASIN DES MACHINES OUTILS
 CLAMPING FINGERS PINZE PER MAGAZZINI UTENSILI
 ЗАХВАТЫ 夹具

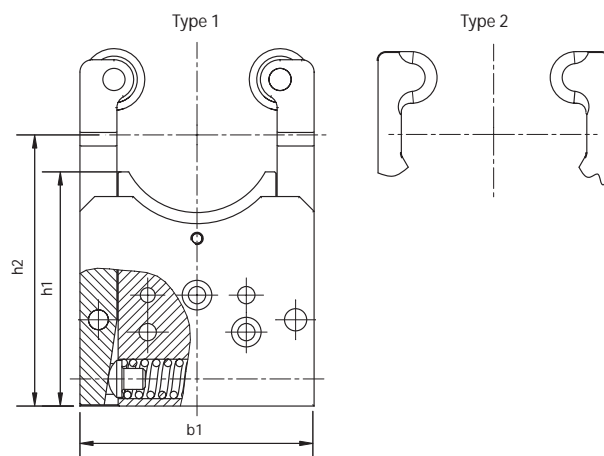

Code N.	Tool	b1	h1	h2	Type	Type spring
832-018030	HSK 63A	95	95	110	1	A
832-018470	HSK 63A	95	95	110	1	B
832-018020	HSK 100A	135	118	139	2	A
832-018480	HSK 100A	135	118	139	2	B
832-007940	CAPTO 6	95	91	110	1	A
832-018490	CAPTO 6	95	91	110	1	B
832-018050	CAPTO 8	105	85	110	1	A
832-018500	CAPTO 8	105	85	110	1	B
832-007980	KM 63	95	100	110	2	A
832-018510	KM 63	95	100	110	2	B
832-018520	TC 40	95	95	110	1	A
832-018530	TC 40	95	95	110	1	B
832-018360	TC 50	135	118	139	2	C
832-018210	TC 50	135	118	139	2	A
832-018540	BT 40	95	95	110	1	A
832-018550	BT 40	95	95	110	1	B
832-018370	BT 50	135	118	139	2	C
832-018200	BT 50	135	118	139	2	A

A- Mittelkraft Feder / Middle Strength Spring / Пружина средней жесткости / Ressort moyen force / Molla Forza Media / 中等强度的弹簧
 B- Verstärkte Feder / Stiffened Spring / Пружина повышенной жесткости / Ressort renforcé / Molla Rinforzata / 强化弹簧
 C- Normale Feder / Normal Spring / Пружина нормальной жесткости / Ressort normal / Molla Normale / 正常弹簧



KAMATEK



**ACCESSORIES
AND KIT**



PRÜFDORNE BARRES DE CONTROLE
 CONTROL PINS BARRE DI CONTROLLO
 КОНТРОЛЬНЫЕ ОПРАВКИ 控制销

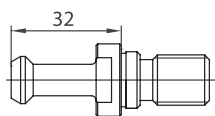

Special pull stud for MAS 403/BT40

DIN 69871 A
 DIN 2080
 MAS 403BT

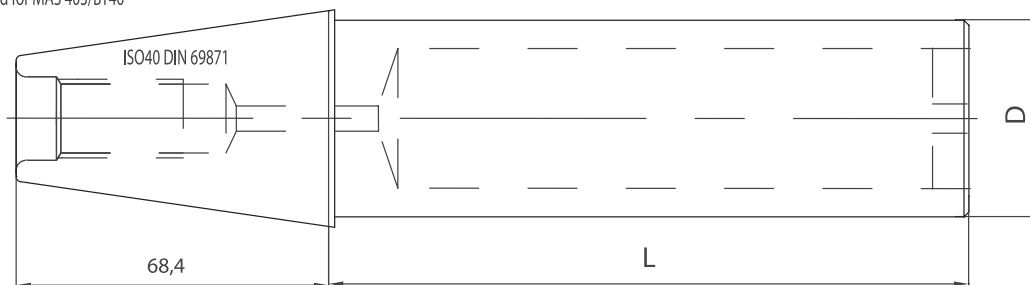

Code N.	Description	ISO	D	L
217-71201	TC40H300D40BC	40	40	300
217-71202	TC50H350D50BC	50	50	350

IM HOLZKASTEN UND MIT MESSPROTOKOLL GELIEFERT
 SUPPLIED IN WOODEN BOXES AND WITH TEST CERTIFICATE
 FOURNIES EN BOÎTES DE BOIS ET AVEC CERTIFICAT DE CONTROLE
 FORNITE IN CASSETTA DI LEGNO E CON CERTIFICATO DI COLLAUDO
 ПОСТАВЛЯЮТСЯ В ДЕРЕВЯННОМ ЯЩИКЕ С СЕРТИФИКАТОМ СООТВЕТСТВИЯ
 提供木箱，配备检测证书





ISO - PRÜFDORNE

TECHNISCHE DATEN

KEGELSCHAFTTOLERANZEN

IN KLASSE AT3 ANGEFERTIGT

PRÜFDORNTOLERANZEN

Durchmesser	Rundlaufgenauigkeit	Zylindrizität
+/-0.05	0.005	0.003

KONSTRUKTIONS DATEN

- aus Einsatzstahl zertifiziert und legiert angefertigt
- in der Einsatztiefe von 0,4-0,5 mm
- Gehärtet, angelassen, brüniert
- Härte HRC58 +/-2, Festigkeit 800-1000 N/ mm²
- Außgeschliffen
- 100% durch zertifizierte Meßinstrumente geprüft

Für DIN 2080 - DIN 69871 - MAS BT geeignet



ISO CONTROL PINS

TECHNICAL FEATURES

CONE'S TOLERANCE

ACCORDING TO THE CLASS AT3.

PIN'S TOLERANCE

Diameter	Runout accuracy	Cilindricity
+/-0.05	0.005	0.003

CONSTRUCTIVE FEATURES

- Manufactured with casehardening Steel
- Casehardened with depth 0,8 - 1mm
- Hardened - Tempered - Black oxidized
- Hardness HRC 58+/-2, Strength 800-100 N/mm²
- External grinding finish
- Tested 100% with certified measuring instruments

Suitable for DIN 2080 - DIN 69871 - MAS BT



КОНТРОЛЬНЫЕ ОПРАВКИ ISO

ТЕХНИЧЕСКОЕ ОПИСАНИЕ

ТОЧНОСТЬ КОНУСА

СООТВЕТСТВУЕТ КЛАССУ АТ3.

ТОЧНОСТЬ ЦИЛИНДРА

Diameter	Runout accuracy	Cilindricity
+/-0.05	0.005	0.003

КОНСТРУКТИВНЫЕ ОСОБЕННОСТИ

- Изготовлены из стали с последующей цементацией
- Цементация на глубину 0,8 - 1 мм
- Оправки подвергнуты закалке и отпуску.
Защитно-декоративное покрытие черного цвета.
- Твердость 58+/-2 HRC, прочность 800-1000 Н/мм²
- Шлифованная внешняя поверхность
- Каждая оправка испытана на сертифицированном оборудовании

Подходит для DIN 2080 - DIN 69871 - MAS BT



BARRES DE CONTROLE ISO

DONNEES TECHNIQUES

TOLERANCE DU CONE

FABRIQUEES EN CLASSE AT3

TOLERANCE DE LA BARRE

Diamètre	Coaxialité	Cylindricité
+/-0.05	0.005	0.003

ELEMENTS DE CÔNSTRUCTION

- Produites en acier cémenté certifié et allié au Ni.Cr.Mo.
- Cémentées avec profondeur 0,8 - 1mm
- Trempées - Revenues - Brunies
- Dureté HRC 58 +- 2 résistance 800-1000 N/ mm2
- Finition de rectification extérieure
- Contrôlées à 100% avec des instruments de mesure certifiés

Utilisable pour DIN 2080 - DIN 69871 - MAS BT



BARRE DI CONTROLLO ISO

DATI TECNICI

TOLLERANZA DEL CONO

PRODOTTI IN CLASSE AT3.

TOLLERANZE DELLA BARRA

Diametro	Coassialità	Cilindricità
+/-0.05	0.005	0.003

DATI COSTRUTTIVI

- Costruite in acciaio da cementazione certificato e legato
- Cementate con profondità 0,4 - 0,5 mm
- Temprate-rinvenute-brunite
- Durezza HRC 58 +- 2 resistenza 800-1000 N/ mm2
- Finitura di rettifica esterna
- Collaudate 100% con strumenti di misura certificati

Utilizzabile per DIN 2080 - DIN 69871 - MAS BT



插销 ISO 控制

技术特点

锥体的误差

符合 AT3 级别。

插销的误差

Diameter	Runout accuracy	Cilindricity
+/-0.05	0.005	0.003

结构特点

- 用表面硬化钢材制造。
- 硬化深度达 0,8 - 1 毫米。
- 经过硬化及回火处理。黑色氧化。
- 硬度达 HRC 58+-2, 强度达 800-1000 N / 平方毫米。
- 外部表面打磨处理。
- 100% 使用经过认证的测量仪器检测。

适用于 DIN 2080 - DIN 69871 - MAS BT。

POSITIONSPRÜFUNG DES WERKZEUGWECHSLERS CONTROLE DU POSITIONNEMENT DU BRAS CHANGEUR D'OUTIL
 POSITIONING CONTROL OF THE TOOL CHANGER ARM CONTROLLO POSIZIONE BRACETTO CAMBIO UTENSILE
 ПРИБОР ДЛЯ КОНТРОЛЯ ПОЗИЦИОНИРОВАНИЯ ЗАХВАТЧИКА ДЛЯ СМЕНЫ ИНСТРУМЕНТА

Code	Cone
KIT.PRUEFD-TC40	TC40
KIT.PRUEFD-TC50	TC50
KIT.PRUEFD-BT40	BT40
KIT.PRUEFD-BT50	BT50
KIT.PRUEFD-H40A	HSK40A
KIT.PRUEFD-H50A	HSK50A
KIT.PRUEFD-H63A	HSK63A
KIT.PRUEFD-H100A	HSK100A
KIT.PRUEFD-C4	CAPTO4
KIT.PRUEFD-C5	CAPTO5
KIT.PRUEFD-C6	CAPTO6

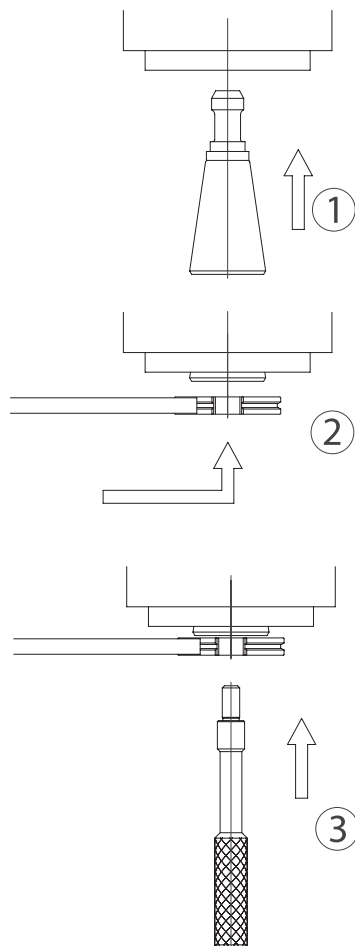
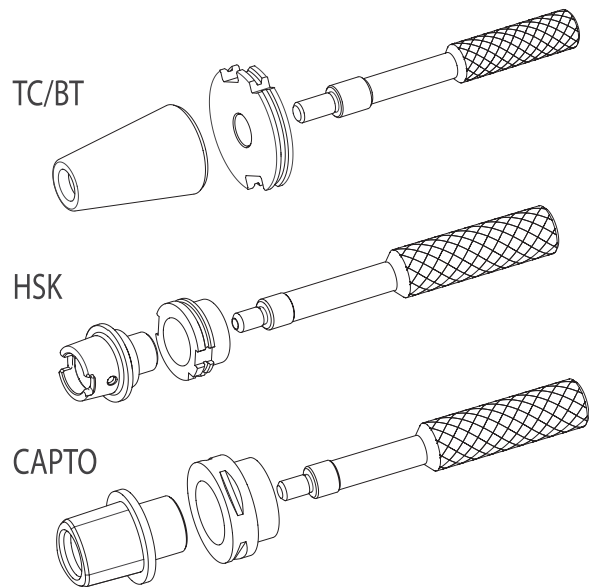

- 1 Nach der Montage der üblichen Anzugsbolzen spannen Sie die Aufnahme manuell in die Spindel.
- 2 Spannen Sie den Flansch in den Werkzeugwechsler Arm und gehen Sie näher an der Spindel.
- 3 Nach der Positionierung versuchen Sie, die Doppel-Durchmesser-Prüfdorne zwischen den beiden Stücken einzusetzen. Stellen Sie den Arm entsprechend ein, bis Sie die perfekte Rundlaufgenauigkeit bekommen, wenn die Dorne in die Bohrungen des Flansches und der Aufnahme ohne Übermaß hineingeht.



- 1 After assembling the usual pull stud, insert the cone into the spindle manually.
- 2 Set up the flange into the tool changer arm and go closer to the spindle.
- 3 After positioning, try to insert the double-diameter control pin between the two pieces. Adjust the arm accordingly until you get the perfect coaxiality so that the control bar enters the flange and the cone holes with no interferences.



- 1 Après le montage de la tirette, insérez manuellement le cône dans le mandrin de la machine.
- 2 Montez la bride dans le bras changeur d'outil et rapprochez de la machine.
- 3 Après le positionnement, essayez d'insérer la barre de contrôle à double diamètre entre les deux pièces. Ajustez le bras en conséquence jusqu'à ce que vous obtenez la coaxialité parfaite quand la barre entre sans interférences dans les trous de la bride et du cône.



- 1 Inserire manualmente il cono nel mandrino della macchina, dopo aver montato il codolo normalmente usato.
- 2 Montare la flangia nel braccetto cambia utensile ed avvicinarsi al naso macchina.
- 3 Una volta in posizione provare ad inserire la spina di controllo a doppio diametro tra i 2 pezzi. Regolare di conseguenza il braccetto cambia utensile fino a raggiungere la perfetta coassialità quando la spina entra senza interferenze nei fori della flangia e del cono.

SPANNFUTTER MIT ZYLINDERSCHAFT MIT MINI SPANNMUTTER
CYLINDRICAL COLLET CHUCKS WITH MINI NUT
ЦАНГОВЫЕ ПАТРОНЫ С ЦИЛИНДРИЧЕСКИМ
ХВОСТОВИКОМ С МИНИ-ГАЙКОЙ

PORTE PINCES QUEUE CYLINDRIQUE AVEC ECROU MINI
PORTAPINZA GAMBO CILINDRICO CON GHIERA MINI
帶微型螺母的圆柱式弹簧夹头

DIN 6499

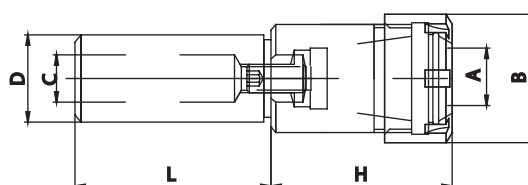

Code N.	Description	Dh6	L	H	B	C	Clamping capacity	Nut	Description
264-35114	D5L45ER8M	5	45	24	12	-	1÷5	812-203011	ER8M
214-35101	D6L45ER8M	6	45	24	12	-	1÷5	812-203011	ER8M
214-35139	D6L45ER11M	6	45	25	16	-	1÷7	812-203012	ER11M
264-35115	D7L45ER11M	7	45	25	16	-	1÷7	812-203012	ER11M
214-35102	D8L55ER8M	8	55	24	12	-	1÷5	812-203011	ER8M
214-35108	D8L80ER8M	8	80	24	12	-	1÷5	812-203011	ER8M
214-35714	D8L100ER8M	8	100	24	12	-	1÷5	812-203011	ER8M
214-35715	D8L130ER8M	8	130	24	12	-	1÷5	812-203011	ER8M
214-35109	D8L55ER11M	8	55	25	16	-	1÷7	812-203012	ER11M
264-35116	D8L100ER11M	8	100	25	16	-	1÷7	812-203012	ER11M
214-35716	D8L55ER16M	8	55	37	22	-	1÷10	812-203013	ER16M
214-35717	D8L100ER16M	8	100	37	22	-	1÷10	812-203013	ER16M
264-35117	D10L55ER8M	10	55	24	12	5	1÷5	812-203011	ER8M
214-35718	D10L80ER8M	10	80	24	12	5	1÷5	812-203011	ER8M
264-35118	D10L100ER8M	10	100	24	12	5	1÷5	812-203011	ER8M
214-35719	D10L130ER8M	10	130	24	12	5	1÷5	812-203011	ER8M
214-35110	D10L55ER11M	10	55	25	16	5	1÷7	812-203012	ER11M
214-35720	D10L80ER11M	10	80	25	16	5	1÷7	812-203012	ER11M
264-35119	D10L100ER11M	10	100	25	16	5	1÷7	812-203012	ER11M
214-35721	D10L130ER11M	10	130	25	16	5	1÷7	812-203012	ER11M
214-35113	D10L60ER16M	10	60	37	22	5	1÷10	812-203013	ER16M
214-35722	D10L80ER16M	10	80	37	22	5	1÷10	812-203013	ER16M
264-35120	D10L100ER16M	10	100	37	22	5	1÷10	812-203013	ER16M
214-35723	D12L55ER8M	12	55	15	12	5	1÷5	812-203011	ER8M
214-35724	D12L70ER8M	12	70	15	12	5	1÷5	812-203011	ER8M
214-35140	D12L100ER8M	12	100	15	12	5	1÷5	812-203011	ER8M
264-35121	D12L140ER8M	12	140	15	12	5	1÷5	812-203011	ER8M
264-35122	D12L55ER11M	12	55	25	16	7	1÷7	812-203012	ER11M
214-35141	D12L70ER11M	12	70	25	16	7	1÷7	812-203012	ER11M
214-35142	D12L100ER11M	12	100	25	16	7	1÷7	812-203012	ER11M
214-35143	D12L140ER11M	12	140	25	16	7	1÷7	812-203012	ER11M
264-35123	D12L55ER16M	12	55	37	22	7	1÷10	812-203013	ER16M
214-35114	D12L80ER16M	12	80	37	22	7	1÷10	812-203013	ER16M
264-35124	D12L120ER16M	12	120	37	22	7	1÷10	812-203013	ER16M
264-35125	D15L100ER20M	15	100	41	28	9	1÷13	812-203014	ER20M
264-35126	D16L40ER11M	16	40	22	16	7	1÷7	812-203012	ER11M
214-35725	D16L60ER11M	16	60	22	16	7	1÷7	812-203012	ER11M
264-35127	D16L80ER11M	16	80	22	16	7	1÷7	812-203012	ER11M
264-35128	D16L100ER11M	16	100	22	16	7	1÷7	812-203012	ER11M
264-35129	D16L130ER11M	16	130	22	16	7	1÷7	812-203012	ER11M
264-35130	D16L160ER11M	16	160	22	16	7	1÷7	812-203012	ER11M
214-35726	D16L200ER11M	16	200	22	16	7	1÷7	812-203012	ER11M
264-35131	D16L35ER16M	16	35	37	22	7	1÷10	812-203013	ER16M
264-35132	D16L60ER16M	16	60	37	22	7	1÷10	812-203013	ER16M
214-35115	D16L80ER16M	16	80	37	22	7	1÷10	812-203013	ER16M
214-35145	D16L100ER16M	16	100	37	22	7	1÷10	812-203013	ER16M
214-35146	D16L130ER16M	16	130	37	22	7	1÷10	812-203013	ER16M
214-35147	D16L160ER16M	16	160	37	22	7	1÷10	812-203013	ER16M
214-35727	D16L200ER16M	16	200	37	22	7	1÷10	812-203013	ER16M
264-35133	D16L55ER20M	16	55	40	28	9	1÷13	812-203014	ER20M
214-35148	D16L100ER20M	16	100	40	28	9	1÷13	812-203014	ER20M
264-35134	D16L130ER20M	16	130	40	28	9	1÷13	812-203014	ER20M
264-35135	D16L160ER20M	16	160	40	28	9	1÷13	812-203014	ER20M

D5÷D16 Zylinderschaft • Shank without flat • Queue cylindrique • Stelo senza piano • Хвостовик без лыски • 柄不带平面

SPANNFUTTER MIT ZYLINDERSCHAFT MIT MINI SPANNMUTTER
CYLINDRICAL COLLET CHUCKS WITH MINI NUT
ЦАНГОВЫЕ ПАТРОНЫ С ЦИЛИНДРИЧЕСКИМ
ХВОСТОВИКОМ С МИНИ-ГАЙКОЙ

PORTE PINCES QUEUE CYLINDRIQUE AVEC ECROU MINI
PORTAPINZA GAMBO CILINDRICO CON GHIERA MINI
带微型螺母的圆柱式弹簧夹头

DIN 6499

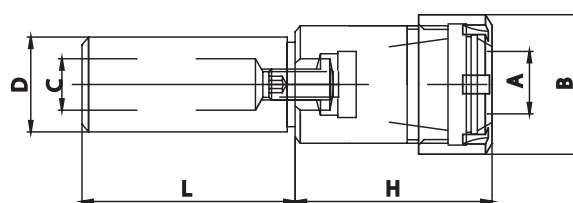

Code N.	Description	Dh6	L	H	B	C	Clamping capacity	Nut	Description
214-35728	D19,05L50ER11M	19,05	50	18	16	7	1÷7	812-203012	ER11M
214-35729	D19,05L100ER11M	19,05	100	18	16	7	1÷7	812-203012	ER11M
214-35730	D19,05L60ER16M	19,05	60	30	22	11	1÷10	812-203013	ER16M
214-35731	D19,05L100ER16M	19,05	100	30	22	11	1÷10	812-203013	ER16M
214-35732	D19,05L50ER20M	19,05	50	37	28	11	1÷13	812-203014	ER20M
214-35733	D19,05L100ER20M	19,05	100	37	28	11	1÷13	812-203014	ER20M
214-35734	D19,05L50ER25M	19,05	50	46	35	11	1÷16	812-203015	ER25M
214-35735	D19,05L100ER25M	19,05	100	46	35	11	1÷16	812-203015	ER25M
264-35136	D20L50ER11M	20	50	22	16	7	1÷7	812-203012	ER11M
264-35137	D20L100ER11M	20	100	22	16	7	1÷7	812-203012	ER11M
214-35736	D20L130ER11M	20	130	22	16	7	1÷7	812-203012	ER11M
214-35737	D20L160ER11M	20	160	22	16	7	1÷7	812-203012	ER11M
214-35738	D20L200ER11M	20	200	22	16	7	1÷7	812-203012	ER11M
214-35149	D20L60ER16M	20	60	30	22	11	1÷10	812-203013	ER16M
214-35150	D20L100ER16M	20	100	30	22	11	1÷10	812-203013	ER16M
264-35138	D20L130ER16M	20	130	30	22	11	1÷10	812-203013	ER16M
214-35151	D20L160ER16M	20	160	30	22	11	1÷10	812-203013	ER16M
264-35139	D20L200ER16M	20	200	30	22	11	1÷10	812-203013	ER16M
214-35739	D20L250ER16M	20	250	30	22	11	1÷10	812-203013	ER16M
264-35140	D20L46ER20M	20	46	37	28	11	1÷13	812-203014	ER20M
214-35152	D20L60ER20M	20	60	37	28	11	1÷13	812-203014	ER20M
214-35111	D20L100ER20M	20	100	37	28	11	1÷13	812-203014	ER20M
214-35153	D20L130ER20M	20	130	37	28	11	1÷13	812-203014	ER20M
214-35154	D20L160ER20M	20	160	37	28	11	1÷13	812-203014	ER20M
264-35141	D20L200ER20M	20	200	37	28	11	1÷13	812-203014	ER20M
214-35740	D20L250ER20M	20	250	37	28	11	1÷13	812-203014	ER20M
264-35142	D20L46ER25M	20	46	46	35	11	1÷16	812-203015	ER25M
214-35155	D20L60ER25M	20	60	46	35	11	1÷16	812-203015	ER25M
214-35116	D20L100ER25M	20	100	46	35	11	1÷16	812-203015	ER25M
214-35156	D20L130ER25M	20	130	46	35	11	1÷16	812-203015	ER25M
214-35741	D20L160ER25M	20	160	46	35	11	1÷16	812-203015	ER25M
214-35742	D22L80ER16M	22	80	27	22	11	1÷10	812-203013	ER16M
214-35743	D22L80ER20M	22	80	30	28	11	1÷13	812-203014	ER20M
264-35143	D25L100ER11M	25	100	18	16	7	1÷7	812-203012	ER11M
214-35744	D25L130ER11M	25	130	18	16	7	1÷7	812-203012	ER11M
214-35745	D25L160ER11M	25	160	18	16	7	1÷7	812-203012	ER11M
264-35144	D25L60ER16M	25	60	27	22	11	1÷10	812-203013	ER16M
214-35157	D25L100ER16M	25	100	27	22	11	1÷10	812-203013	ER16M
264-35145	D25L130ER16M	25	130	27	22	11	1÷10	812-203013	ER16M
264-35146	D25L160ER16M	25	160	27	22	11	1÷10	812-203013	ER16M
214-35746	D25L200ER16M	25	200	27	22	11	1÷10	812-203013	ER16M
214-35158	D25L60ER20M	25	60	28	28	13	1÷13	812-203014	ER20M
214-35159	D25L100ER20M	25	100	28	28	13	1÷13	812-203014	ER20M
264-35147	D25L130ER20M	25	130	28	28	13	1÷13	812-203014	ER20M
214-35160	D25L160ER20M	25	160	28	28	13	1÷13	812-203014	ER20M
214-35747	D25L200ER20M	25	200	28	28	13	1÷13	812-203014	ER20M
264-35148	D25L50ER25M	25	50	32	35	13	1÷16	812-203015	ER25M
214-35161	D25L70ER25M	25	70	32	35	13	1÷16	812-203015	ER25M
264-35149	D25L100ER25M	25	100	32	35	13	1÷16	812-203015	ER25M
214-35162	D25L130ER25M	25	130	32	35	13	1÷16	812-203015	ER25M
264-35150	D25L160ER25M	25	160	32	35	13	1÷16	812-203015	ER25M
214-35748	D25L200ER25M	25	200	32	35	13	1÷16	812-203015	ER25M
214-35749	D25,4L60ER16M	25,4	60	27	22	11	1÷10	812-203013	ER16M
214-35750	D25,4L100ER16M	25,4	100	27	22	11	1÷10	812-203013	ER16M
214-35751	D25,4L140ER16M	25,4	140	27	22	11	1÷10	812-203013	ER16M
214-35752	D25,4L70ER20M	25,4	70	28	28	13	1÷13	812-203014	ER20M
214-35753	D25,4L100ER20M	25,4	100	28	28	13	1÷13	812-203014	ER20M
214-35754	D25,4L140ER20M	25,4	140	28	28	13	1÷13	812-203014	ER20M
214-35755	D25,4L70ER25M	25,4	70	32	35	13	1÷16	812-203015	ER25M
214-35756	D25,4L100ER25M	25,4	100	32	35	13	1÷16	812-203015	ER25M
214-35757	D25,4L140ER25M	25,4	140	32	35	13	1÷16	812-203015	ER25M
264-35151	D32L90ER16M	32	90	30	22	11	1÷10	812-203013	ER16M
214-35163	D32L90ER20M	32	90	27	28	13	1÷13	812-203014	ER20M

D19,05÷D32 Zylinderschaft mit Fläche • Shank with flat • Queue cylindrique avec plat • Stelo con piano • Хвостовик с лыской • 柄带平面

SPANNFUTTER MIT ZYLINDERSCHAFT MIT STANDARD SPANNMUTTER
CYLINDRICAL COLLET CHUCKS WITH STANDARD NUT
ЦАНГОВЫЕ ПАТРОНЫ С ЦИЛИНДРИЧЕСКИМ
ХВОСТОВИКОМ СО СТАНДАРТНОЙ ГАЙКОЙ

PORTE PINCES QUEUE CYLINDRIQUE AVEC ECROU STANDARD
PORTAPINZA GAMBO CILINDRICO CON GHIERA STANDARD
带标准螺母的圆柱式弹簧夹头

DIN 6499

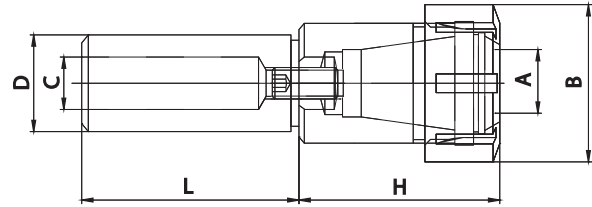

Code N.	Description	Dh6	L	H	B	C	Clamping capacity	Nut	Description
264-35152	D14L60ER16	14	60	36	32	7	1÷10	812-203005	ER16
214-35144	D16L60ER16	16	60	36	32	7	1÷10	812-203005	ER16
214-35758	D16L80ER16	16	80	36	32	7	1÷10	812-203005	ER16
214-35126	D16L100ER16	16	100	36	32	7	1÷10	812-203005	ER16
214-35759	D16L130ER16	16	130	36	32	7	1÷10	812-203005	ER16
214-35760	D16L160ER16	16	160	36	32	7	1÷10	812-203005	ER16
214-35761	D16L200ER16	16	200	36	32	7	1÷10	812-203005	ER16
264-35153	D16L60ER20	16	60	40	35	9	1÷13	812-203006	ER20
264-35154	D16L35ER25	16	35	46	42	9	1÷16	812-203001	ER25
264-35155	D16L70ER25	16	70	46	42	9	1÷16	812-203001	ER25
214-35762	D19,05L50ER16	19,05	50	32	32	11	1÷10	812-203005	ER16
214-35763	D19,05L100ER16	19,05	100	32	32	11	1÷10	812-203005	ER16
214-35764	D19,05L50ER20	19,05	50	36	35	11	1÷13	812-203006	ER20
214-35765	D19,05L100ER20	19,05	100	36	35	11	1÷13	812-203006	ER20
214-35766	D19,05L50ER25	19,05	50	46	42	11	1÷16	812-203001	ER25
214-35767	D19,05L100ER25	19,05	100	46	42	11	1÷16	812-203001	ER25
214-35768	D19,05L50ER32	19,05	50	54	50	13	2÷20	812-203002	ER32
214-35769	D19,05L100ER32	19,05	100	54	50	13	2÷20	812-203002	ER32
264-35156	D20L50ER16	20	50	31	32	11	1÷10	812-203005	ER16
214-35127	D20L100ER16	20	100	31	32	11	1÷10	812-203005	ER16
214-35770	D20L130ER16	20	130	31	32	11	1÷10	812-203005	ER16
264-35157	D20L160ER16	20	160	31	32	11	1÷10	812-203005	ER16
214-35771	D20L200ER16	20	200	31	32	11	1÷10	812-203005	ER16
264-35158	D20L46ER20	20	46	36	35	11	1÷13	812-203006	ER20
264-35159	D20L60ER20	20	60	36	35	11	1÷13	812-203006	ER20
264-35160	D20L100ER20	20	100	36	35	11	1÷13	812-203006	ER20
214-35772	D20L130ER20	20	130	36	35	11	1÷13	812-203006	ER20
214-35773	D20L160ER20	20	160	36	35	11	1÷13	812-203006	ER20
214-35774	D20L200ER20	20	200	36	35	11	1÷13	812-203006	ER20
214-35119	D20L50ER25	20	50	46	42	11	1÷16	812-203001	ER25
214-35128	D20L100ER25	20	100	46	42	11	1÷16	812-203001	ER25
264-35161	D20L130ER25	20	130	46	42	11	1÷16	812-203001	ER25
264-35162	D20L160ER25	20	160	46	42	11	1÷16	812-203001	ER25
264-35163	D20L50ER32	20	50	54	50	13	2÷20	812-203002	ER32
214-35129	D20L100ER32	20	100	54	50	13	2÷20	812-203002	ER32
264-35164	D20L130ER32	20	130	54	50	13	2÷20	812-203002	ER32
264-35165	D20L160ER32	20	160	54	50	13	2÷20	812-203002	ER32
264-35166	D22L80ER16	22	80	26	32	11	1÷10	812-203005	ER16
264-35167	D22L80ER20	22	80	36	35	11	1÷13	812-203006	ER20
264-35168	D22L50ER25	22	50	42	42	13	1÷16	812-203001	ER25
264-35169	D22L80ER25	22	80	42	42	13	1÷16	812-203001	ER25
264-35170	D22L50ER32	22	50	53	50	13	2÷20	812-203002	ER32
214-35775	D25L60ER16	25	60	27	32	11	1÷10	812-203005	ER16
214-35776	D25L100ER16	25	100	27	32	11	1÷10	812-203005	ER16
214-35777	D25L130ER16	25	130	27	32	11	1÷10	812-203005	ER16
214-35778	D25L160ER16	25	160	27	32	11	1÷10	812-203005	ER16
214-35779	D25L200ER16	25	200	27	32	11	1÷10	812-203005	ER16
264-35171	D25L60ER20	25	60	28	35	13	1÷13	812-203006	ER20
264-35172	D25L100ER20	25	100	28	35	13	1÷13	812-203006	ER20
214-35780	D25L130ER20	25	130	28	35	13	1÷13	812-203006	ER20
214-35781	D25L160ER20	25	160	28	35	13	1÷13	812-203006	ER20
214-35120	D25L50ER25	25	50	32	42	13	1÷16	812-203001	ER25
214-35782	D25L70ER25	25	70	32	42	13	1÷16	812-203001	ER25
214-35130	D25L100ER25	25	100	32	42	13	1÷16	812-203001	ER25
264-35173	D25L130ER25	25	130	32	42	13	1÷16	812-203001	ER25
264-35174	D25L160ER25	25	160	32	42	13	1÷16	812-203001	ER25

D14÷D16 Zylinderschaft • Shank without flat • Queue cylindrique • Stelo senza piano • Хвостовик без лыски • 柄不带平面

D19,05÷D25 Zylinderschaft mit Fläche • Shank with flat • Queue cylindrique avec plat • Stelo con piano • Хвостовик с лыской • 柄带平面

SPANNFUTTER MIT ZYLINDERSCHAFT UND STANDARD SPANNMUTTER
CYLINDRICAL COLLET CHUCKS WITH STANDARD NUT
ЦАНГОВЫЕ ПАТРОНЫ С ЦИЛИНДРИЧЕСКИМ
ХВОСТОВИКОМ СО СТАНДАРТНОЙ ГАЙКОЙ

PORTE PINCES QUEUE CYLINDRIQUE AVEC ECRU STANDARD
PORTAPINZA GAMBO CILINDRICO CON GHIERA STANDARD
带标准螺母的圆柱式弹簧夹头

DIN 6499

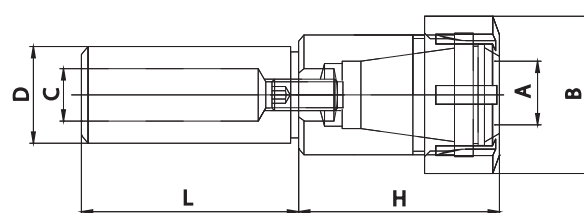

Code N.	Description	Dh6	L	H	B	C	Clamping capacity	Nut	Description
264-35175	D25L50ER32	25	50	54	50	13	2÷20	812-203002	ER32
264-35176	D25L70ER32	25	70	54	50	13	2÷20	812-203002	ER32
214-35131	D25L100ER32	25	100	54	50	13	2÷20	812-203002	ER32
264-35177	D25L130ER32	25	130	54	50	13	2÷20	812-203002	ER32
264-35178	D25L160ER32	25	160	54	50	13	2÷20	812-203002	ER32
264-35179	D25L50ER40	25	50	60	63	13	3÷30	812-203003	ER40
264-35180	D25L100ER40	25	100	60	63	13	3÷30	812-203003	ER40
264-35726	D25,4L60ER16	25,4	60	27	32	11	1÷10	812-203005	ER16
264-35727	D25,4L100ER16	25,4	100	27	32	11	1÷10	812-203005	ER16
264-35728	D25,4L60ER20	25,4	60	28	35	13	1÷13	812-203006	ER20
264-35729	D25,4L100ER20	25,4	100	28	35	13	1÷13	812-203006	ER20
264-35730	D25,4L50ER25	25,4	50	32	42	13	1÷16	812-203001	ER25
264-35731	D25,4L70ER25	25,4	70	32	42	13	1÷16	812-203001	ER25
264-35732	D25,4L100ER25	25,4	100	32	42	13	1÷16	812-203001	ER25
264-35733	D25,4L50ER32	25,4	50	54	50	13	2÷20	812-203002	ER32
264-35734	D25,4L70ER32	25,4	70	54	50	13	2÷20	812-203002	ER32
264-35735	D25,4L100ER32	25,4	100	54	50	13	2÷20	812-203002	ER32
264-35736	D25,4L50ER40	25,4	50	60	63	13	3÷30	812-203003	ER40
264-35181	D30L50ER25	30	50	45	42	19	1÷16	812-203001	ER25
264-35182	D30L50ER32	30	50	53	50	23	2÷20	812-203002	ER32
264-35183	D30L50ER40	30	50	60	63	23	3÷30	812-203003	ER40
264-35737	D31,75L50ER32	31,75	50	44	50	23	2÷20	812-203002	ER32
264-35738	D31,75L50ER40	31,75	50	60	63	23	3÷30	812-203003	ER40
264-35739	D32L100ER16	32	100	27	32	11	1÷10	812-203005	ER16
264-35740	D32L150ER16	32	150	27	32	11	1÷10	812-203005	ER16
264-35741	D32L100ER20	32	100	28	35	13	1÷13	812-203006	ER20
264-35742	D32L150ER20	32	150	28	35	13	1÷13	812-203006	ER20
214-35132	D32L70ER25	32	70	28	42	19	1÷16	812-203001	ER25
264-35743	D32L100ER25	32	100	28	42	19	1÷16	812-203001	ER25
264-35184	D32L120ER25	32	120	28	42	19	1÷16	812-203001	ER25
264-35744	D32L150ER25	32	150	28	42	19	1÷16	812-203001	ER25
264-35185	D32L50ER32	32	50	38	50	23	2÷20	812-203002	ER32
214-35117	D32L70ER32	32	70	38	50	23	2÷20	812-203002	ER32
264-35186	D32L100ER32	32	100	38	50	23	2÷20	812-203002	ER32
214-35133	D32L120ER32	32	120	38	50	23	2÷20	812-203002	ER32
214-35134	D32L150ER32	32	150	38	50	23	2÷20	812-203002	ER32
264-35187	D32L50ER40	32	50	60	63	23	3÷30	812-203003	ER40
264-35188	D32L70ER40	32	70	60	63	23	3÷30	812-203003	ER40
264-35745	D32L100ER40	32	100	60	63	23	3÷30	812-203003	ER40
264-35746	D32L130ER40	32	130	60	63	23	3÷30	812-203003	ER40
264-35747	D35L80ER32	35	80	38	50	23	2÷20	812-203002	ER32
264-35189	D40L70ER25	40	70	42	42	19	1÷16	812-203001	ER25
214-35135	D40L120ER25	40	120	42	42	19	1÷16	812-203001	ER25
214-35136	D40L70ER32	40	70	30	50	23	2÷20	812-203002	ER32
264-35748	D40L100ER32	40	100	30	50	23	2÷20	812-203002	ER32
214-35137	D40L130ER32	40	130	30	50	23	2÷20	812-203002	ER32
264-35749	D40L160ER32	40	160	30	50	23	2÷20	812-203002	ER32
264-35190	D40L50ER40	40	50	60	63	28	3÷30	812-203003	ER40
214-35138	D40L80ER40	40	80	60	63	28	3÷30	812-203003	ER40
264-35191	D40L130ER40	40	130	60	63	28	3÷30	812-203003	ER40
264-35750	D44,45L160ER32	44,45	160	33	50	23	2÷20	812-203002	ER32
264-35751	D44,45L160ER40	44,45	160	40	63	28	3÷30	812-203003	ER40
264-35192	D50L125ER32	50	125	32	50	23	2÷20	812-203002	ER32
264-35193	D50L160ER32	50	160	32	50	23	2÷20	812-203002	ER32
264-35752	D50L125ER40	50	125	37	63	28	3÷30	812-203003	ER40
264-35194	D50L160ER40	50	160	37	63	28	3÷30	812-203003	ER40
264-35753	D50,8L160ER32	50,8	160	32	50	23	2÷20	812-203002	ER32
264-35754	D50,8L160ER40	50,8	160	37	63	28	3÷30	812-203003	ER40
264-35755	D60L160ER32	60	160	32	50	23	2÷20	812-203002	ER32
264-35756	D60L160ER40	60	160	37	63	28	3÷30	812-203003	ER40

D25÷D60 Zylinderschaft mit Fläche • Shank with flat • Queue cylindrique avec plat • Stelo con piano • Хвостовик с лыской • 柄不带平面

SPANNFUTTER MIT ZYLINDERSCHAFT MIT SECHSKANT MUTTER
CYLINDRICAL COLLET CHUCKS WITH HEXAGONAL NUT
ЦАНГОВЫЕ ПАТРОНЫ С ЦИЛИНДРИЧЕСКИМ
ХВОСТОВИКОМ С ШЕСТИГРАННОЙ ГАЙКОЙ

PORTE PINCES QUEUE CYLINDRIQUE AVEC ECROU EXAGONAL
PORTAPINZA GAMBO CILINDRICO CON GHIERA ESAGONALE
帶六角螺母的圓柱式彈簧夾頭

DIN 6499

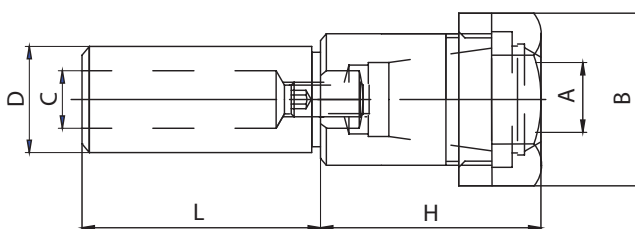

Code N.	Description	Dh6	L	H	B	C	Clamplng capacity	Nut	Description
214-35783	D14L60ER16E	14	60	36	28	7	1÷10	812-203009	ER16
214-35784	D16L60ER16E	16	60	36	28	7	1÷10	812-203009	ER16
214-35785	D16L80ER16E	16	80	36	28	7	1÷10	812-203009	ER16
214-35786	D16L100ER16E	16	100	36	28	7	1÷10	812-203009	ER16
214-35787	D16L130ER16E	16	130	36	28	7	1÷10	812-203009	ER16
214-35788	D16L160ER16E	16	160	36	28	7	1÷10	812-203009	ER16
214-35789	D16L200ER16E	16	200	36	28	7	1÷10	812-203009	ER16
214-35790	D16L60ER20E	16	60	40	34	9	1÷13	812-203010	ER20
214-35791	D19,05L50ER16E	19,05	50	32	28	11	1÷10	812-203009	ER16
214-35792	D19,05L100ER16E	19,05	100	32	28	11	1÷10	812-203009	ER16
214-35793	D19,05L50ER20E	19,05	50	36	34	11	1÷13	812-203010	ER20
214-35794	D19,05L100ER20E	19,05	100	36	34	11	1÷13	812-203010	ER20
214-35795	D20L50ER16E	20	50	31	28	11	1÷10	812-203009	ER16
214-35796	D20L100ER16E	20	100	31	28	11	1÷10	812-203009	ER16
214-35797	D20L130ER16E	20	130	31	28	11	1÷10	812-203009	ER16
214-35798	D20L160ER16E	20	160	31	28	11	1÷10	812-203009	ER16
214-35799	D20L200ER16E	20	200	31	28	11	1÷10	812-203009	ER16
264-35701	D20L46ER20E	20	46	36	34	11	1÷13	812-203010	ER20
264-35702	D20L60ER20E	20	60	36	34	11	1÷13	812-203010	ER20
264-35703	D20L100ER20E	20	100	36	34	11	1÷13	812-203010	ER20
264-35704	D20L130ER20E	20	130	36	34	11	1÷13	812-203010	ER20
264-35705	D20L160ER20E	20	160	36	34	11	1÷13	812-203010	ER20
264-35706	D20L200ER20E	20	200	36	34	11	1÷13	812-203010	ER20
264-35707	D22L80ER16E	22	80	26	28	11	1÷10	812-203009	ER16
264-35708	D22L80ER20E	22	80	36	34	11	1÷13	812-203010	ER20
264-35709	D25L60ER16E	25	60	27	28	11	1÷10	812-203009	ER16
264-35710	D25L100ER16E	25	100	27	28	11	1÷10	812-203009	ER16
264-35711	D25L130ER16E	25	130	27	28	11	1÷10	812-203009	ER16
264-35712	D25L160ER16E	25	160	27	28	11	1÷10	812-203009	ER16
264-35713	D25L200ER16E	25	200	27	28	11	1÷10	812-203009	ER16
264-35714	D25L60ER20E	25	60	28	34	13	1÷13	812-203010	ER20
264-35715	D25L100ER20E	25	100	28	34	13	1÷13	812-203010	ER20
264-35716	D25L130ER20E	25	130	28	34	13	1÷13	812-203010	ER20
264-35717	D25L160ER20E	25	160	28	34	13	1÷13	812-203010	ER20
264-35718	D25,4L60ER16E	25,4	60	27	28	11	1÷10	812-203009	ER16
264-35719	D25,4L100ER16E	25,4	100	27	28	11	1÷10	812-203009	ER16
264-35720	D25,4L60ER20E	25,4	60	28	34	13	1÷13	812-203010	ER20
264-35721	D25,4L100ER20E	25,4	100	28	34	13	1÷13	812-203010	ER20
264-35722	D32L100ER16E	32	100	27	28	11	1÷10	812-203009	ER16
264-35723	D32L150ER16E	32	150	27	28	11	1÷10	812-203009	ER16
264-35724	D32L100ER20E	32	100	28	34	13	1÷13	812-203010	ER20
264-35725	D32L150ER20E	32	150	28	34	13	1÷13	812-203010	ER20

D14÷D16 Zylinderschaft • Shank without flat • Queue cylindrique • Stelo senza piano • Хвостовик без лыски • 柄不带平面

D19,05÷D32 Zylinderschaft mit Fläche • Shank with flat • Queue cylindrique avec plat • Stelo con piano • Хвостовик с лыской • 柄带平面

SPANNFUTTER MIT ZYLINDERSCHAFT MIT MINI SPANNMUTTER
CYLINDRICAL DOUBLE COLLET CHUCKS WITH MINI NUT
ДВУСТОРОННИЕ ЦАНГОВЫЕ ПАТРОНЫ С МИНИ-ГАЙКОЙ

PORTE PINCES QUEUE CYLINDRIQUE AVEC ECROU MINI
PORTAPINZA DOPPI GAMBO CILINDRICO CON GHIERA MINI
带微型螺母的圆柱式双弹簧夹头

DIN 6499

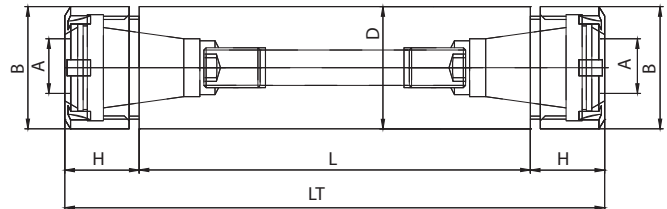

Code N.	Description	Dh6	L	H	LT	B	Clamping capacity	Nut	Description
264-35198	D20L42ER11MD	20	42	14	70	16	1÷7	812-203012	ER11M
264-35199	D20L52ER11MD	20	52	14	80	16	1÷7	812-203012	ER11M
214-35702	D20L62ER11MD	20	62	14	90	16	1÷7	812-203012	ER11M
214-35703	D20L37ER16MD	20	37	21,5	80	22	1÷10	812-203013	ER16M
214-35704	D20L57ER16MD	20	57	21,5	100	22	1÷10	812-203013	ER16M
214-35705	D20L67ER16MD	20	67	21,5	110	22	1÷10	812-203013	ER16M
214-35706	D20L122ER16MD	20	122	21,5	165	22	1÷10	812-203013	ER16M
214-35707	D22L47ER16MD	22	47	21,5	90	22	1÷10	812-203013	ER16M
214-35708	D22L67ER16MD	22	67	21,5	110	22	1÷10	812-203013	ER16M
214-35709	D22L102ER16MD	22	102	21,5	145	22	1÷10	812-203013	ER16M
214-35710	D25L27ER16MD	25	27	21,5	70	22	1÷10	812-203013	ER16M
214-35711	D25L47ER16MD	25	47	21,5	90	22	1÷10	812-203013	ER16M
214-35712	D25L67ER16MD	25	67	21,5	110	22	1÷10	812-203013	ER16M
214-35713	D25L82ER20MD	25	82	24	130	28	1÷13	812-203014	ER20M
264-35757	D32L57ER20MD	32	57	24	105	28	1÷13	812-203014	ER20M
264-35758	D32L82ER20MD	32	82	24	130	28	1÷13	812-203014	ER20M

SPANNZANGENAUFNAHME MIT MORSEKEGEL
COLLET CHUCKS WITH MORSE TAPER
ЦАНГОВЫЕ ПАТРОНЫ С КОНУСОМ МОРЗЕ

PORTE-OUTIL POUR SERRAGE PAR PINCE MK
PORTAPINZA CON ATTACCO CONO MORSE
莫氏锥度弹簧夹头

DIN 6499

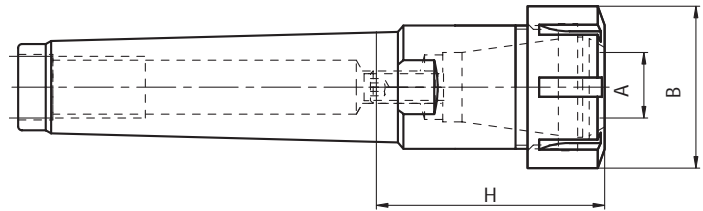

Code N.	Description	MK Morse	H	g	B	Clamplng capacity	Nut	Description
214-33102	CM1H40ER16	1	40	M6	32	0,5÷10	812-203005	ER16
214-33103	CM2H42ER16	2	42	M10	32	0,5÷10	812-203005	ER16
214-33104	CM2H50ER20	2	50	M10	35	0,5÷13	812-203006	ER20
214-33106	CM3H53ER25	3	53	M12	42	0,5÷16	812-203001	ER25
214-33107	CM3H70ER32	3	70	M12	50	2÷20	812-203002	ER32
214-33109	CM4H60ER32	4	60	M16	50	2÷20	812-203002	ER32
214-33110	CM4H81ER40	4	81	M16	63	3÷30	812-203003	ER40

SPANNZANGENAUFNAHME MIT MORSEKEGEL,
ANZUGSGEWINDE UND MINI MUTTER
COLLET CHUCKS WITH MORSE TAPER, WITH MINI NUT
ЦАНГОВЫЕ ПАТРОНЫ С КОНУСОМ МОРЗЕ С МИНИ-ГАЙКОЙ

PORTE-OUTIL POUR SERRAGE PAR PINCE MK, AVEC ECROU MINI
PORTAPINZA CON ATTACCO CONO MORSE, CON GHIERA MINI
带微型螺母的莫氏锥度弹簧夹头

DIN 6499

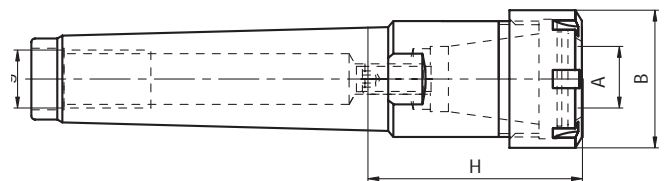

Code N.	Description	MK Morse	H	g	B	Clamplng capacity	Nut	Description
214-33119	CM1H25ER11M	1	25	M6	16	0,5÷7	812-203012	ER11M
214-33120	CM1H40ER16M	1	40	M6	22	0,5÷10	812-203013	ER16M
214-33121	CM2H42ER16M	2	42	M10	22	0,5÷10	812-203013	ER16M
214-33122	CM2H50ER20M	2	50	M10	28	0,5÷13	812-203014	ER20M
214-33123	CM2H54ER25M	2	54	M10	35	0,5÷16	812-203015	ER25M
214-33124	CM3H43ER16M	3	43	M12	22	0,5÷10	812-203013	ER16M
214-33125	CM3H47ER20M	3	47	M12	28	0,5÷13	812-203014	ER20M
214-33126	CM3H58ER25M	3	58	M12	35	0,5÷16	812-203015	ER25M

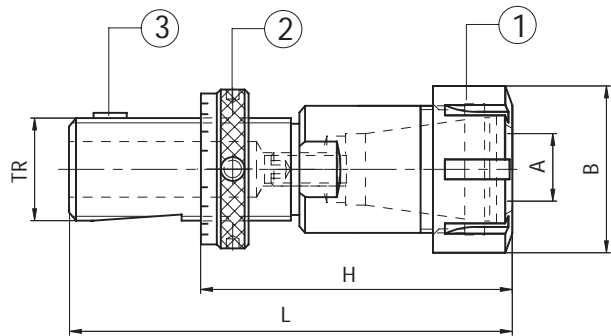

SPANNZANGENFUTTER DIN 6327 MANDRIN A PINCES DIN 6327
 COLLET CHUCK DIN 6327 PORTAPINZE ATTACCO DIN 6327
 ЦАНГОВЫЕ ПАТРОНЫ ПО DIN 6327 DIN 6327 弹簧夹头

DIN 6499

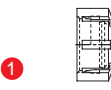
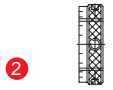

Code N.	Description	Tr	H min.	L	B	Clamping capacity	Type
214-34302	TR16X1.5L122ER16	16x1,5	46	122	28	0,5÷10	ER16
214-34303	TR20X2L128ER16	20x2	55	128	28	0,5÷10	ER16
214-34306	TR28X2L140ER20	28x2	61	140	34	0,5÷13	ER20
214-34307	TR28X2L140ER25	28x2	61	140	42	0,5÷16	ER25
214-34308	TR28X2L147ER32	28x2	68	147	50	2÷20	ER32
214-34310	TR36X2L165ER32	36x2	65	165	50	2÷20	ER32
214-34311	TR36X2L186ER40	36x2	86	186	63	3÷30	ER40

Ersatzteile • Spare parts • Pièces détachées • Componenti • Запасные части • 零件

Code N.	Nut	Nut	Tenon
			
214-34302	812-203005	812-204030	814-20279
214-34303	812-203005	812-204040	814-20279
214-34306	812-203006	812-204010	814-20281
214-34307	812-203001	812-204010	814-20281
214-34308	812-203002	812-204010	814-20282
214-34310	812-203002	812-204020	814-20283
214-34311	812-203003	812-204020	814-20283

KOMBI-AUFSTECKFRÄSDORNE MIT MORSEKEGEL MANDRINS PORTE-FRAISES A DOUBLE USAGE MK
 COMBI-SHELL MILL ADAPTORS WITH MORSE TAPER PORTAFRESE COMBINATI CON ATTACCO CONO MORSE
 КОМБИНИРОВАННЫЕ ОПРАВКИ ДЛЯ НАСАДНЫХ ФРЕЗ С КОНУСОМ МОРЗЕ 复合式平面铣刀弹簧夹头

DIN 6358

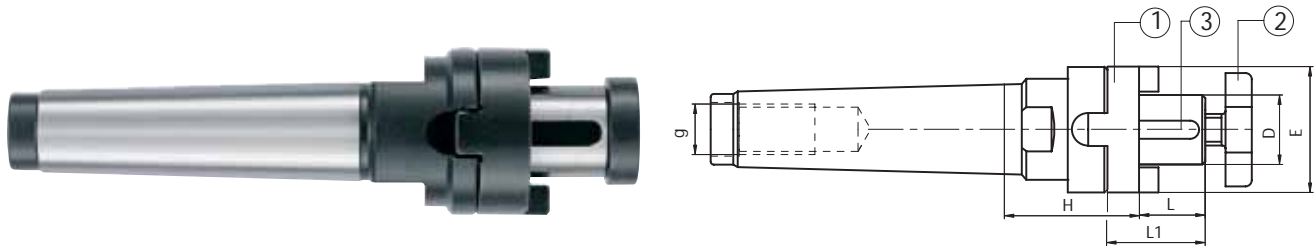

Code N.	Description	MK Morse	D	H	L1	L	E	g
216-13118	CM2H37D16C	2	16	37	27	17	32	M10
216-13119	CM2H42D22C	2	22	42	31	19	40	M10
216-13120	CM3H37D16C	3	16	37	27	17	32	M12
216-13121	CM3H42D22C	3	22	42	31	19	40	M12
216-13122	CM3H42D27C	3	27	42	33	21	48	M12
216-13123	CM3H63D32C	3	32	63	38	24	58	M12
216-13124	CM4H55D16C	4	16	55	27	17	32	M16
216-13125	CM4H55D22C	4	22	55	31	19	40	M16
216-13126	CM4H55D27C	4	27	55	33	21	48	M16
216-13127	CM4H55D32C	4	32	55	38	24	58	M16
216-13128	CM5H75D22C	5	22	75	31	19	40	M20
216-13129	CM5H75D27C	5	27	75	33	21	48	M20
216-13130	CM5H75D32C	5	32	75	38	24	58	M20
216-13131	CM5H75D40C	5	40	75	41	27	70	M20

Ersatzteile • Spare parts • Pièces détachées • Componenti • Запасные части • 零件

D	Ring	Screw	Key	Wrench
16	814-30001	811-107003	814-201010	816-130002
22	814-30002	811-107004	814-201020	816-130003
27	814-30003	811-107005	814-201030	816-130004
32	814-30004	811-107006	814-201040	816-130005
40	814-30005	811-107007	814-201050	816-130006

SPANNFUTTER MIT ZYLINDERSCHAFT MIT MINI SPANNMUTTER
WELDON COLLET CHUCKS WITH MINI NUT
ЦАНГОВЫЕ ПАТРОНЫ С ХВОСТОВИКОМ WELDON С МИНИ-ГАЙКОЙ

PORTE PINCES QUEUE WELDON AVEC ECROU MINI
PORTAPINZA GAMBO WELDON CON GHIERA MINI
带微型螺母的威尔登式弹簧夹头

DIN 6499

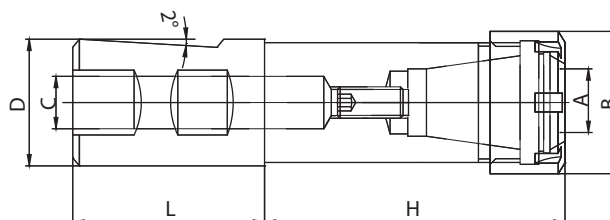

Code N.	Description	Dh6	L	H	B	C	Clamplng capacity	Nut	Description
214-35208	WE16H80ER11M	16	48	80	16	7	1÷7	812-203012	ER11M
214-35209	WE16H80ER16M	16	48	80	22	9	1÷10	812-203013	ER16M
214-35210	WE20H80ER16M	20	50	80	22	11	1÷10	812-203013	ER16M
214-35211	WE20H80ER20M	20	50	80	28	11	1÷13	812-203014	ER20M
214-35212	WE25H80ER16M	25	56	80	22	11	1÷10	812-203013	ER16M
214-35213	WE25H80ER20M	25	56	80	28	13	1÷13	812-203014	ER20M

SPANNFUTTER MIT ZYLINDERSCHAFT MIT STANDARD SPANNMUTTER
WELDON COLLET CHUCKS WITH STANDARD NUT
ЦАНГОВЫЕ ПАТРОНЫ С ХВОСТОВИКОМ WELDON СО СТАНДАРТНОЙ ГАЙКОЙ

PORTE PINCES QUEUE WELDON AVEC ECROU STANDARD
PORTAPINZA GAMBO WELDON CON GHIERA STANDARD
带标准螺母的威尔登式弹簧夹头

DIN 6499

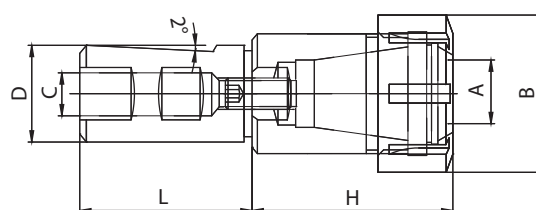

Code N.	Description	Dh6	L	H	B	C	Clamplng capacity	Nut	Description
214-35214	WE20H55ER32	20	50	55	50	11	2÷20	812-203002	ER32
214-35215	WE20H100ER32	20	50	100	50	11	2÷20	812-203002	ER32
214-35216	WE25H55ER32	25	56	55	50	13	2÷20	812-203002	ER32
214-35217	WE25H100ER32	25	56	100	50	13	2÷20	812-203002	ER32
214-35218	WE32H55ER32	32	60	55	50	23	2÷20	812-203002	ER32
214-35219	WE32H100ER32	32	60	100	50	23	2÷20	812-203002	ER32

WELDON REDUZIERHÜLSEN
WELDON REDUCTION SLEEVES
ПЕРЕХОДНИКИ WELDON НА УМЕНЬШЕНИЕ

DOUILLES DE REDUCTION WELDON
BUSSOLE DI RIDUZIONE WELDON
威尔登式铣刀套

DIN 1835 B

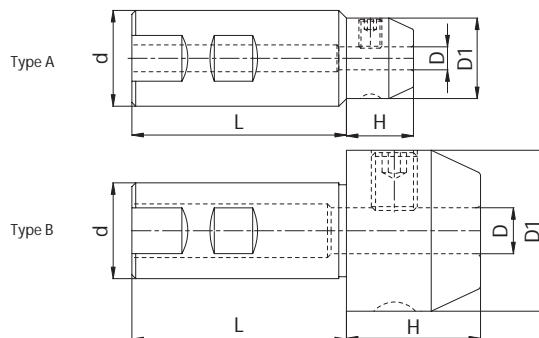

Code N.	Description	d	D	H	L	DI	Type
213-15203	WE20H30WE06	20	6	30	50	25	B
213-15204	WE20H30WE08	20	8	30	50	28	B
213-15205	WE20H30WE10	20	10	30	50	35	B
213-15206	WE20H35WE12	20	12	35	50	42	B
213-15207	WE20H35WE14	20	14	35	50	44	B
213-15208	WE20H60WE16	20	16	60	50	48	B
213-15209	WE25H25WE06	25	6	25	56	25	A
213-15210	WE25H30WE08	25	8	30	56	28	B
213-15211	WE25H30WE10	25	10	30	56	35	B
213-15212	WE25H35WE12	25	12	35	56	42	B
213-15213	WE25H35WE14	25	14	35	56	44	B
213-15214	WE25H40WE16	25	16	40	56	48	B
213-15215	WE32H30WE06	32	6	30	60	25	A
213-15216	WE32H30WE08	32	8	30	60	28	A
213-15217	WE32H30WE10	32	10	30	60	35	B
213-15218	WE32H35WE12	32	12	35	60	42	B
213-15219	WE32H35WE14	32	14	35	60	44	B
213-15220	WE32H40WE16	32	16	40	60	48	B
213-15221	WE32H40WE18	32	18	40	60	50	B
213-15222	WE32H40WE20	32	20	40	60	52	B
213-15223	WE32H65WE25	32	25	65	60	65	B

SPANNZANGENFUTTER BRIDGEPORT R8 MANDRINS A PINCES BRIDGEPORT R8
 COLLET CHUCK BRIDGEPORT R8 PORTAPINZE ATTACCO BRIDGEPORT R8
 ЦАНГОВЫЕ ПАТРОНЫ БРИДЖПОРТ R8 R8 弹簧夹头桥路端口

DIN 6499

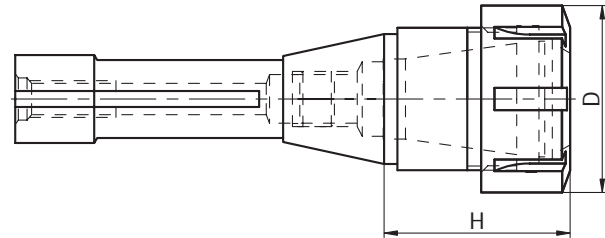

Code N.	Description	H	D	Clamping capacity	Type	Nut
214-36401	R8H40ER32	40	50	2÷20	ER32	812-203002
214-36402	R8H73ER40	73	63	3÷30	ER40	812-203003

AUFSTECKFRÄSDORNE FÜR FRÄSER MIT QUERNUT BRIDGEPORT R8 PORTE-FRAISE-ENTRAINEMENT PAR TENONS BRIDGEPORT R8
 MILL HOLDERS-TENONS DRIVE BRIDGEPORT R8 PORTAFRESE A TRASCINAMENTO FISSO BRIDGEPORT R8
 ОПРАВКИ БРИДЖПОРТ R8 ДЛЯ НАСАДНЫХ ФРЕЗ R8 铣刀夹具 - 凸榫驱动桥路端口

ISO 3937

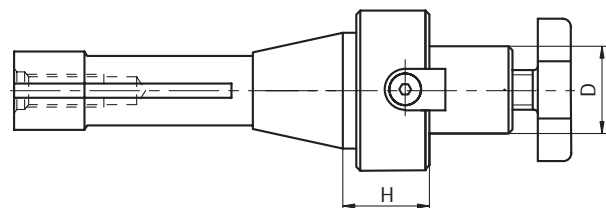

Ersatzteile • Spare parts • Pièces détachées • Componenti • Запасные части • 零件

Code N.	Description	D	H
216-76401	R8H19D16F	16	19
216-76402	R8H23D22F	22	23
216-76403	R8H23D27F	27	23
216-76404	R8H24D32F	32	24

PRÄZISIONSBOHRFUTTER - RECHTSLAUF
 MONOLITHIC DRILL CHUCKS - RIGHT SPIN
 СВЕРЛИЛЬНЫЕ ПАТРОНЫ. ВРАЩЕНИЕ ПО ЧАСОВОЙ СТРЕЛКЕ.

MANDRINS DE PERCAGE - ROTATION DROITE
 MANDRINI AUTOSERRANTI INTEGRALI - ROTAZIONE DESTRA
 合成钻夹头-右旋转

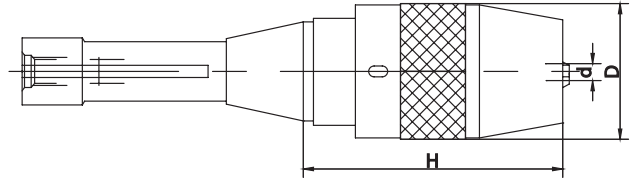

Code N.	Description	H	D	Clamping capacity	Type
252-16401	R8H81R1-13	81	50	1-13	816-152001

RUNDLAUFGENAUIGKEIT 0.05 MM
 RUNOUT ACCURACY 0.05 MM
 БИЕНИЕ 0.05 MM
 PRECISION DE ROTATION 0.05 MM
 PRECISIONE DI ROTAZIONE 0.05 MM
 跳动精度0.05MM

GEWINDESCHNEID-SCHNELLWECHSELFUTTER
 MIT LANGENAUSGLEICH MIT ZYLINDERSCHAFT
 CYLINDRICAL TAP CHUCKS
 CON CODOLO CILINDRICO

MANDRIN DE TARAUDAGE AVEC QUEUE CYLINDRIQUE
 MASCHIATORE A DOPPIA COMPENSAZIONE
 筒式丝锥夹头

DIN 1835 B+E

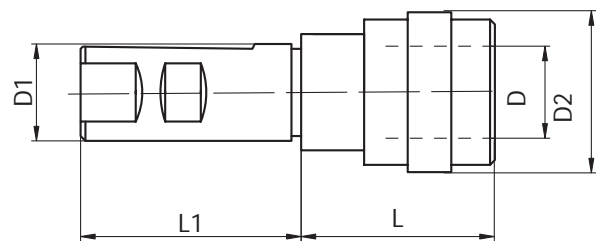

Code N.	Description	D1	Size	Top range	D	D2	L	L1	Comp	Ext
M401020	M3-M12CIL.D20GR1	20	1	M3÷M12	19	38	41	50	9	9
M401025	M3-M12CIL.D25GR1	25	1	M3÷M12	19	38	41	56	9	9
M401032	M3-M12CIL.D32GR1	32	1	M3÷M12	19	38	41	61	9	9
M401040	M3-M12CIL.D40GR1	40	1	M3÷M12	19	38	41	72	9	9
M402020	M6-M20CIL.D20GR2	20	2	M6÷M20	31	55	63	50	15	15
M402025	M6-M20CIL.D25GR2	25	2	M6÷M20	31	55	63	56	15	15
M402032	M6-M20CIL.D32GR2	32	2	M6÷M20	31	55	63	61	15	15
M402040	M6-M20CIL.D40GR2	40	2	M6÷M20	31	55	63	72	15	15
M403032	M14-M33CIL.D32GR3	32	3	M14÷M33	48	79	109	61	24	24
M403040	M14-M33CIL.D40GR3	40	3	M14÷M33	48	79	98	72	24	24

PENDELHALTER
 FLOATING TOOLHOLDERS FOR RD/ER COLLETS
 ПЛАВАЮЩИЕ ПАТРОНЫ ДЛЯ RD/ER ЦАНГ

PORTE-OUTILS FLOTTANTS A PINCES RD/ER
 PORTA ALESATORI OSCILLANTE
 RD/ER 弹簧夹头筒夹浮动刀柄

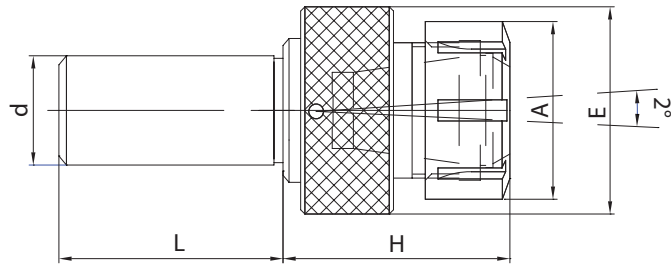

Code N.	d	L	H	d1	ER
832-021184	16	46	40	2-7	ER11
832-021185	25	46	48	2-13	ER20
832-021186	25	46	50	2-16	ER25
832-021187	25	50	58	3-20	ER32

MK AUFNAHMESCHAFT
 TENONS
 ШПИЛЬКИ

TONQUES
 TENONI
 凸榫

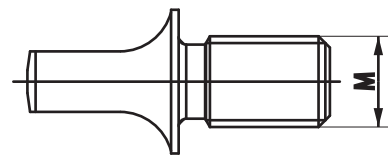

Type	M
TENONE CM1	M6
TENONE CM2	M10
TENONE CM3	M12
TENONE CM4	M16
TENONE CM5	M20

SCHNELLSPANNBOHRFUTTER MANDRINS PORTE-FORET A SERRAGE RAPIDE
 KEYLESS DRILL CHUCKS MANDRINI AUTOSERRANTI
 САМОЗАЖИМНЫЕ СВЕРЛИЛЬНЫЕ ПАТРОНЫ 自紧式钻夹头

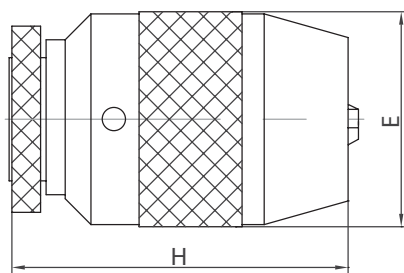

Code N.	Type	Clamping capacity	H	E	Wrench	Jaws
252-16601	B10-DC6	0,5 - 6,5	60	35	--	832-012014
252-16602	B10-DC8	0 - 8	69	38	--	832-012015
252-16603	B10-DC10	0 - 10	79	43	816-152005	832-012016
252-16604	B12-DC8	0 - 8	69	38	---	832-012015
252-16605	B12-DC10	0 - 10	79	43	816-152005	832-012016
252-16606	B12-DC13	0 - 13	90	51	816-152001	832-012017
252-16607	B16-DC10	0 - 10	79	43	816-152005	832-012018
252-16608	B16-DC13	0 - 13	90	51	816-152001	832-012017
252-16609	B16-DC16	3 - 16	94	57	816-152001	832-012019
252-16610	B18-DC16	3 - 16	94	57	816-152001	832-012019

RUNDLAUFGENAUIGKEIT 0.07 MM • RUNOUT ACCURACY 0.07 MM • БИЕНИЕ 0.07 MM
 PRECISION DE ROTATION 0.07 MM • PRECISIONE DI ROTAZIONE 0.07 MM • 跳动精度0.07MM

PRAZISIONS SCHNELLSPANNBOHRFUTTER MANDRINS PORTE-FORET A SERRAGE RAPIDE
 KEYLESS PRECISION DRILL CHUCKS MANDRINI AUTOSERRANTI DI ALTA PRECISIONE
 САМОЗАЖИМНЫЕ ПРЕЦИЗИОННЫЕ СВЕРЛИЛЬНЫЕ ПАТРОНЫ 自紧式精密钻夹头

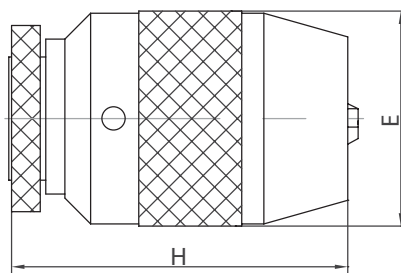

Code N.	Type	Clamping capacity	H	E	Wrench	Jaws
252-16611	B10-DC8 Precision	0 – 8	69	38	--	832-012015
252-16612	B10-DC10 Precision	0 – 10	79	43	816-152005	832-012016
252-16613	B12-DC8 Precision	0 – 8	69	38	---	832-012015
252-16614	B12-DC10 Precision	0 – 10	79	43	816-152005	832-012016
252-16615	B12-DC13 Precision	0 – 13	90	51	816-152001	832-012020
252-16616	B16-DC10 Precision	0 – 10	79	43	816-152005	832-012018
252-16617	B16-DC13 Precision	0 – 13	90	51	816-152001	832-012020
252-16618	B16-DC16 Precision	3 – 16	95	57	816-152001	832-012021
252-16619	B18-DC16 Precision	3 – 16	95	57	816-152001	832-012021

RUNDLAUFGENAUIGKEIT ≤ 0.05 MM • RUNOUT ACCURACY ≤ 0.05 MM • БИЕНИЕ ≤ 0.05 MM
 PRECISION DE ROTATION ≤ 0.05 MM • PRECISIONE DI ROTAZIONE ≤ 0.05 MM • 跳动精度不大于0.05MM

PRÄZISIONSBOHRFUTTER - RECHTSLAUF
MONOLITHIC DRILL CHUCKS - RIGHT SPIN
ПРЕЦИЗИОННЫЕ СВЕРЛИЛЬНЫЕ ПАТРОНЫ - ВРАЩЕНИЕ ВПРАВО

MANDRINS DE PERCAGE - ROTATION DROITE
MANDRINI AUTOSERRANTI INTEGRALI - ROTAZIONE DESTRA
整体式钻夹头-右旋

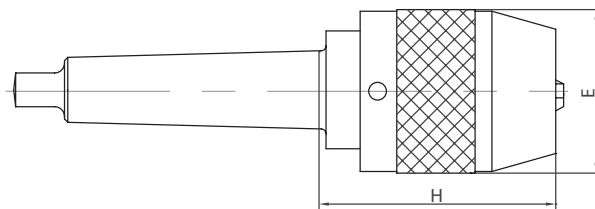

Code N.	Type	Clamping capacity	H	E	Wrench
252-13301	CM2-DC13	1 - 13	86	50	816-152001
252-13302	CM3-DC13	1 - 13	86	50	816-152001
252-13303	CM3-DC16	3 - 16	90	57	816-152001
252-13304	CM4-DC13	1 - 13	87	50	816-152001
252-13305	CM4-DC16	3 - 16	91	57	816-152001

RUNDLAUFGENAUIGKEIT 0.05 MM • RUNOUT ACCURACY 0.05 MM • БИЕНИЕ 0.05 MM
PRECISION DE ROTATION 0.05 MM • PRECISIONE DI ROTAZIONE 0.05 MM • 跳动精度不大于0.05MM

PRÄZISIONSBOHRFUTTER - RECHTS- UND LINKSLAUF
MONOLITHIC DRILL CHUCKS - RIGHT & LEFT SPIN
ПРЕЦИЗИОННЫЕ СВЕРЛИЛЬНЫЕ ПАТРОНЫ
ВРАЩЕНИЕ ВПРАВО И ВЛЕВО

MANDRINS DE PERCAGE - ROTATION GAUCHE-DROITE
MANDRINI AUTOSERRANTI INTEGRALI
ROTAZIONE DESTRA E SINISTRA
整体式钻夹头-左右旋转

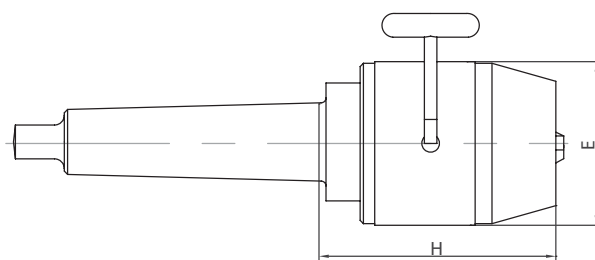

Code N.	Type	Clamping capacity	H	E	Wrench
252-13307	CM3-DCU13	1 - 13	87	50	816-111028
252-13308	CM3-DCU16	3 - 16	92	50	816-111028
252-13309	CM4-DCU13	1 - 13	88	50	816-111028
252-13310	CM4-DCU16	3 - 16	94	50	816-111028

RUNDLAUFGENAUIGKEIT 0.05 MM • RUNOUT ACCURACY 0.05 MM • БИЕНИЕ 0.05 MM
PRECISION DE ROTATION 0.05 MM • PRECISIONE DI ROTAZIONE 0.05 MM • 跳动精度0.05MM

SCHNELLSPANNBOHRFUTTER
MIT ZYLINDERSCHAFT - RECHTSLAUF
STRAIGHT SHANK MONOLITHIC DRILL CHUCKS - RIGHT SPIN
СВЕРЛИЛЬНЫЕ ПАТРОНЫ С ЦИЛИНДРИЧЕСКИМ ХВОСТОВИКОМ
ВРАЩЕНИЕ ВПРАВО

MANDRINS DE PERCAGE
AVEC QUEUE CYLINDRIQUE - ROTATION DROITE
MANDRINI AUTOSERRANTI INTEGRALI
CON ATTACCO CILINDRICO - ROTAZIONE DESTRA
整体式钻夹头-右旋

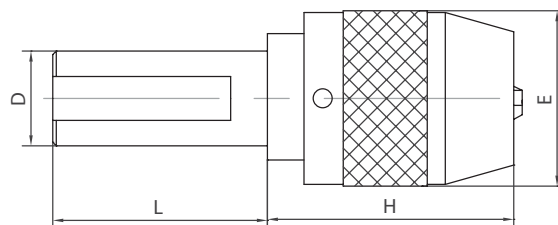

Code N.	Type	Clamping capacity	H	E	L	Wrench
252-15701	D20-DC13	1 - 13	81	50	60	816-152001
252-15702	D25-DC13	1 - 13	81	50	80	816-152001
252-15703	D32-DC13	1 - 13	81	50	60	816-152001
252-15704	D32-DC16	3 - 16	85	57	60	816-152001
252-15705	D40-DC13	1 - 13	81	50	70	816-152001
252-15706	D40-DC16	3 - 16	85	57	70	816-152001

RUNDLAUFGENAUIGKEIT 0.05 MM • RUNOUT ACCURACY 0.05 MM • БИЕНИЕ 0.05 MM
PRECISION DE ROTATION 0.05 MM • PRECISIONE DI ROTAZIONE 0.05 MM • 跳动精度不大于0.05MM

SCHNELLSPANNBOHRFUTTER
MIT ZYLINDERSCHAFT UND IK - RECHTS- UND LINKSLAUF
STRAIGHT SHANK INSIDE
COOLING MONOLITHIC DRILL CHUCKS - RIGHT & LEFT
СВЕРЛИЛЬНЫЕ ПАТРОНЫ С ВНУТРЕННИМ ПОДВОДОМ СОЖ С
ЦИЛИНДРИЧЕСКИМ ХВОСТОВИКОМ - ВРАЩЕНИЕ ВПРАВО, ВЛЕВО

MANDRINS DE PERCAGE AVEC QUEUE CYLINDRIQUE
ET ARROSAGE CENTRALE - ROTATION DROITE ET GAUCHE
MANDRINI AUTOSERRANTI INTEGRALI
CON ATTACCO CILINDRICO - ROTAZIONE DESTRA E SINISTRA
CON PASSAGGIO REFRIGERANTE
整体式钻夹头-左右旋转

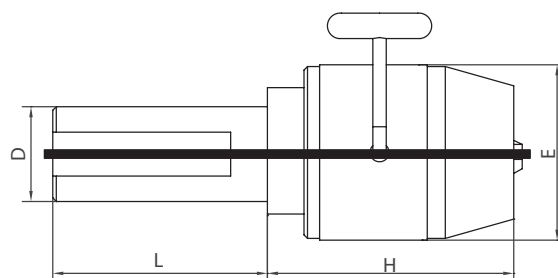

Code N.	Type	Clamping capacity	H	E	L	Wrench
252-15709	D32-DCU13C	1 - 13	82	50	60	816-111028
252-15710	D32-DCU16C	3 - 16	87	57	60	816-111028
252-15711	D40-DCU13C	1 - 13	82	50	70	816-111028
252-15712	D40-DCU16C	3 - 16	87	57	70	816-111028

RUNDLAUFGENAUIGKEIT 0.05 MM • RUNOUT ACCURACY 0.05 MM • БИЕНИЕ 0.05 MM
PRECISION DE ROTATION 0.05 MM • PRECISIONE DI ROTAZIONE 0.05 MM • 跳动精度0.05MM

FRASDORNRINGE FÜR KOMBI AUFSTECKFRASDORNE
SPACING COLLARS FOR COMBI-SHELL MILL HOLDERS
КОЛЬЦА К КОМБИНИРОВАННЫМ ОПРАВКАМ ДЛЯ НАСАДНЫХ ФРЕЗ

BAGUES D'ESPACEMENT POUR PORTE FRAISES COMBINES
ANELLI DISTANZIATORI PER MANDRINI PORTAFRESE COMBINATI
复合式平面铣刀杆间隔铆合扣件

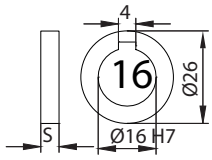

Code N.	S mm	Code N.	S mm	Code N.	S mm	Code N.	S mm
K4084SP003	0,03	K4084SP010	0,1	K4084BSP01	1	K4084BSP10	10
K4084SP004	0,04	K4084SP020	0,2	K4084BSP02	2	K4084BSP20	20
K4084SP005	0,05	K4084SP030	0,3	K4084BSP03	3	K4084BSP30	30
K4084SP006	0,06	K4084SP040	0,4	K4084BSP04	4		
		K4084SP050	0,5	K4084BSP05	5		
		K4084SP060	0,6	K4084BSP06	6		

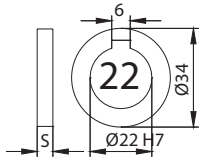

Code N.	S mm	Code N.	S mm	Code N.	S mm	Code N.	S mm
K4085SP003	0,03	K4085SP010	0,1	K4085BSP01	1	K4085BSP10	10
K4085SP004	0,04	K4085SP020	0,2	K4085BSP02	2	K4085BSP20	20
K4085SP005	0,05	K4085SP030	0,3	K4085BSP03	3	K4085BSP30	30
K4085SP006	0,06	K4085SP040	0,4	K4085BSP04	4	K4085BSP60	60
		K4085SP050	0,5	K4085BSP05	5		
		K4085SP060	0,6	K4085BSP06	6		

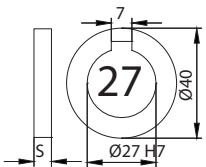

Code N.	S mm	Code N.	S mm	Code N.	S mm	Code N.	S mm
K4086SP003	0,03	K4086SP010	0,1	K4086BSP01	1	K4086BSP10	10
K4086SP004	0,04	K4086SP020	0,2	K4086BSP02	2	K4086BSP20	20
K4086SP005	0,05	K4086SP030	0,3	K4086BSP03	3	K4086BSP30	30
K4086SP006	0,06	K4086SP040	0,4	K4086BSP04	4	K4086BSP60	60
		K4086SP050	0,5	K4086BSP05	5		
		K4086SP060	0,6	K4086BSP06	6		

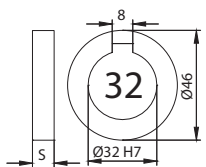

Code N.	S mm	Code N.	S mm	Code N.	S mm	Code N.	S mm
K4087SP003	0,03	K4087SP010	0,1	K4087BSP01	1	K4087BSP10	10
K4087SP004	0,04	K4087SP020	0,2	K4087BSP02	2	K4087BSP20	20
K4087SP005	0,05	K4087SP030	0,3	K4087BSP03	3	K4087BSP30	30
K4087SP006	0,06	K4087SP040	0,4	K4087BSP04	4	K4087BSP60	60
		K4087SP050	0,5	K4087BSP05	5		
		K4087SP060	0,6	K4087BSP06	6		

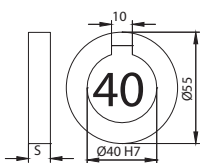

Code N.	S mm	Code N.	S mm	Code N.	S mm	Code N.	S mm
K4088SP003	0,03	K4088SP010	0,1	K4088BSP01	1	K4088BSP10	10
K4088SP004	0,04	K4088SP020	0,2	K4088BSP02	2	K4088BSP20	20
K4088SP005	0,05	K4088SP030	0,3	K4088BSP03	3	K4088BSP30	30
K4088SP006	0,06	K4088SP040	0,4	K4088BSP04	4	K4088BSP60	60
		K4088SP050	0,5	K4088BSP05	5		
		K4088SP060	0,6	K4088BSP06	6		

GEWINDESCHNEID-SCHNELLWECHSELFUTTER
MIT LÄNGENAUSGLEICH UND MORSEKEGELSCHAFT
QUICK CHANGE TAP HOLDER WITH MORSE TAPER SHANK
БЫСТРОСМЕННЫЕ РЕЗЬБОНАРЕЗНЫЕ ПАТРОНЫ
С КОНУСОМ МОРСЕ С ЛАПКОЙ

MANDRIN DE TARAUDAGE CONE MORSE
A CHANGEMENT RAPIDE
MASCHIATORE A DOPPIA COMPENSAZIONE
ATTACCO CONO MORSE
快换丝锥夹头带莫氏锥柄

DIN 228-B

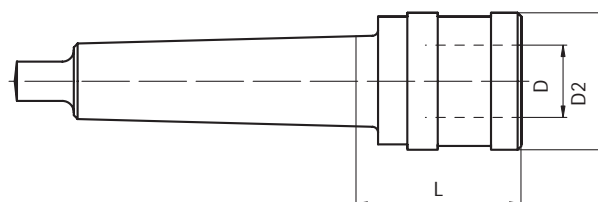

Code N.	Description	Size	Top range	Press	Ext	Mk Morse	D	D2	L
M-1810	M3-M12CM2BGR1	1	M3÷M12	9	9	2	19	38	46
M-1820	M3-M12CM3BGR1	1	M3÷M12	9	9	3	19	38	46
M-1920	M6-M20CM3BGR2	2	M6÷M20	15	15	3	31	55	69
M-1930	M6-M20CM4BGR2	2	M6÷M20	15	15	4	31	55	70
M-2030	M14-M33CM4BGR3	3	M14÷M33	24	24	4	48	79	108
M-2040	M14-M33CM5BGR3	3	M14÷M33	24	24	5	48	79	103

GEWINDESCHNEID-SCHNELLWECHSELFUTTER
MIT LÄNGENAUSGLEICH UND MORSEKEGELSCHAFT
QUICK CHANGE TAP HOLDER WITH MT SHANK
БЫСТРОСМЕННЫЕ РЕЗЬБОНАРЕЗНЫЕ ПАТРОНЫ
С КОНУСОМ МОРСЕ С РЕЗЬБОЙ

MANDRIN DE TARAUDAGE CONE MORSE
A CHANGEMENT RAPIDE
MASCHIATORE A DOPPIA COMPENSAZIONE
ATTACCO CONO MORSE
快换丝锥夹头带MT柄

DIN 228-A

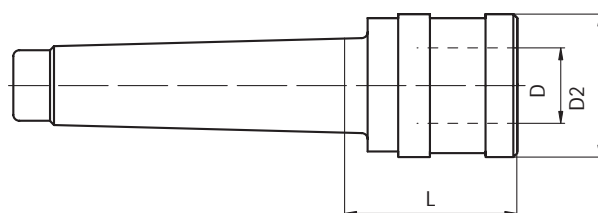

Code N.	Description	Size	Top range	Press	Ext	Mk Morse	D	D2	L
M-2210	M3-M12CM2AGR1	1	M3÷M12	9	9	2	19	36	46
M-2220	M3-M12CM3AGR1	1	M3÷M12	9	9	3	19	36	46
M-2320	M6-M20CM3AGR2	2	M6÷M20	15	15	3	31	53	68
M-2330	M6-M20CM4AGR2	2	M6÷M20	15	15	4	31	53	70

SCHNELLWECHSELEINSÄTZE OHNE SICHERHEITSKUPPLUNG
 QUICK CHANGE TAPPING ADAPTERS WITHOUT SAFETY COUPLING
 БЫСТРОСМЕННЫЕ РЕЗЬБОНАРЕЗНЫЕ АДАПТЕРЫ
 БЕЗ ПРЕДОХРАНЯЮЩЕЙ МУФТЫ

ADAPTEURS A CHANGEMENT RAPIDE SANS
 COUPLAGE DE SECURITE
 BUSSOLA PER MASCHIARE SENZA FRIZIONE
 快换丝锥接头不带安全连接器

IBC

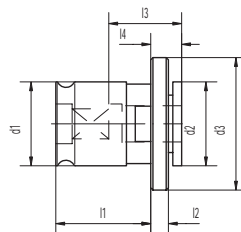

	Code N.	Top shank	∅	Size	l1	l2	l3	l4	d1	d2	d3
IBC 1	IBC1-2,80	2,8	2,1	1	21,5	4	17	7	19	19	30
	IBC1-3,15	3,15	2,5	1	21,5	4	17	7	19	19	30
	IBC1-3,50	3,5	2,7	1	21,5	4	17	7	19	19	30
	IBC1-4,0	4	3	1	21,5	4	17	7	19	19	30
	IBC1-4,0	4	3,15	1	21,5	4	17	7	19	19	30
	IBC1-4,0	5	3,15	1	21,5	4	17	7	19	19	30
	IBC1-4,5	4,5	3,4	1	21,5	4	17	7	19	19	30
	IBC1-5,0	5	4	1	21,5	4	17	7	19	19	30
	IBC1-5,5	5,5	4,3	1	21,5	4	17	7	19	19	30
	IBC1-6,0	6	4,9	1	21,5	4	17	7	19	19	30
	IBC1-6,3	6,3	5	1	21,5	4	17	7	19	19	30
	IBC1-7,0	7	5,5	1	21,5	4	17	7	19	19	30
	IBC1-8,0	8	6,2	1	21,5	4	17	7	19	19	30
	IBC1-8,0	8	6,3	1	21,5	4	17	7	19	19	30
IBC1-9,0	9	7	1	21,5	4	17	7	19	19	30	
IBC1-10	10	8	1	21,5	4	17	7	19	19	30	
IBC1-11	11	9	1	21,5	4	17	7	19	19	30	
IBC1-12	12	9	1	21,5	4	17	7	19	19	30	
IBC 2	IBC2-6,0	6	4,9	2	35	5	30	11	31	30	48
	IBC2-6,5	6,3	5	2	35	5	30	11	31	30	48
	IBC2-7,0	7	5,5	2	35	5	30	11	31	30	48
	IBC2-8,0	8	6,2	2	35	5	30	11	31	30	48
	IBC2-9,0	9	7	2	35	5	30	11	31	30	48
	IBC2-10	10	8	2	35	5	30	11	31	30	48
	IBC2-11	11	9	2	35	5	30	11	31	30	48
	IBC2-12	12	9	2	35	5	30	11	31	30	48
	IBC2-12,5	12,5	10	2	35	5	30	11	31	30	48
	IBC2-14	14	11	2	35	5	30	11	31	30	48
	IBC2-16	16	12	2	35	5	30	11	31	30	48
	IBC2-16	16	12,5	2	35	5	30	11	31	30	48
IBC2-18	18	14,5	2	35	5	30	11	31	30	48	
IBC2-20	20	16	2	35	5	30	11	31	30	48	
IBC 3	IBC3-11	11	9	3	55,5	6	44	14	48	48	70
	IBC3-12	12	9	3	55,5	6	44	14	48	48	70
	IBC3-14	14	11	3	55,5	6	44	14	48	48	70
	IBC3-16	16	12	3	55,5	6	44	14	48	48	70
	IBC3-18	18	14,5	3	55,5	6	44	14	31	30	70
	IBC3-20	20	16	3	55,5	6	44	14	48	48	70
	IBC3-22	22	18	3	55,5	6	44	14	48	48	70
	IBC3-25	25	20	3	55,5	6	44	14	48	48	70
	IBC3-28	28	22	3	55,5	6	44	14	48	48	70
IBC3-32	32	24	3	55,5	6	44	14	48	48	70	
IBC3-36	36	29	3	5,55	6	44	14	48	48	70	

SCHNELLWECHSELEINSÄTZE MIT SICHERHEITSKUPPLUNG
 QUICK CHANGE TAPPING ADAPTERS WITH SAFETY COUPLING
 БЫСТРОСМЕННЫЕ РЕЗЬБОНАРЕЗНЫЕ АДАПТЕРЫ
 С ПРЕДОХРАНЯЮЩЕЙ МУФТОЙ

ADAPTEURS A CHANGEMENT RAPIDE
 AVEC COUPLAGE DE SECURITE
 BUSSOLA PER MASCHIARE CON FRIZIONE
 快换丝锥接头带安全连接器

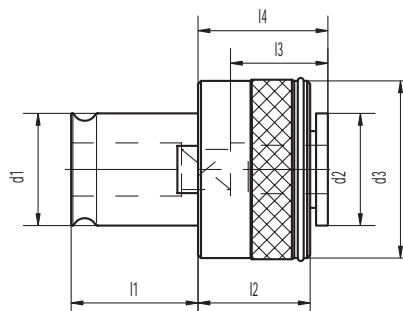

IBS

	Code N.	Top shank	∇	Size	l1	l2	l3	l4	d1	d2	d3
IBS 1	IBS1-3,5	3,5	2,7	1	21,5	25	17	25	19	19	32
	IBS1-4,5	4,5	3,4	1	21,5	25	17	25	19	19	32
	IBS1-5,5	5,5	4,3	1	21,5	25	17	25	19	19	32
	IBS1-6	6	4,9	1	21,5	25	17	25	19	19	32
	IBS1-7	7	5,5	1	21,5	25	17	25	19	19	32
	IBS1-8	8	6,2	1	21,5	25	17	25	19	19	32
	IBS1-9	9	7	1	21,5	25	17	25	19	19	32
	IBS1-10	10	8	1	21,5	25	17	25	19	19	32
	IBS1-11	11	9	1	21,5	25	17	25	19	19	32
	IBS 2	IBS2-6	6	4,9	2	35	31	30	34	31	30
IBS2-7		7	5,5	2	35	31	30	34	31	30	50
IBS2-8		8	6,2	2	35	31	30	34	31	30	50
IBS2-9		9	7	2	35	31	30	34	31	30	50
IBS2-10		10	8	2	35	31	30	34	31	30	50
IBS2-11		11	9	2	35	31	30	34	31	30	50
IBS2-12		12	9	2	35	31	30	34	31	30	50
IBS2-14		14	11	2	35	31	30	34	31	30	50
IBS2-16		16	12	2	35	31	30	34	31	30	50
IBS2-18		18	14,5	2	35	31	30	34	31	30	50
IBS 3	IBS3-11	11	9	3	55,5	41	44	45	48	48	72
	IBS3-12	12	9	3	55,5	41	44	45	48	48	72
	IBS3-14	14	11	3	55,5	41	44	45	48	48	72
	IBS3-16	16	12	3	55,5	41	44	45	48	48	72
	IBS3-18	18	14,5	3	55,5	41	44	45	48	48	72
	IBS3-20	20	16	3	55,5	41	44	45	48	48	72
	IBS3-22	22	18	3	55,5	41	44	45	48	48	72
	IBS3-25	25	20	3	55,5	41	44	45	48	48	72
	IBS3-28	28	22	3	55,5	41	44	45	48	48	72

REDUZIERUNGEN FÜR EINSÄTZE
 REDUCTIONS FROM ADAPTER TO ADAPTER
 ПЕРЕХОДНИКИ К АДАПТЕРАМ

REDUCTIONS POUR ADAPTEURS
 RIDUZIONI DA BUSSOLA A BUSSOLA
 接头与接头之间的缩小

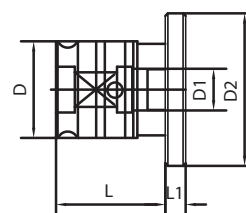

Code N.	D	D1	D2	L	L1
IBC1/0	19	13	30	21,5	4
IBC2/1	31	19	48	35	5
IBC3/2	48	31	70	55,5	6

TECHNISCHE DATEN DONNÉES TECHNIQUES
 TECHNICAL INFORMATION INFORMAZIONI TECNICHE
 ТЕХНИЧЕСКАЯ ИНФОРМАЦИЯ 技術信息

Tap Shank Dimension ISO 529 - 1975

Dimension Dia. x Square	Metric		UNC		UNF		BSW		BSF		BA	
		Shank dia. enlarged		Shank dia. enlarged		Shank dia. enlarged		Shank dia. enlarged		Shank dia. enlarged		Shank dia. enlarged
3.15 x 2.5	M4	M3	-	No. 4-40	-	No. 4-48	-	-	-	-	-	No. 5
3.55 x 2.8	M4.5	M3.5	No. 8-32	No. 5-40	No. 8-36	No. 5-44	-	-	-	-	No. 3	-
4 x 3.15	M5	M4	No. 10-24	No. 6-32	No. 10-32	No. 6-40	3/16"-24	-	3/16"-32	-	No. 2	No. 4
4.5 x 3.55	M6	-	No. 12-24	-	No. 12-28	-	-	-	7/32"-28	-	No. 1	-
5 x 4	M6	-	1/4"-20	No. 8-32	1/4"-28	No. 3-36	1/4"-20	-	1/4"-26	-	No. 0	No. 3
5.6 x 4.5	-	M5	-	No. 10-24	-	No. 10-32	-	3/16"-24	-	3/16"-32	-	No. 2
6.3 x 5	M8	M6	5/16"-18	1/4"-20	5/16"-24	1/4"-28	5/16"-18	1/4"-20	5/16"-22	1/4"-26	-	No. 1
7.1 x 5.6	-	-	3/8"-16	-	3/8"-24	-	3/8"-16	-	3/8"-20	9/32"-36	-	No. 0
8 x 6.3	M10	M8	7/16"-14	5/16"-18	7/16"-20	-	7/16"-14	5/16"-18	7/16"-18	5/16"-22	-	-
9 x 7.1	M12	-	1/2"-13	-	1/2"-20	-	1/2"-12	-	1/2"-12	-	-	-
10 x 8	-	M10	-	3/8"-16	-	3/8"-24	-	3/8"-16	-	3/8"-20	-	-
11.2 x 9	M14	-	9/16"-12	-	9/16"-18	-	9/16"-12	-	9/16"-16	-	-	-
12.5 x 10	M16	-	5/8"-11	-	5/8"-18	-	5/8"-11	-	3/8"-14	-	-	-
14 x 11.2	M18	-	3/4"-10	-	3/4"-16	-	11/16"-11	-	11/16"-14	-	-	-
16 x 12.5	M20	-	-	-	-	-	3/4"-10	-	3/4"-12	-	-	-
18 x 14	M22	-	7/8"-9	-	7/8"-14	-	7/8"-9	-	7/8"-11	-	-	-
20 x 16	M24	-	1"-8	-	1"-12	-	1"-8	-	1"-10	-	-	-
22.4 x 18	M27	-	1 1/8"-7	-	1 1/8"-12	-	1 1/8"-7	-	1 1/8"-9	-	-	-
25 x 20	M30	-	-	-	-	-	-	-	-	-	-	-
28 x 22.4	M33	-	1 1/2"-4	-	1 1/2"-12	-	1 1/2"-7	-	1 1/2"-9	-	-	-
31.5 x 25	M36	-	1 3/8"-6	-	1 3/8"-12	-	-	-	1 3/8"-8	-	-	-
	M39	-	1 1/2"-6	-	1 1/2"-12	-	1 1/2"-6	-	1 1/2"-8	-	-	-
	M42	-	-	-	-	-	-	-	1 3/8"-8	-	-	-
	M45	-	1 3/4"-5	-	-	-	1 3/4"-5	-	1 3/4"-7	-	-	-
	M48	-	-	-	-	-	-	-	-	-	-	-

Tap Shank Dimension DIN

Dimension Dia. x Square	DIN 352	DIN 353	DIN 371	DIN 374	DIN 376	DIN 2182	DIN 2183
3.5 x 2.7	M3	-	M3	M5	M5	1/8"	-
4 x 3	M4	-	M3.5	-	-	-	-
4.5 x 3.4	M4	-	M4	M6	M6	5/32"	1/4"
	M5	-	M5	-	-	7/32"	-
6 x 4.9	M6	-	M6	-	-	-	-
	M8	-	-	M8	M8	-	-
7 x 5.5	M10	G 1/8"	-	M10	M10	1/4"	3/8"
8 x 6.2	-	-	M8	-	-	5/16"	7/16"
9 x 7	M12	-	-	M12	M12	3/8"	1/2"
10 x 8	-	-	M10	-	-	-	-
11 x 9	M14	G 1/4"	-	M14	M14	-	9/16"
12 x 9	M16	G 3/8"	-	M16	M16	-	5/8"
14 x 11	M18	-	-	M18	M18	-	11/16"
16 x 12	M20	G 1/2"	-	M20	M20	-	13/16"
18 x 14.5	M22	G 5/8"	-	M22	M22	-	7/8"
	M24	-	-	M24	M24	-	15/16"
20 x 16	M27	G 3/4"	-	M27	M27	-	1"
22 x 18	M30	G 7/8"	-	M30	M30	-	1 1/8"
26 x 20	M33	G 1"	-	M33	M33	-	1 1/2"
28 x 22	M36	G 1 1/8"	-	M36	M36	-	1 3/8"
32 x 24	M39	G 1 1/8"	-	M39	M39	-	1 1/2"
	M42	-	-	M42	M42	-	1 3/8"
36 x 29	M45	G 3/4"	-	M45	M45	-	1 3/4"
	M48	G 1 1/2"	-	M48	M48	-	1 7/8"
	-	G 1 3/4"	-	-	-	-	-
	-	G 2"	-	-	-	-	-

Tap Shank Dimensions

ANSI (US Standards)

Tap Shank Dimensions (JIS Standards)

Dimension in Inch. Dia. x Square		Metric Conversions		Tap Size	Dimension in Inch. Dia. x Square		Metric Conversions		Tap Size	Dimension in mm. Dia. x Square		Tap Size
0.141	0.110	3.59	2.80	1/8" No.6	0.590	0.442	14.99	11.23	3/4"	4.0	3.0	M 3 & M 3.5
0.168	0.131	4.27	3.33	5/32" No.8	0.652	0.489	16.57	12.43	M 20	5.0	4.0	M 4 & M 4.5
0.194	0.152	4.93	3.87	3/16" No. 10	0.688	0.515	17.47	13.09	1/2" Ps	5.5	4.5	M 5
0.220	0.165	5.59	4.20	No. 12	0.697	0.523	17.71	13.29	7/8"	6.0	4.5	M 6
0.255	0.191	6.48	4.86	1/4" No. 14	0.700	0.531	17.78	13.49	3/8"Ps	6.2	5.0	M 7 & M 8
0.312	0.234	7.94	5.95	1/16"Ps 1/8"Ps	0.760	0.570	19.31	14.48	M 24	7.0	5.5	M 9 & M 10
0.318	0.238	8.08	6.05	5/16" 3/8"	0.800	0.600	20.32	15.24	1"	8.0	6.2	M 11
0.323	0.242	8.21	6.15	5/16" 7/16"	0.896	0.672	22.76	17.07	1 1/8"	8.5	6.5	M 12
0.367	0.275	9.33	6.99	1/2"	0.906	0.679	23.02	17.25	3/4" P	10.5	8.0	M 14
0.381	0.286	9.68	7.27	3/8"	1.021	0.766	25.94	19.46	1 1/2"	12.5	10.0	M 16
0.429	0.322	10.90	8.18	9/16"	1.108	0.833	28.15	21.11	1 3/8"	14.0	11.0	M 18
0.438	0.328	11.12	8.34	1/8"Ps	1.125	0.843	28.58	21.42	1" P	15.0	12.0	M 20
0.480	0.360	12.20	9.15	5/8"	1.233	0.925	31.32	23.50	1 1/2"	17.0	13.0	M 22
0.542	0.406	13.77	10.31	11/16"	1.132	0.984	33.34	25.00	1 1/4" P	19.0	15.0	M 24
0.563	0.421	14.29	10.70	1/4"Ps	1.430	1.072	36.33	27.23	1 3/4"	20.0	15.0	M 27
										23.0	23.17	M 30

TAP MASCHIO	TORQUE - MOMENTO TORCENTE Nm				
	IBS 0	IBS 1	IBS 2	IBS 3	IBS 4
M2	0,6	0,6	-	-	-
M3	1	1	-	-	-
M3,5	1,5-2	1,5-2	-	-	-
M4	1,8-3	1,8-3	-	-	-
M5	3,5-5,5	3,5-5,5	-	-	-
M6-M7	5,5-9	5,5-9	5,5-9	-	-
M8-M9	14-18	14-18	14-18	-	-
M10-M11	21-25	21-25	21-25	-	-
M12	21-25	33-39	33-39	33-39	-
M14	-	45-50	45-50	45-50	-
M16	-	45-50	50-57	45-50	-
M18	-	-	80-87	80-87	-
M20	-	-	90-100	90-100	90-100
M22	-	-	100-110	100-110	100-110
M24	-	-	100-110	140-150	140-150
M27	-	-	-	150-160	150-160
M30	-	-	-	240-250	240-250
M33	-	-	-	260-270	260-270
M36	-	-	-	260-270	350-400
M39	-	-	-	260-270	380-430
M42	-	-	-	-	500-550
M45	-	-	-	-	550-600
M48	-	-	-	-	630-680
M52	-	-	-	-	-



- Mit den hier aufgeführten Werten sind alle unsere SWE's voreingestellt. Sollten Sie einmal eine andere Einstellung wünschen, so wollen Sie dies bitte bei Bestellung angeben.



- The calibration values shown in the table are the average values produced during testing. Alternative calibration values should be requested when placing the order.



- Значения по калибровке, указанные в таблице, являются усредненными, полученными во время тестирования. Если нужны другие значения, указывайте при заказе.



- Les valeurs de tarage indiqués sur le tableau sont les valeurs réalisées pendant le montage. Pour tarages différents est nécessaire l'indiquer sur la commande.



- I valori in tabella sono quelli realizzati in fase di montaggio. Per tarature diverse siete pregati di farne richiesta al momento dell'ordine.



- 表格中显示的校对数值是测量中产生的平均值。如需其他校对值可在下单时提出要求。

ER TYP SPANNZANGEN PINCES TYPE ER
COLLETS ER TYPE PINZE TIPO ER
НАБОРЫ ЦАНГ ER ER 类型的夹头

DIN 6499/R

RUNOUT ≤ 0,010

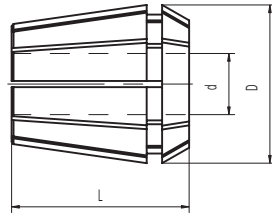

Type	D	L	Clamping capacity	Clamping range	DIN
ER8D..	8.5	13.5	1÷5	mm 0,5	4004E
ER11D..	11.5	18	1÷7	mm 0,5	4008E
ER16D..	17	27.5	1÷3 4÷10	mm 0,5 mm 1,0	426E
ER20D..	21	31.5	1÷3 4÷13	mm 0,5 mm 1,0	428E
ER25D..	26	34.5	1÷3 4÷16	mm 0,5 mm 1,0	430E
ER32D..	33	40	2÷20	mm 1,0	470E
ER40D..	41	46	3÷30	mm 1,0	472E
ER50D..	52	60	6÷34	mm 2,0	477E

ER - SPANNZANGENSATZ JEUX DE PINCES TYPE ER
ER COLLET SETS SERIE PINZE TIPO ER
НАБОРЫ ЦАНГ ER ER 夹头组套

RUNOUT ≤ 0,010



Type	Number of collets	Clamping capacity
SERIE-ER8	(1÷5) 9 collets	Ø 1-1,5-2-2,5-3-3,5-4-4,5-5
SERIE-ER11	(1÷7) 13 collets	Ø 1-1,5-2-2,5-3-3,5-4-4,5-5-5,5-6-6,5-7
SERIE-ER16	(1÷10) 10 collets	Ø 1-2-3-4-5-6-7-8-9-10
SERIE-ER20	(2÷13) 12 collets	Ø 2-3-4-5-6-7-8-9-10-11-12-13
SERIE-ER25	(2÷16) 15 collets	Ø 2-3-4-5-6-7-8-9-10-11-12-13-14-15-16
SERIE-ER32	(3÷20) 18 collets	Ø 3-4-5-6-7-8-9-10-11-12-13-14-15-16-17-18-19-20
SERIE-ER40	(4÷26) 23 collets	Ø 4-5-6-7-8-9-10-11-12-13-14-15-16-17-18-19-20-21-22-23-24-25-26
SERIE-ER40C	(3÷30) 26 collets	Ø 3-4-5-6-7-8-9-10-11-12-13-14-15-16-17-18-19-20-21-22-23-24-25-26-27-28-29-30

HOCHPRÄZISIONS-ER SPANNZANGEN ER PINCE DE HAUTE PRECISION
 HIGH PRECISION ER COLLETS PINZE ER DI ALTA PRECISIONE
 ВЫСОКОТОЧНЫЕ ЦАНГИ ER 高精度 ER 夹头

DIN 6499/B

RUNOUT ≤ 0,005

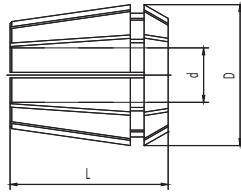

Type	D	L	Clamping capacity
ER 8 HP	8,5	13,5	1÷5
ER11 HP	11,5	18	1÷7
ER16 HP	17	27,5	1÷10
ER20 HP	21	31,5	1÷13
ER25 HP	26	34	1÷16
ER32 HP	33	40	2÷20
ER40 HP	41	46	3÷30
ER50 HP	52	60	6÷34

HOCHPRÄZISIONS-ER SPANNZANGENSÄTZE (Reduzierte Version) JEUX REDUITS DE PINCES ER DE HAUTE PRECISION
 REDUCED SETS OF COLLETS ER-HP TYPE SERIE RIDOTTA DI PINZE ER-HP
 СОКРАЩЕННЫЕ НАБОРЫ ВЫСОКОТОЧНЫХ ЦАНГ ER ER-HP 夹头筒装版

RUNOUT ≤ 0,005

Type	Diameters	No. collets
SERIE-ER 8 HP	1-2-3-4-5	5
SERIE-ER11 HP	1-2-3-4-5-6-7	7
SERIE-ER16 HP	2-4-6-8-10	5
SERIE-ER20 HP	2-4-6-8-10-12	6
SERIE-ER25 HP	4-6-8-10-12-16	6
SERIE-ER32 HP	4-6-8-10-12-16-20	7
SERIE-ER40 HP	4-6-8-10-12-16-20-25	8



HOCHPRÄZISIONS-ER SPANNZANGENSÄTZE (Komplette Version) JEUX COMPLETS DE PINCES ER DE HAUTE PRECISION
 COMPLETE SETS OF COLLETS ER-HP TYPE SERIE COMPLETA DI PINZE ER-HP
 ПОЛНЫЕ НАБОРЫ ВЫСОКОТОЧНЫХ ЦАНГ ER ER-HP 夹头的完整版

RUNOUT ≤ 0,005

Type	Diameters	No. collets
SERIE-ER 8 HPC	1÷5	9
SERIE-ER11 HPC	1÷7	13
SERIE-ER16 HPC	1÷10	10
SERIE-ER20 HPC	2÷13	12
SERIE-ER25 HPC	2÷16	15
SERIE-ER32 HPC	3÷20	18
SERIE-ER40 HPC	4÷26	23



ER-SPANNZANGEN ABGEDICHTET PINCES ER ETANCHES
 WATERTIGHT ER COLLETS PINZE ER A TENUTA STAGNA
 ЦАНГИ ER ДЛЯ ВНУТРЕННЕЙ ПОДАЧИ СОЖ 水密性 ER 夹头

DIN 6499/A

RUNOUT ≤ 0,010

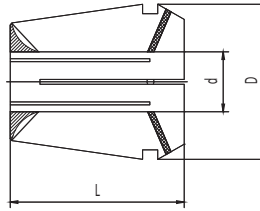

Type	D	L	Clamping capacity	Progressione
ER11VG	11.5	18	1÷7	0,5
ER16VG	17	27,5	1÷10	0,5
ER20VG	21	31,5	3÷13	0,5
ER25VG	26	34	2÷16	0,5
ER32VG	33	40	3÷20	0,5
ER40VG	41	46	4÷26	0,5

ER VG SPANNZANGENSÄTZE (Reduzierte Version) JEUX REDUITS DE PINCES ER VG
 REDUCED SETS OF COLLETS VG TYPE SERIE RIDOTTA DI PINZE VG
 СОКРАЩЕННЫЕ НАБОРЫ ЦАНГ ER ДЛЯ ВНУТРЕННЕЙ ПОДАЧИ СОЖ VG 型夹头简装版

RUNOUT ≤ 0,010

Type	Diameters	No. collets
SERIE-ER16VG	4-6-8-10	4
SERIE-ER20VG	4-6-8-10-12	5
SERIE-ER25VG	4-6-8-10-12-16	6
SERIE-ER32VG	4-6-8-10-12-16-20	7
SERIE-ER40VG	4-6-8-10-12-16-20-25	8



ER VG SPANNZANGENSÄTZE (Komplette Version) JEUX COMPLETS DE PINCES ER VG
 COMPLETE SETS OF COLLETS VG TYPE SERIE COMPLETA DI PINZE VG
 ПОЛНЫЕ НАБОРЫ ЦАНГ ER ДЛЯ ВНУТРЕННЕЙ ПОДАЧИ СОЖ VG 型夹头完整版

RUNOUT ≤ 0,010

Type	Diameters	No. collets
SERIE-ER16VG-C	3÷10	8
SERIE-ER20VG-C	3÷13	11
SERIE-ER25VG-C	3÷16	14
SERIE-ER32VG-C	3÷20	18
SERIE-ER40VG-C	4÷26	23



DICHTE ER-SPANNZANGE
ULTRA PRECISION WATERTIGHT ER COLLETS
ВЫСОКОТОЧНЫЕ ЦАНГИ ER ДЛЯ ВНУТРЕННЕЙ ПОДАЧИ СОЖ

PINCES ER ETANCHES
PINZE ER A TENUTA STAGNA DI ULTRA PRECISIONE
超高精度水密性 ER 夹头

DIN 6499/A

RUNOUT ≤ 0,005

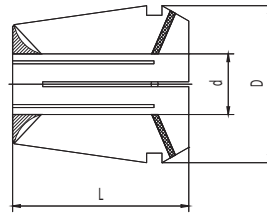

Type	D	L	Clamping capacity	Progressione
ER11VG-HP	11.5	18	1÷7	0,5
ER16VG-HP	17	27,5	3÷10	1
ER20VG-HP	21	31,5	3÷13	1
ER25VG-HP	26	34	2÷16	1
ER32VG-HP	33	40	3÷20	1
ER40VG-HP	41	46	4÷26	1

Spannzangen mit den gleichen Eigenschaften wie die abgedichteten aber mit Hochpräzision und Rundlauf < 0,0005. Arbeitsdruck: max. 40 Bar/600 PSI. Diese Spannzangen spannen nur den Nenndurchmesser.

Collets with the same characteristics of VG type but with an ultra precision <0.005 runout accuracy. Working pressure: max 40Bar/600 PSI. Those collets clamp only nominal diameter.

Цанги с такими же характеристиками, как у обычных цанг для внутреннего подвода СОЖ, но с меньшим биением <0,005. Рабочее давление: макс. 40 бар/600 фунт сил. Данные цанги существуют только номинального диаметра.

Pinces avec les mêmes caractéristiques des pinces étanches mais ultra-précises avec concentricité < 0,005. Pression de service : max 40 Bar/600 PSI. Ces pinces bloquent seulement le diamètre nominal.

Pinze con le medesime caratteristiche delle VG ma di altissima precisione concentricità <0,005 mm. Pressione di esercizio: max 40 Bar/600 PSI. Bloccano solo il diametro nominale.

这些夹头与 VG 类型的夹头的特点相同，但精度超高，径向跳动精度 <0.005。工作压力：最高为 40Bar/600 PSI。这些夹头只能用于夹持常规直径。

ER VG UP SPANNZANGENSÄTZE (Reduzierte Version)
REDUCED SETS OF COLLETS VG-UP TYPE
СОКРАЩЕННЫЕ НАБОРЫ ВЫСОКОТОЧНЫХ ЦАНГ ER ДЛЯ ВНУТРЕННЕЙ ПОДАЧИ СОЖ

JEUX REDUITS DE PINCES ER VG UP
SERIE RIDOTTA DI PINZE VG-UP
VG - UP 型夹头筒装版

RUNOUT ≤ 0,005

Type	Diameters	No. collets
SERIE-ER16VG-HP	4-6-8-10	4
SERIE-ER20VG-HP	4-6-8-10-12	5
SERIE-ER25VG-HP	4-6-8-10-12-16	6
SERIE-ER32VG-HP	4-6-8-10-12-16-20	7
SERIE-ER40VG-HP	4-6-8-10-12-16-20-25	8



ER VG UP SPANNZANGENSÄTZE (Komplette Version)
COMPLETE SETS OF COLLETS VG-UP TYPE
ПОЛНЫЕ НАБОРЫ ВЫСОКОТОЧНЫХ ЦАНГ ER ДЛЯ ВНУТРЕННЕЙ ПОДАЧИ СОЖ

JEUX COMPLETS DE PINCES ER VG UP
SERIE COMPLETA DI PINZE VG-UP
VG - UP 型夹头完整版

RUNOUT ≤ 0,005

Type	Diameters	No. collets
SERIE-ER16VG-HPC	3÷10	8
SERIE-ER20VG-HPC	3÷13	11
SERIE-ER25VG-HPC	3÷16	14
SERIE-ER32VG-HPC	3÷20	18
SERIE-ER40VG-HPC	4÷26	23



ER TYP SPANNZANGEN MIT INNENVERIANT
 ER TAPPING COLLETS WITH SQUARE
 ЦАНГИ ER С КВАДРАТОМ
 PINCES DE TARAUDAGE
 PINZE ER CON QUADRO PER MASCHIATURA
 ER 粗丝锥夹头

DIN 6499/A

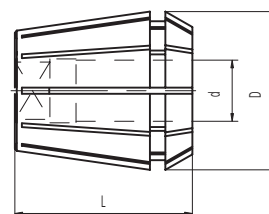

Type	D	L	Clamping capacity
ER16MD..	17	27.5	3.5÷8
ER20MD..	21	31.5	3.5÷10
ER25MD..	26	34	3.5÷12
ER32MD..	33	40	3.5÷16
ER40MD..	41	46	4.5÷20

TECHNISCHE DATEN
 TECHNICAL INFORMATION
 ТЕХНИЧЕСКАЯ ИНФОРМАЦИЯ
 DONNÉES TECHNIQUES
 INFORMAZIONI TECNICHE
 技术信息

TAPE MASCHIO M	SHANK - GAMBO	
	Ø D	SQ
M3	3,5	2,7
M3,5	4	3
M4	4,5	3,4
M4	5	4
M5	5,5	4,3
M5	6	4,9
M6	6	4,9
M6	6,3	5
M8	6	4,9
M8	6,3	5
M7	7	5,5
M10	7	5,5
M8	8	6,2
M9	9	7

TAPE MASCHIO M	SHANK - GAMBO	
	Ø D	SQ
M12	9	7
M10	10	8
M14	11	9
M14	11,2	9
M16	12	9
M16	12,5	10
M18	14	11
M20	16	12
M24	18	14,5
M27	20	16
M30	22	18
M33	25	20
M36	28	22
M39-42	32	24

EOC TYP SPANNZANGEN
COLLETS EOC TYPE
ЦАНГИ EOC
PINCES TYPE EOC
PINZE TIPO EOC
EOC 夹头

DIN 6388

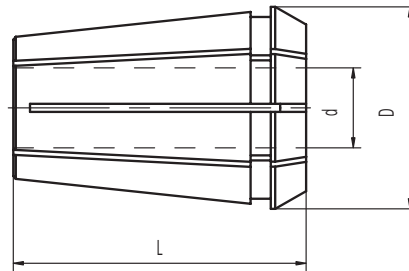

Type	D	L	Clamping capacity	DIN	Progressione
EOC16D..	25,50	40	2÷16	415E	mm 0,5
EOC25D..	35,05	52	2÷25	462E	mm 0,5
EOC32D..	43,70	60	3÷32	467E	mm 0,5

ABGEDICHTETE SPANNZANGEN FÜR HYDRODEHNSPANNFUTTER
COLLETS FOR HYDRAULIC CHUCKS
ЦАНГИ ДЛЯ ГИДРАВЛИЧЕСКИХ ПАТРОНОВ
PINCES POUR MANDRINS HYDRAULIQUES
PINZE PER MANDRINI IDRAULICI
液压卡盘夹头

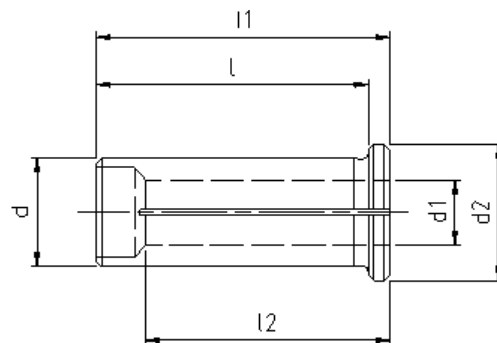

Type	D1	D2	L1	L2	D hole size
GX12D..	12	16	36	40	3;4;5;6;8
GX20D..	20	25	50	54	3;4;5;6;8;10;12;14;16
GX32D..	32	36	60	64	6;8;10;12;14;16;18;20;25

KÜHLMITTEL BIS 80 BAR • COOLANT RESISTANT UP TO 80 BAR
ПОДВОД СОЖ ДО 80 БАР • LUBRIFIANT JUSQU'À 80 BAR.
REFRIGERANTE RESISTENTE FINO A 80 BAR • 耐冷却液值达80杆

SPANNZANGEN FÜR KRAFTSPANNFUTTER
COLLETS FOR MILLING CHUCK
ЦАНГИ ДЛЯ УСИЛЕННЫХ ПАТРОНОВ

PINCES POUR MANDRINS A FORT SERRAGE
PINZE PER MANDRINI A FORTE SERRAGGIO
铣夹头用夹头

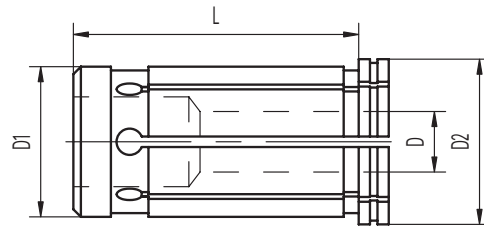

Type	D1	D2	L	D hole size
K20D..	20	25	50	3;4;5;6;8;10;12;14;16
K32D..	32	37	60	6;8;10;12;14;16;18;20;25



KONSTRUKTIONSDATEN:

- für Werkzeuge mit Schaft Toleranz h6;
- sehr hohe Maß- und Formgenauigkeit;
- Max. Rundlauffehler zwischen D und D1 - 0,005 mm.



MANUFACTURING SPECIFICATIONS

- For tool shank tolerance h6
- Maximum form and dimensional precision
- Max concentricity error between D and D1: 0,005mm.



СТРОИТЕЛЬСТВО ХАРАКТЕРИСТИКИ

- Для инструментов с допуском h6 на хвостовик
- Максимальная точность форм и размеров
- Максимальное биение диаметра D относительно D1: 0.005мм



CARACTÉRISTIQUES CONSTRUCTIVES:

- pour outils avec queue en tolérance h6;
- très haute précision dimensionnelle et de forme;
- erreur maximale de concentricité entre D et D1 - 0,005 mm.



CARATTERISTICHE COSTRUTTIVE

- Per utensili con gambo in tolleranza h6
- Altissima precisione dimensionale e di forma
- Max errore di concentricità tra D e D1 - 0,005 mm.



施工特点

- 刀柄公差为H6
- 最大结构和尺寸精度
- 与D1之间最大同心度误差: 0.005mm

SPANNSCHLÜSSEL FÜR MINI SPANNMUTTER
WRENCHES FOR MINI NUT
КЛЮЧИ ДЛЯ МИНИ-ГАЕК

CLES DE SERRAGE POUR ECROU MINI
CHIAVI PER GHIERA MINI
微型螺母用扳手

Code N.	ER	d	L
816-203007	8M	12,4	70
816-203008	11M	16,8	90
816-203009	16M	22,5	110
816-203010	20M	29	120
816-203011	25M	36	130

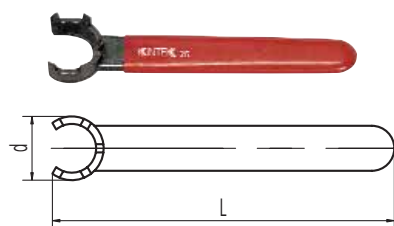

SPANNSCHLÜSSEL FÜR FRÄSERANZUGSSCHRAUBEN
WRENCHES FOR TOOLS RETAINING SCREW
НАКИДНЫЕ КЛЮЧИ ДЛЯ КРЕСТОБРАЗНЫХ ВИНТОВ

CLE A VIS A CROSSE
CHIAVE PER VITE TESTA A CROCE
使螺丝保持就位工具用扳手

Code N.	Size	d	L
816-130002	16/M08	22	180
816-130003	22/M10	28	200
816-130004	27/M12	35	225
816-130005	32/M16	42	250
816-130006	40/M20	52	280
816-130007	50/M24	63	315

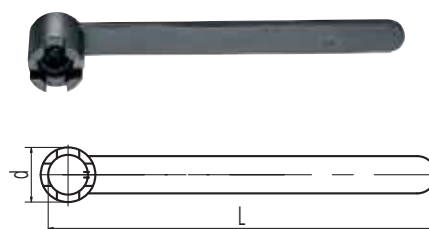

SPANNSCHLÜSSEL FÜR ÜBERWURFMUTTERN
WRENCHES FOR LOCKNUT
ПОВОРОТНЫЕ КЛЮЧИ

CLES POUR COLLIERE D'ETANCHEITE
CHIAVI PER GHIERA DI TENUTA
自锁螺母用扳手

Code N.	Size	d	L
816-20204002	M10/MK1	9,9	85
816-20205002	M15/MK2	14,8	110
816-20206002	M20/MK3	19,2	115
816-20207002	M24/MK4	23	140
816-20208002	M36/MK5	37	172

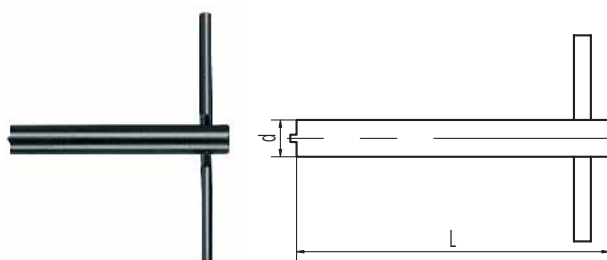

SPANNSCHLÜSSEL FÜR KÜHLMITTELÜBERGABESATZ
KEY FOR COOLANT SUPPLY UNIT
КЛЮЧИ ДЛЯ ВИНТОВ, НАПРАВЛЯЮЩИХ СОЖ

CLES POUR LE DISPOSITIF DE TRANSFERT DE LIQUIDE DE LUBRIFICATION
CHIAVE PER ADDUTTORE REFRIGERANTE
冷却剂供应装置键

HSK	Code N.
40	816-204022
63	816-204024
100	816-204025

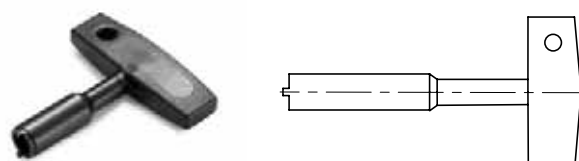

KREUZKOPFSCHRAUBEN FÜR AUFSTECKFRASDORNE
UND KOMBI-AUFSTECKFRASDORNE
CROSS HEAD SCREW FOR FACE MILL HOLDERS
AND COMBI-SHELL MILL ADAPTORS
КРЕСТООБРАЗНЫЕ ВИНТЫ К ОПРАВКАМ ДЛЯ НАСАДНЫХ ФРЕЗ

VIS CRUCIFORMES POUR PORTE-FRAISES
FIXES ET COMBINÉS
VITI TESTA CROCE PER PORTAFRESE
FISSI E COMBINATI
平面铣夹具和复合式平面铣接头十字头螺丝

Code N.	M	D	L1	L2	Type
811-107003	M8	20	16	6	A
811-107004	M10	28	18	7	A
811-107005	M12	35	22	8	A
811-107006	M16	42	26	9	A
811-107007	M20	52	30	10	A
811-107009	M24	63	36	12	A
811-107013	M8	20	16	6	B
811-107014	M10	28	18	7	B
811-107015	M12	35	22	8	B
811-107016	M16	42	26	9	B
811-107017	M20	52	30	10	B
811-107027	M24	63	36	12	B



Type A

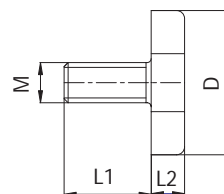

Type B

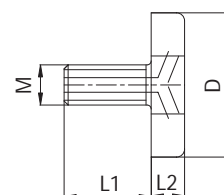

GEWUCHTETE SPANNMUTTER
BALANCED NUT
СБАЛАНСИРОВАННЫЕ ГАЙКИ

ECROU EQUILIBRE
GHIERA BILANCIATA STANDARD
平衡螺母

DIN 6499

Code N.	ER	D	L	M
812-203005	16	32	18	M22X1,5
812-203006	20	35	19	M25X1,5
812-203001	25	42	20	M32X1,5
812-203002	32	50	22.5	M40X1,5
812-203003	40	63	25.5	M50X1,5



SPANNSCHLÜSSEL FÜR STANDARD SPANNMUTTER
WRENCHES FOR STANDARD NUT
КЛЮЧИ ДЛЯ СТАНДАРТНЫХ ГАЕК

CLES DE SERRAGE POUR ECROU STANDARD
CHIAVI PER GHIERA STANDARD
标准螺母用扳手

Code N.	ER	A	L
816-203000	16	54	165
816-203005	20	60	180
816-203001	25	70	200
816-203002	32	80	250
816-203003	40	95	280

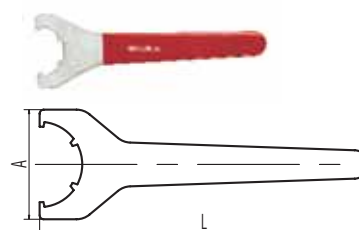

MINI SPANNMUTTER
MINI NUT
МИНИ-ГАЙКИ
ECROU MINI
GHIERA MINI
微型螺母

DIN 6499

Code N.	ER	D	L	M
812-203011	8M	12	11	M10X0,75
812-203012	11M	16	12	M13X0,75
812-203013	16M	22	18	M19X1
812-203014	20M	28	19	M24X1
812-203015	25M	35	20	M30X1



EOC SPANNMUTTER
EOC NUT
ГАЙКИ EOC
ECROU EOC
GHIERA EOC
EOC 螺母

DIN 6388

Code N.	EOC	D	L	M
GOC16	16	43	24	M33X1,5
GOC20	20	50	28	M42X2
GOC25	25	60	30	M48X2
GOC32	32	72	34	M60X2,5



GEWUCHTETE SPANNMUTTER
BALANCED NUT
СБАЛАНСИРОВАННЫЕ ГАЙКИ
ECROU EQUILIBRÉ
GHIERA BILANCIATA
平衡螺母

DIN 6499

Code N.	ER	D	L	M
812-203069	16	32	18	M22x1,5
812-203070	25	42	20	M32x1,5
812-203071	32	50	22,5	M40x1,5
812-203072	40	63	25,5	M50x1,5



* Für Aufnahmen mit 25.000 U/m G2,5 Wuchtung

* For balanced toolholders, G2,5 25000 RPM

* Для сбалансированных оправок с классом G2,5 при 25000 об/мин

* Pour mandrins équilibrés a 25.000 tours G2,5

* Per mandrini bilanciati in classe G2,5 25000 RPM

* 用于平衡刀柄G2.5 25000 RPM

SPANNSCHLÜSSEL
WRENCHES FOR BALANCED NUTS
КЛЮЧИ ДЛЯ СБАЛАНСИРОВАННЫХ ГАЕК
CLES DE SERRAGE
CHIAVI PER GHIERE BILANCIATE
平衡螺母扳手

Code N.	Type	ER	Dimension
816-203031	-	16	30/32
816-203032	-	25	40/42
816-203033	GOC 16/20	32	45/50
816-203034	GOC 25	40	58/62
816-203036	GOC 32	-	68/75



KEGELWISCHER
TAPER WIPERS
ПРОТИРОЧНЫЕ КОНУСЫ

CONES DE NETTOYAGE
PULITORI PER CONI
锥形刷



Code N.	
832-021100	HSK40
832-021101	HSK50
832-021102	HSK63
832-021099	HSK100



Code N.	
832-021103	MK1
832-021104	MK2
832-021105	MK3
832-021106	MK4
832-021107	MK5



Code N.	
832-021108	SK30
832-021109	SK40
832-021110	SK50

SPANNBOLZEN DIN 69872 TIRETTES DIN 69872
 DIN 69872 PULL STUDS CODOLI DI AGGANCIO DIN 69872
 ТЯНУЩИЕ ШТАНГИ DIN 69872 DIN 69872 拉动式双头螺柱

DIN 69872

Ohne Bohrung • *Not drilled* • Non Percée • *Non forato* • *Без отверстия* • 未钻孔的

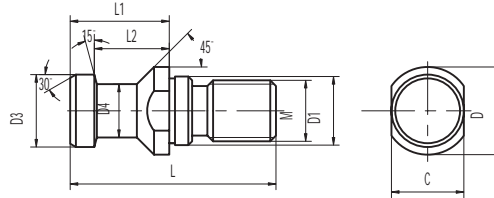

DIN 69872 B

Code N.	ISO	M	D	D1	D3	D4	L	L1	L2	C
217-21206	30	M12	17	13	13	9	44	24	19	14
217-21207	40	M16	23	17	19	14	54	26	20	19
217-21208	50	M24	36	25	28	21	74	34	25	30

Ohne Bohrung • *Not drilled* • Non Percée • *Non forato* • *Без отверстия* • 未钻孔的
 Mit O'Ring • *With O'ring* • Avec joint torique • *Con OR di tenuta* • *С кольцом* • 带O'令

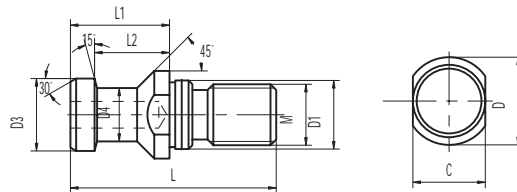

DIN 69872 B

Code N.	ISO	M	D	D1	D3	D4	L	L1	L2	C
217-21301	40	M16	23	17	19	14	54	26	20	19
217-21302	50	M24	36	25	28	21	74	34	25	30

Gebohrt • *Drilled* • Percée • *Forato* • *С отверстием* • 钻孔的

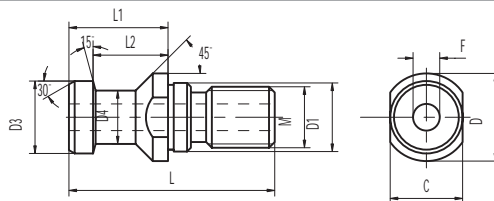

DIN 69872 A

Code N.	ISO	M	D	D1	D3	D4	L	L1	L2	C	f
217-21201	40	M16	23	17	19	14	54	26	20	19	7
217-21202	50	M24	36	25	28	21	74	34	25	30	11,5

SPANNBOLZEN DIN 69872 TIRETTES DIN 69872
 DIN 69872 PULL STUDS CODOLI DI AGGANCIO DIN 69872
 ТЯНУЩИЕ ШТАНГИ DIN 69872 DIN 69872 拉动式双头螺柱

DIN 69872

Gebohrt • Drilled • Percée • Forato • С отверстием • 钻孔的
 Mit O'Ring • With O'ring • Avec joint torique • Con OR di tenuta • С кольцом • 带O'令

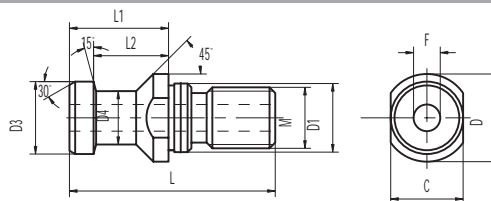

DIN 69872 A

Code N.	ISO	M	D	D1	D3	D4	L	L1	L2	C	f
217-21305	40	M16	23	17	19	14	54	26	20	19	7
217-21306	50	M24	36	25	28	21	74	34	25	30	11,5

ABGEDICHTETE ANZUGSBOLZEN MIT DOPPELTEM O-RING FÜR HOCHKÜHLMITTELDRUCK
 SEaled PULL STUDS WITH DOUBLE O-RING FOR HIGH PRESSURE COOLANT
 ШТРЕВЕЛЯ С ДВОЙНЫМ УПЛОТНИТЕЛЬНЫМ КОЛЬЦОМ ДЛЯ РАБОТЫ ПОД БОЛЬШИМ ДАВЛЕНИЕМ СОЖ
 TIRETTES ETANCHES AVEC DOUBLE O-RING POUR ARROSAGE A' HAUTE PRESSION
 CODOLI CON DOPPIO O-RING PER REFRIGERANTE AD ALTA PRESSIONE
 用于高压冷却剂带双O环的密封拉钉

DIN 69872

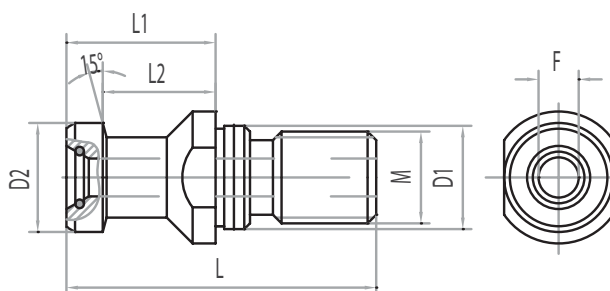

Code N.	ISO	M	D1	D2	L	L1	L2	F
217-21307	40	M16	17	19	54	26	20	7
217-21308	40	M16	17	19	54	29	23	7
217-21309	50	M24	25	28	74	34	25	11,5

SPANNBOLZEN ISO 7388/2-B TIRETTES ISO 7388/2-B
 ISO 7388/2-B PULL STUDS CODOLI DI AGGANCIAMENTO ISO 7388/2-B
 ТЯНУЩИЕ ШТАНГИ ISO 7388/2-B ISO 7388/2-B 拉动式双头螺柱

ISO 7388/2-B

Ohne Bohrung • Not drilled • Non Percée • Non forato • Без отверстия • 未钻孔的

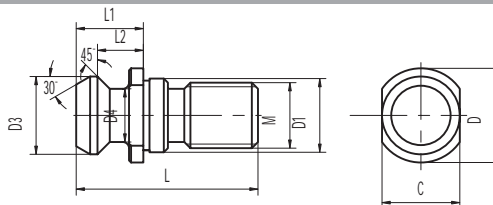

Code N.	ISO	M	D	D1	D3	D4	L	L1	L2	C
217-21607	30	M12	17	12,5	13,3	9,3	34	11,8	8,1	14
217-21608	40	M16	22,5	17	18,9	12,9	44,5	16,4	11,2	18
217-21609	50	M24	37	25	29,1	19,6	65,5	25,5	17,9	30

Ohne Bohrung • Not drilled • Non Percée • Non forato • Без отверстия • 未钻孔的
 Mit O'Ring • With O'ring • Avec joint torique • Con OR di tenuta • С кольцом • 带O'令

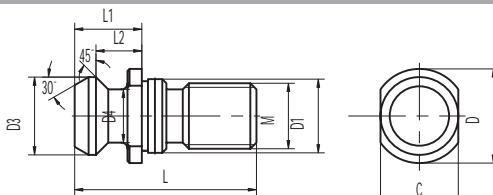

Code N.	ISO	M	D	D1	D3	D4	L	L1	L2	C
217-21611	40	M16	22,5	17	18,9	12,9	44,5	16,4	11,2	18
217-21612	50	M24	37	25	29,1	19,6	65,5	25,5	17,9	30

Gebohrt • Drilled • Percée • Forato • С отверстием • 钻孔的

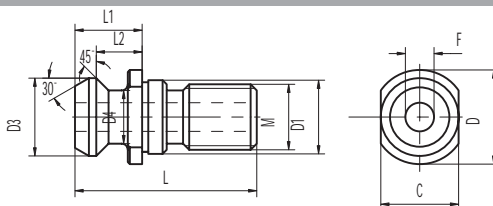

Code N.	ISO	M	D	D1	D3	D4	L	L1	L2	C	f
217-21601	40	M16	22,5	17	18,9	12,9	44,5	16,4	11,2	18	7,3
217-21602	50	M24	37	25	29,1	19,6	65,5	25,5	17,9	30	11,5

Gebohrt • Drilled • Percée • Forato • С отверстием • 钻孔的
 Mit O'Ring • With O'ring • Avec joint torique • Con OR di tenuta • С кольцом • 带O'令

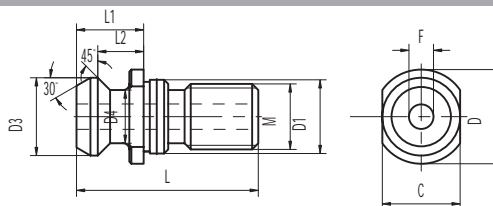

Code N.	ISO	M	D	D1	D3	D4	L	L1	L2	C	f
217-21621	40	M16	22,5	17	18,9	12,9	44,5	16,4	11,2	18	7,3
217-21622	50	M24	37	25	29,1	19,6	65,5	25,5	17,9	30	11,5

SPANNBOLZEN ISO 7388/2-A TIRETTES ISO 7388/2-A
 ISO 7388/2-A PULL STUDS CODOLI DI AGGANCIAMENTO ISO 7388/2-A
 ТЯНУЩИЕ ШТАНГИ ISO 7388/2-A ISO 7388/2-A 拉动式双头螺柱

ISO 7388/2-A

Ohne Bohrung • Not drilled • Non Percée • Non forato • Без отверстия • 未钻孔的

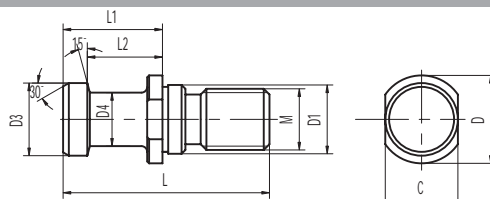

Code N.	ISO	M	D	D1	D3	D4	L	L1	L2	C
217-21616	30	M12	16	13	12	8	44	24	19	14
217-21617	40	M16	23	17	19	14	54	26	20	19
217-21618	50	M24	36	25	28	21	74	34	25	30

Ohne Bohrung • Not drilled • Non Percée • Non forato • Без отверстия • 未钻孔的
 Mit O'Ring • With O'ring • Avec joint torique • Con OR di tenuta • С кольцом • 带O'令

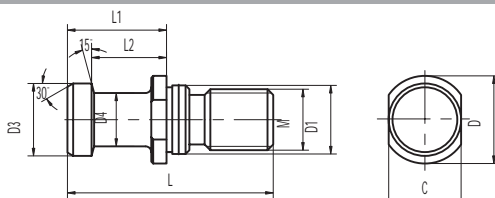

Code N.	ISO	M	D	D1	D3	D4	L	L1	L2	C
217-21619	40	M16	23	17	19	14	54	26	20	19
217-21620	50	M24	36	25	28	21	74	34	25	30

Gebohrt • Drilled • Percée • Forato • С отверстием • 钻孔的

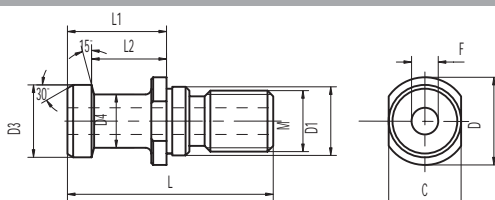

Code N.	ISO	M	D	D1	D3	D4	L	L1	L2	C	f
217-21614	40	M16	23	17	19	14	54	26	20	19	7
217-21615	50	M24	36	25	28	21	74	34	25	30	11

Gebohrt • Drilled • Percée • Forato • С отверстием • 钻孔的
 Mit O'Ring • With O'ring • Avec joint torique • Con OR di tenuta • С кольцом • 带O'令

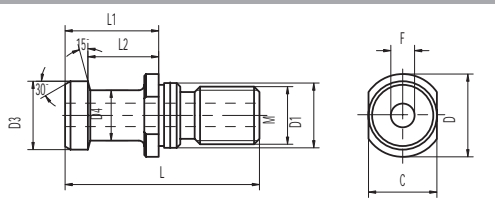

Code N.	ISO	M	D	D1	D3	D4	L	L1	L2	C	f
217-21623	40	M16	23	17	19	14	54	26	20	19	7
217-21624	50	M24	36	25	28	21	74	34	25	30	11,5

SPANNBOLZEN ISO MAS-BT TIRETTES MAS-BT
 MAS-BT PULL STUDS CODOLI DI AGGANCIO MAS-BT
 ТЯНУЩИЕ ШТАНГИ MAS-BT MAS-BT 拉动式双头螺柱

MAS-BT

Ohne Bohrung • Not drilled • Non Percée • Non forato • Без отверстия • 未钻孔的

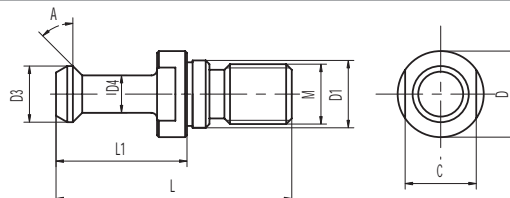

Code N.	ISO	A	M	L1	L	D	D1	D3	D4	C
217-21508	30	30°	M12	23	43	16	12,5	11	7	13
217-21507	30	45°	M12	23	43	16	12,5	11	7	13
217-21502	40	30°	M16	35	60	23	17	15	10	19
217-21501	40	45°	M16	35	60	23	17	15	10	19
217-21503	40	90°	M16	35	60	23	17	15	10	19
217-21505	50	30°	M24	45	85	38	25	23	17	30
217-21504	50	45°	M24	45	85	38	25	23	17	30
217-21506	50	90°	M24	45	85	38	25	23	17	30

Ohne Bohrung • Not drilled • Non Percée • Non forato • Без отверстия • 未钻孔的
 Mit O'Ring • With O'ring • Avec joint torique • Con OR di tenuta • С кольцом • 带O'令

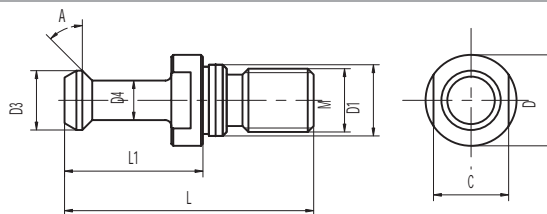

Code N.	ISO	A	M	L1	L	D	D1	D3	D4	C
217-21401	40	30°	M16	35	60	23	17	15	10	19
217-21402	40	45°	M16	35	60	23	17	15	10	19
217-21403	40	90°	M16	35	60	23	17	15	10	19
217-21404	50	30°	M24	45	85	38	25	23	17	30
217-21405	50	45°	M24	45	85	38	25	23	17	30
217-21406	50	90°	M24	45	85	38	25	23	17	30

Gebohrt • Drilled • Percée • Forato • С отверстием • 钻孔的

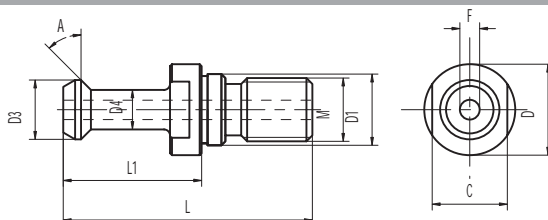

Code N.	ISO	A	M	L1	L	D	D1	D3	D4	C	F
217-22206	40	30°	M16	35	60	23	17	15	10	19	4
217-22207	40	45°	M16	35	60	23	17	15	10	19	4
217-22208	40	90°	M16	35	60	23	17	15	10	19	4
217-22209	50	30°	M24	45	85	38	25	23	17	30	6
217-22210	50	45°	M24	45	85	38	25	23	17	30	6
217-22211	50	90°	M24	45	85	38	25	23	17	30	6

SPANNBOLZEN MAS-BT TIRETTES MAS-BT
 MAS-BT PULL STUDS CODOLI DI AGGANCIAMENTO MAS-BT
 ТЯНУЩИЕ ШТАНГИ MAS-BT MAS-BT 拉动式双头螺柱

MAS-BT

Gebohrt • Drilled • Percée • Forato • С отверстием • 钻孔的
 Mit O'Ring • With O'ring • Avec joint torique • Con OR di tenuta • С кольцом • 带O'令

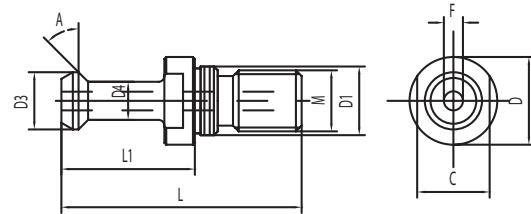

Code N.	ISO	A	M	L1	L	D	D1	D3	D4	C	F
217-22316	40	30°	M16	35	60	23	17	15	10	19	4
217-22317	40	45°	M16	35	60	23	17	15	10	19	4
217-22318	40	90°	M16	35	60	23	17	15	10	19	4
217-22319	50	30°	M24	45	85	38	25	23	17	30	6
217-22320	50	45°	M24	45	85	38	25	23	17	30	6
217-22321	50	90°	M24	45	85	38	25	23	17	30	6

ABGEDICHTETE ANZUGSBOLZEN MIT DOPPELTEM O-RING FÜR HOCHKÜHLMITTELDRUCK
 TIRETTES ETANCHES AVEC DOUBLE O-RING POUR ARROSAGE A' HAUTE PRESSION
 SEALED PULL STUDS WITH DOUBLE O-RING FOR HIGH PRESSURE COOLANT
 CODOLI CON DOPPIO O-RING PER REFRIGERANTE AD ALTA PRESSIONE
 ШТРЕВЕЛА С ДВОЙНЫМ УПЛОТНИТЕЛЬНЫМ КОЛЬЦОМ ДЛЯ РАБОТЫ ПОД БОЛЬШИМ ДАВЛЕНИЕМ СОЖ
 用于高压冷却剂带双O环的密封拉钉

MAS-BT

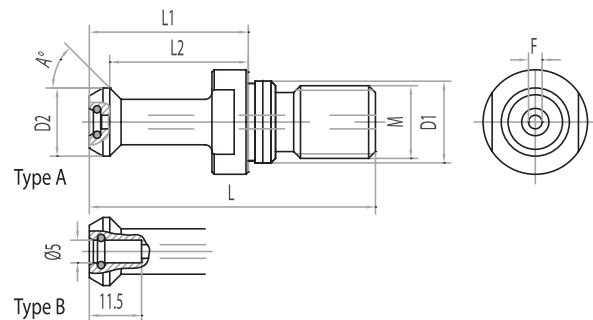

Code N.	ISO	A	M	L1	L2	L	D1	D2	F	Type
217-21410	40	45°	M16	35	28	60	17	15	3	A
217-21411	40	45°	M16	35	28	60	17	15	3	B
217-21412	50	45°	M24	45	35	85	25	23	6	A
217-21413	50	60°	M24	45	35	85	25	23	6	A
217-21414	50	90°	M24	45	35	85	25	23	6	A

SPANNBOLZEN MAS-BT->DIN 69871
 MAS-BT->DIN 69871 PULL STUDS
 ТЯНУЩИЕ ШТАНГИ MAS-BT -> DIN 69871

TIRETTES MAS-BT->DIN 69871
 CODOLI DI AGGANCIAMENTO MAS-BT->DIN 69871
 MAS-BT->DIN 69871 拉动式双头螺柱

MAS-BT->DIN 69871

Ohne Bohrung • Not drilled • Non Percée • Non forato • Без отверстия • 未钻孔的

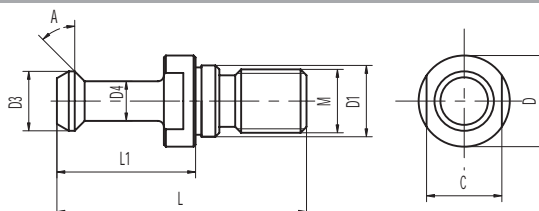

Code N.	ISO	A	M	L1	L	D	D1	D3	D4	C
217-22060	40	30°	M16	32	57	23	17	15	10	19
217-22090	40	45°	M16	32	57	23	17	15	10	19
217-22027	40	90°	M16	32	57	23	17	15	10	19

Ohne Bohrung • Not drilled • Non Percée • Non forato • Без отверстия • 未钻孔的
 Mit O'Ring • With O'ring • Avec joint torique • Con OR di tenuta • С кольцом • 帶O'令

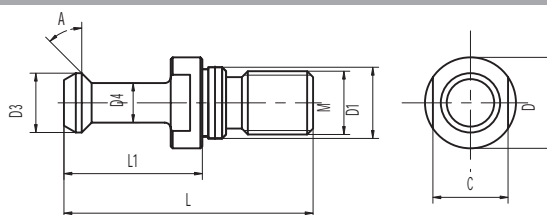

Code N.	ISO	A	M	L1	L	D	D1	D3	D4	C
217-21407	40	30°	M16	32	57	23	17	15	10	19
217-21408	40	45°	M16	32	57	23	17	15	10	19
217-21409	40	90°	M16	32	57	23	17	15	10	19

Gebohrt • Drilled • Percée • Forato • С отверстием • 钻孔的

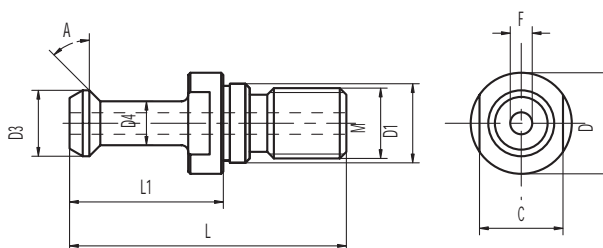

Code N.	ISO	A	M	L1	L	D	D1	D3	D4	C	F
217-22212	40	30°	M16	32	57	23	17	15	10	19	4
217-22213	40	45°	M16	32	57	23	17	15	10	19	4
217-22214	40	90°	M16	32	57	23	17	15	10	19	4

SPANNBOLZEN MAS-BT->DIN 69871
 MAS-BT->DIN 69871 PULL STUDS
 ТЯНУЩИЕ ШТАНГИ MAS-BT -> DIN 69871

TIRETTES MAS-BT->DIN 69871
 CODOLI DI AGGANCIAMENTO MAS-BT->DIN 69871
 MAS-BT->DIN 69871 拉动式双头螺柱

MAS-BT->DIN 69871

Geböhrt • Drilled • Percée • Forato • С отверстием • 钻孔的
 Mit O'Ring • With O'ring • Avec joint torique • Con OR di tenuta • С кольцом • 带O'令

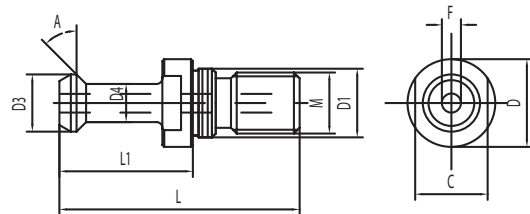

Code N.	ISO	A	M	L1	L	D	D1	D3	D4	C	F
217-22322	40	30°	M16	32	57	23	17	15	10	19	4
217-22323	40	45°	M16	32	57	23	17	15	10	19	4
217-22324	40	90°	M16	32	57	23	17	15	10	19	4

SPANNBOLZEN MIT RINGNUT NACH DIN 2080
 ADAPTOR PULL STUDS ACCORDING TO DIN 2080
 ПЕРЕХОДНИКИ К ТЯНУЩИМ ШТАНГАМ ПО DIN 2080

ADAPTATION SUIVANT DIN 2080
 CODOLO ADATTATORE DIN 2080
 符合 DIN 2080 标准的拉动式双头螺柱接头

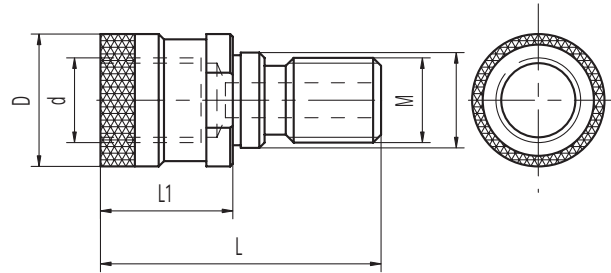

Code N.	ISO	M	d	D	D1	L	L1
217-22025	TC40	M16	M16	25.3	17	53	25
217-22040	BT40	M16	M16	25.3	17	56	28
217-22024	50	M24	M24	39,6	25	65	25

SPANNBOLZEN JIS. B6339
 JIS. B6339 PULL STUD
 ТЯНУЩИЕ ШТАНГИ ПО JIS. B6339

TIRETTE JIS. B6339
 CODOLO DI AGGANCIAMENTO JIS. B6339
 JIS. B6339* 双头螺柱

JIS. B6339

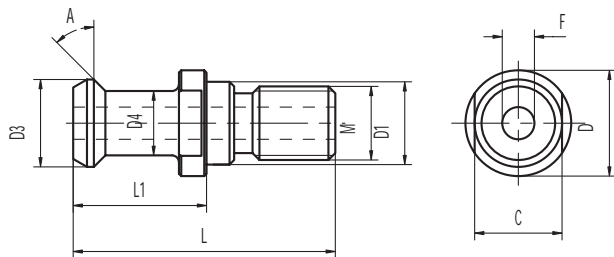

Code N.	ISO	A	M	D	D1	D3	D4	L	L1	C	F
217-22325	30	15°	M12	16,5	12,5	12	8	43	23,4	14	4
217-22134	40	15°	M16	23	17	19	14	54	29	19	7

Gebohrt • Drilled • Percée • Forato • С отверстием • 钻孔的

Gebohrt • Drilled • Percée • Forato • С отверстием • 钻孔的

Mit O'Ring • With O'ring • Avec joint torique • Con OR di tenuta • С кольцом • 带O'令

JIS. B6339

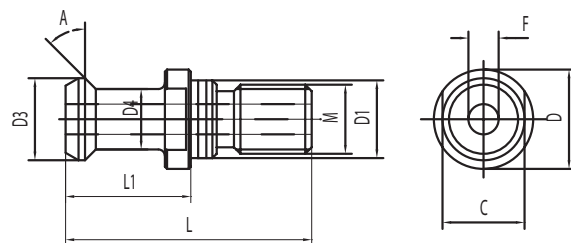

Code N.	ISO	A	M	D	D1	D3	D4	L	L1	C	F
217-22326	40	15°	M16	23	17	19	14	54	29	19	4
217-22327	40	15°	M16	23	17	19	14	54	29	19	7
217-22328	50	15°	M24	38	25	28	21	74	34	30	10

SPANNBOLZEN CB FERRARI TIRETTE CB FERRARI
 CB FERRARI PULL STUD CODOLO DI AGGANCIO CB FERRARI
 ТЯНУЩИЕ ШТАНГИ ДЛЯ СТАНКОВ CB FERRARI CB 法拉利拉动式双头螺柱

CB FERRARI

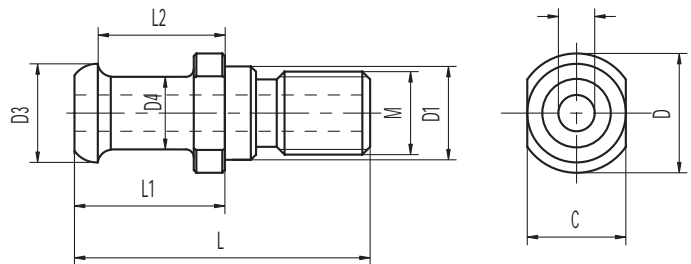

Code N.	ISO	M	D	D1	D3	D4	L	L1	L2	C	F
217-22017	40	M16	23	17	19	15	54	26	20,31	19	5

SPANNBOLZEN CB FERRARI WITH NUT PULL STUD TIRETTE CB FERRARI AVEC ECROU
 JIS. B6339 PULL STUD CODOLO DI AGGANCIO CB FERRARI
 ТЯНУЩИЕ ШТАНГИ ДЛЯ СТАНКОВ CB FERRARI JIS. B6339 拉动式双头螺柱

CB FERRARI

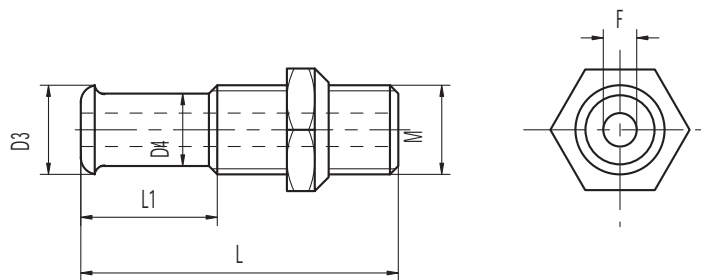

Code N.	ISO	M	D3	D4	L	L1	F
217-22046	40	M16	16	12	57	23	5

SPANNBOLZEN CHIRON TIRETTE CHIRON
 CHIRON PULL STUD CODOLO DI AGGANCIO CHIRON
 ТЯНУЩИЕ ШТАНГИ ДЛЯ СТАНКОВ CHIRON 凯龙拉动式双头螺柱

CHIRON

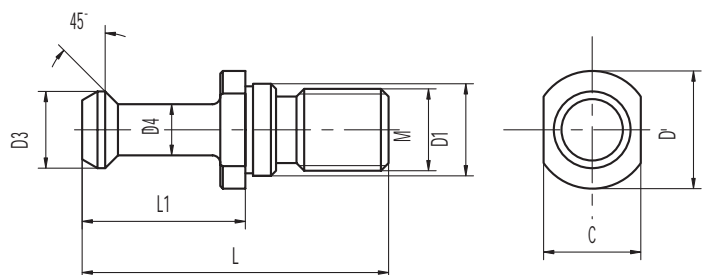

Code N.	ISO	M	D	D1	D3	D4	L	L1	C
217-22048	30	M12	16	13	10	6	36	20	14

SPANNBOLZEN CORREA TIRETTE CORREA
 CORREA PULL STUD CODOLO DI AGGANCIO CORREA
 ТЯНУЩИЕ ШТАНГИ ДЛЯ СТАНКОВ CORREA 科里亚拉动式双头螺柱

CORREA

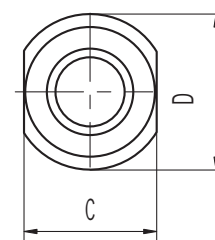
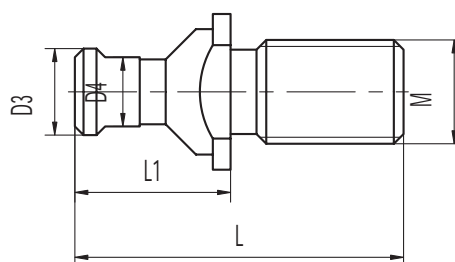

Code N.	ISO	M	D	D3	D4	L	L1	C
217-22135	50	M24	36	20	16	76	36	30

SPANNBOLZEN CORTINI TIRETTE CORTINI
 CORTINI PULL STUD CODOLO DI AGGANCIO CORTINI
 ТЯНУЩИЕ ШТАНГИ ДЛЯ СТАНКОВ CORTINI CORTINI 拉动式双头螺柱

CORTINI

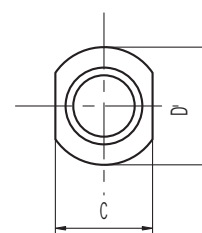
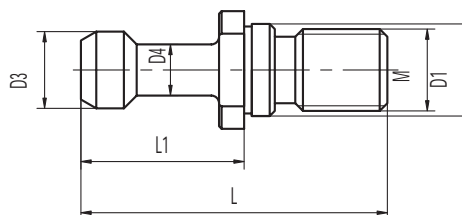

Code N.	ISO	M	D	D1	D3	D4	L	L1	C
217-22254	30	M12	16	13	10	7	39	21	14

SPANNBOLZEN TYP FAMUP TIRETTES TYPE FAMUP
 FAMUP TYPE PULL STUDS CODOLI DI AGGANCIO TIPO FAMUP
 ТЯНУЩИЕ ШТАНГИ ДЛЯ СТАНКОВ FAMUP FAMUP 类型拉动式双头螺柱

FAMUP

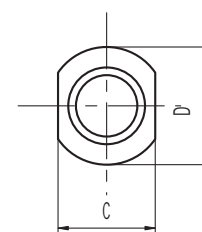
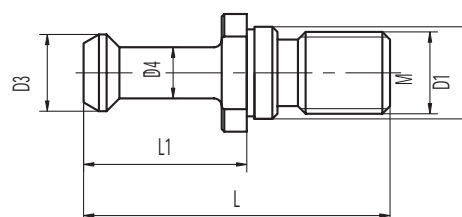

Code N.	ISO	M	D	D1	D3	D4	L	L1	C
217-22137	30	M12	16	13	9,8	5,8	40	20	14
217-22051	40	M16	23	17	13,8	9,8	55	27	19
217-22052	40	M16	23	17	13,8	9,8	58	30	19

SPANNBOLZEN TYP MAZAK TIRETTES TYPE MAZAK
 MAZAK TYPE PULL STUDS CODOLI DI AGGANCIAMENTO TIPO MAZAK
 ТЯНУЩИЕ ШТАНГИ ДЛЯ СТАНКОВ MAZAK MAZAK 型拉动式双头螺柱

MAZAK

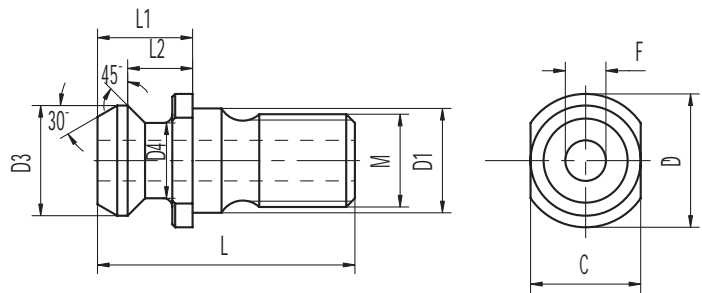

Code N.	ISO	M	D	D1	D3	D4	L	L1	L2	C	F
217-22003	40	M16	21,8	17	18,79	12,44	41,25	16,25	11,17	19	7
217-22047	40	M16	22	17	18,79	12,44	44,10	19,1	14,02	19	7
217-22187	50	M24	35.5	25	28,95	20.8	65.4	25.4	17.78	30	10

Gebohrt • Drilled • Percée • Forato • С отверстием • 钻孔的
 Mit O'Ring • With O'ring • Avec joint torique • Con OR di tenuta • С кольцом • 带O'令

MAZAK

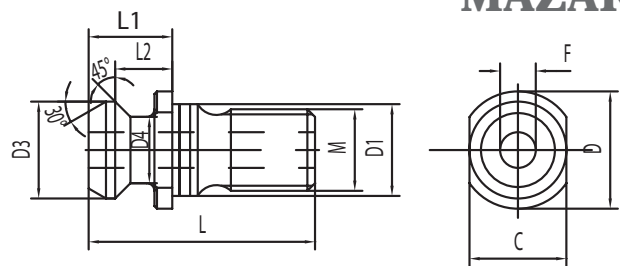

Code N.	ISO	M	D	D1	D3	D4	L	L1	L2	C	F
217-22313	40	M16	21,8	17	18,79	12,44	41,25	16,25	11,17	19	7
217-22314	40	M16	22	17	18,79	12,44	44,10	19,1	14,02	19	7
217-22315	50	M24	35.5	25	28,95	20.8	65.4	25.4	17.78	30	10

SPANNBOLZEN OLIVETTI OCN TIRETTE OLIVETTI OCN
 OLIVETTI OCN PULL STUD CODOLO DI AGGANCIAMENTO OLIVETTI OCN
 ТЯНУЩИЕ ШТАНГИ ДЛЯ СТАНКОВ OLIVETTI OCN OLIVETTI OCN 拉动式双头螺柱

OLIVETTI OCN

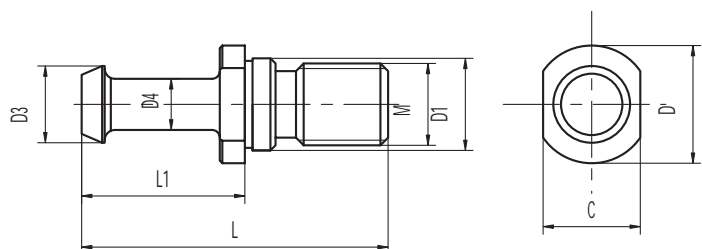

Code N.	ISO	M	D	D1	D3	D4	L	L1	C
217-22136	40	M16	23	17	14,3	10	58	33	19

SPANNBOLZEN TYP RAMBAUDI TIRETTES TYPE RAMBAUDI
 RAMBAUDI TYPE PULL STUDS CODOLO DI AGGANCIO TIPO RAMBAUDI
 ТЯНУЩИЕ ШТАНГИ ДЛЯ СТАНКОВ РАМБАУДИ RAMBAUDI 型拉动式双头螺柱

RAMBAUDI

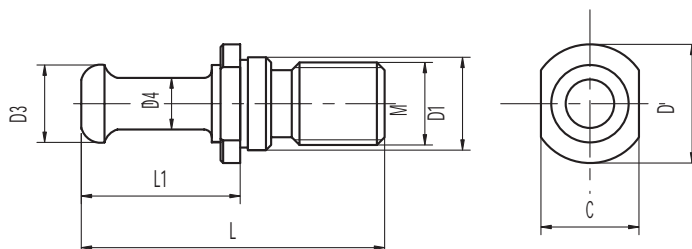

Code N.	ISO	M	D	D1	D3	D4	L	L1	C
217-22049	40	M16	24	17	14,6	10	52	27	19
217-22050	50	M24	35,8	25	20	16	79,5	39,5	30

SPANNBOLZEN BRIDGEPORT TIRETTE BRIDGEPORT
 BRIDGEPORT PULL STUD CODOLO DI AGGANCIO BRIDGEPORT
 ТЯНУЩИЕ ШТАНГИ ДЛЯ СТАНКОВ БРИДЖПОРТ BRIDGEPORT 拉动式双头螺柱

BRIDGEPORT

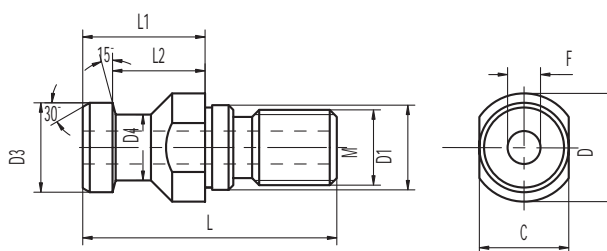

Code N.	ISO	M	D	D1	D3	D4	L	L1	L2	C	F
217-22253	40	M16	23	17	19	14	54	29	23	19	7

SPANNBOLZEN SECMU TIRETTE SECMU
 SECMU PULL STUD CODOLO DI AGGANCIO SECMU
 ТЯНУЩИЕ ШТАНГИ ДЛЯ СТАНКОВ SECMU SECMU 拉动式双头螺柱

SECMU

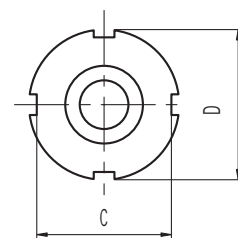
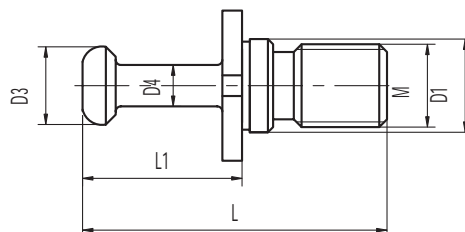

Code N.	ISO	M	D	D1	D3	D4	L	L1	C
217-22138	50	M24	40	25	17,5	9,8	64	29	36

SPANNBOLZEN CINCINNATI TIRETTE CINCINNATI
 CINCINNATI PULL STUD CODOLO DI AGGANCIO CINCINNATI
 ТЯНУЩИЕ ШТАНГИ ДЛЯ СТАНКОВ CINCINNATI 辛辛那提拉动式双头螺柱

CINCINNATI

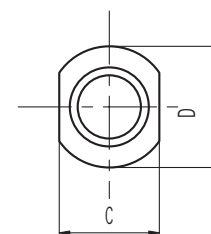
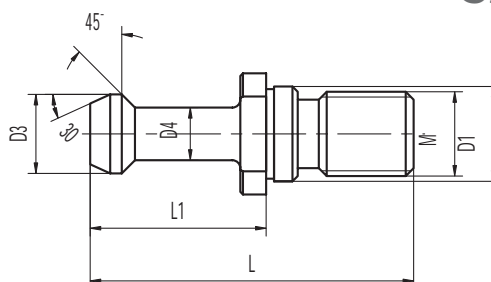

Code N.	ISO	M	D	D1	D3	D4	L	L1	C	F
217-22010	40	M16	22,2	17	15	10,3	67,3	39,4	19	3,8
217-22030	40	M16	22,2	17	15	10,3	67,3	36,6	18	3,8

SPANNBOLZEN BIESSE TIRETTE BIESSE
 BIESSE PULL STUD CODOLO DI AGGANCIO BIESSE
 ТЯНУЩИЕ ШТАНГИ ДЛЯ СТАНКОВ BIESSE BIESSE 拉动式双头螺柱

BIESSE

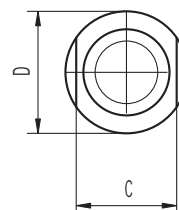
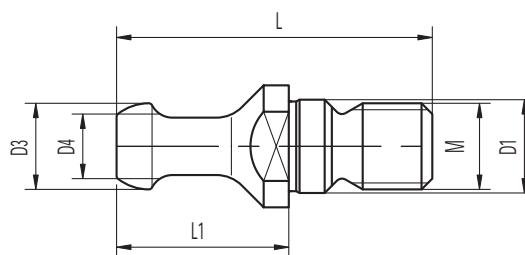

Code N.	ISO	M	D	D1	D3	D4	L	L1	C
217-22158	30	M12	17	13	12	8	44	24	14

KANTENTASTER MECHANISCH PINULE DE CENTRAGE MECANIQUE
 EDGE FINDER MECHANICAL TASTATORE MECCANICO
 ЦЕНТРОИСКАТЕЛИ 偏心式巡边器

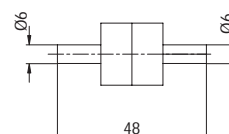
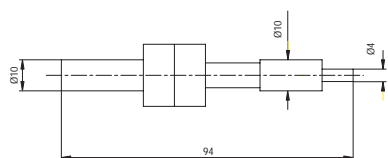
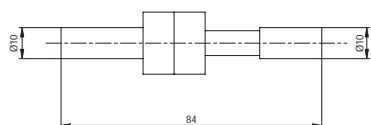

Code N.		L	D
832-021113	10 x 10	84	10
832-021114	10 x 4	94	4

Code N.	ISO	Attack
237-32110	30	DIN 2080
237-32310	40	DIN 2080
237-32510	50	DIN 2080
237-32120	30	DIN 69871
237-32320	40	DIN 69871
237-32520	50	DIN 69871
237-32130	30	MAS 403/BT
237-32330	40	MAS 403/BT
237-32530	50	MAS 403/BT



Dieses unkompliziertes System erlaubt die schnelle und sichere Montage und Demontage von Steilkegelaufnahmen in horizontaler und vertikaler Lage. Das Risiko der Werkzeugbeschädigung ist ausgeschlossen. Dieses einfache und sichere System eignet sich für alle Steilkegelaufnahmen.

It is very useful for all assembly and disassembly operations of the tools on the toolholders, either in horizontal or in vertical position. This process is carried out without any risk to damage casually the tool or the toolholder.

It is a very simple system suitable for monolithic toolholders.

Приспособление очень удобно для операций сборки и демонтажа инструмента, как в вертикальном, так и в горизонтальном положении. Оно позволяет избежать повреждения оправок или режущего инструмента. Это простое приспособление подходит для монолитных оправок.

Il permet d'effectuer toutes les opérations de montage / assemblage / démontage des outils sur les mandrins. Ces proces se déroulent avec rationalité, sureté, vitesse et sans aucun risque d'endommagement accidentel du mandrin ou de l'outil. C'est un système qui offre la plus haute simplicité d'usage et il est bien indiqué pour les mandrin monolitiques.

Consente di effettuare tutte le operazioni di montaggio e smontaggio degli utensili sui mandrini, sia in orizzontale che in verticale. Questi procedimenti avvengono con razionalità, sicurezza, rapidità e senza alcun rischio di danneggiare il mandrino o l'utensile. È il sistema che offre la massima semplicità d'uso per i mandrini monolitici.

它对于所有将工具以垂直或水平方向安装在刀柄上和从刀柄上拆除，均非常有用。这一过程的执行不会对工具或刀柄产生任何破坏的风险。这一非常简单的系统适用于整体式刀柄。

MONTAGEBLOCK SUPPORT D'ASSEMBLAGE
ASSEMBLY SUPPORT ECONOMIC VERSION SUPPORTO DI MONTAGGIO VERSIONE ECONOMICA
УСТРОЙСТВО ДЛЯ СБОРКИ ИНСТРУМЕНТА. ЭКОНОМИЧНАЯ ВЕРСИЯ. 经济型支撑组件



Economic Version

Code N.	ISO	Attack
268-30001	40	DIN 2080/DIN 69871 MAS 403BT / ANSI B5.50 CAT / HSK63A-C-D-E
268-30002	50	DIN 2080/DIN 69871 MAS 403BT / ANSI B5.50 CAT / HSK 100A-C-D-E

SK-SPANNFUTTERSATZ JEUX PORTE-PINCES
 TOOL HOLDERS KIT KIT MANDRINI
 НАБОРЫ ИНСТРУМЕНТАЛЬНЫХ ОПРАВОК 刀柄组套



ISO 40

CODE DIN 69871	CODE MAS 403/BT	CODE DIN 2080	DESCRIZIONE DESCRIPTION	
KIT MAN TC 40	KIT MAN BT 40	KIT MAN ISO 40	N°2 portapinze ER25	N°2 collet chucks ER25
			N°5 portapinze ER32	N°5 collet chucks ER32
			N°1 portafrese fisso D16	N°1 milling arbor D16
			N°1 portafrese fisso D22	N°1 milling arbor D22
			N°1 portafrese fisso D27	N°1 milling arbor D27
			N°1 portafrese weldon Ø16	N°1 side lock holder Ø16
			N°1 portafrese weldon Ø20	N°1 side lock holder Ø20
			N°1 portafrese weldon Ø25	N°1 side lock holder Ø25
			N°1 portapunte/frese CM2	N°1 adaptor mills/drills MT2
			N°1 portapunte/frese CM3	N°1 adaptor mills/drills MT3
			N°1 maschiatore M3-M12	N°1 tap holder M3-M12
			N°5 bussole portamaschi (Ø4.5-6-8-9-10)	N°5 tap adaptors (Ø4.5-6-8-9-10)
			N°10 pinze ER25 (Ø2 3 4 5 6 10 12 14 16)	N°10 collets ER25 (Ø2 3 4 5 6 10 12 14 16)
			N°10 pinze ER32 (Ø3 4 6 8 10 12 14 16 18 20)	N°10 collets ER32 (Ø3 4 6 8 10 12 14 16 18 20)
			N°1 chiave per ER25	N°1 wrench ER25
N°1 chiave per ER32	N°1 wrench ER32			



ISO 50

CODE DIN 69871	CODE MAS 403/BT	CODE DIN 2080	DESCRIZIONE DESCRIPTION	
KIT MAN TC 50	KIT MAN BT 50	KIT MAN ISO 50	N°1 portapinze ER25	N°1 collet chuck ER25
			N°1 portapinze ER25 prolungato	N°1 collet chuck ER25 extended
			N°3 portapinze ER32	N°3 collet chucks ER32
			N°1 portapinze ER32 prolungato	N°1 collet chuck ER32 extended
			N°1 portafrese fisso D22	N°1 milling arbor D22
			N°1 portafrese fisso D27	N°1 milling arbor D27
			N°1 portafrese fisso D32	N°1 milling arbor D32
			N°1 portafrese weldon Ø16	N°1 side lock holder Ø16
			N°1 portafrese weldon Ø20	N°1 side lock holder Ø20
			N°1 portafrese weldon Ø25	N°1 side lock holder Ø25
			N°1 portafrese weldon Ø32	N°1 side lock holder Ø32
			N°1 portapunte/frese CM2	N°1 adaptor mills/drills MT2
			N°1 portapunte/frese CM3	N°1 adaptor mills/drills MT3
			N°1 maschiatore M6-M20	N°1 tap holder M6-M20
			N°5 bussole portamaschi (Ø6 8 10 12 16)	N°5 tap adaptors (Ø6 8 10 12 16)
			N°10 pinze ER25 (Ø2 3 4 5 6 8 10 12 14 16)	N°10 collets ER25 (Ø2 3 4 5 6 8 10 12 14 16)
			N°10 pinze ER32 (Ø3 4 6 8 10 12 14 16 18 20)	N°10 collets ER32 (Ø3 4 6 8 10 12 14 16 18 20)
			N°1 chiave per ER25	N°1 wrench ER25
N°1 chiave per ER32	N°1 wrench ER32			

SPANNFUTTERSATZ JEUX PORTE-PINCES
 COLLET CHUCK KITS KIT PORTAPINZE
 НАБОРЫ ОПРАВОК С ЦАНГАМИ 夹头变径套组套

DIN 6499

Ausstattungskasten : 1 Spannzangenfutter + 10 Spannzangen + Spannschlüssel

Kit Box: 1 Collet chuck + 10 Collets + Wrench

Набор из цангового патрона и цанг

Boite d'équipement: 1 Porte-pince + 10 pinces + Clé de serrage

Cassetta corredo : 1 Portapinze + 10 pinze + chiave



	CODE DIN 2080	CODE DIN 69871	CODE MAS 403 BT	DESCRIZIONE - DESCRIPTION
ISO 30	KIT ISO30ER25	KIT TC30ER25	KIT BT30ER25	N°1 portapinze + 10 pinze ER25 + chiave N°1 collet chuck + 10 collets ER25 + wrench (ER25 Ø 2-3-4-5-6-8-10-12-14-16)
	KIT ISO30ER32	KIT TC30ER32	KIT BT30ER32	N°1 portapinze + 10 pinze ER32 + chiave N°1 collet chuck + 10 collets ER32 + wrench (ER32 Ø 3-4-6-8-10-12-14-16-18-20)
ISO 40	KIT ISO40ER25	KIT TC40ER25	KIT BT40ER25	N°1 portapinze + 10 pinze ER25 + chiave N°1 collet chuck + 10 collets ER25 + wrench (ER25 Ø 2-3-4-5-6-8-10-12-14-16)
	KIT ISO40ER32	KIT TC40ER32	KIT BT40ER32	N°1 portapinze + 10 pinze ER32 + chiave N°1 collet chuck + 10 collets ER32 + wrench (ER32 Ø 3-4-6-8-10-12-14-16-18-20)
	KIT ISO40ER40	KIT TC40ER40	KIT BT40ER40	N°1 portapinze + 10 pinze ER40 + chiave N°1 collet chuck + 10 collets ER40 + wrench (ER40 Ø 5-6-8-10-12-16-20-22-24-26)
ISO 50	KIT ISO50ER25	KIT TC50ER25	KIT BT50ER25	N°1 portapinze + 10 pinze ER25 + chiave N°1 collet chuck + 10 collets ER25 + wrench (ER25 Ø 2-3-4-5-6-8-10-12-14-16)
	KIT ISO50ER32	KIT TC50ER32	KIT BT50ER32	N°1 portapinze + 10 pinze ER32 + chiave N°1 collet chuck + 10 collets ER32 + wrench (ER32 Ø 3-4-6-8-10-12-14-16-18-20)
	KIT ISO50ER40	KIT TC50ER40	KIT BT50ER40	N°1 portapinze + 10 pinze ER40 + chiave N°1 collet chuck + 10 collets ER40 + wrench (ER40 Ø 5-6-8-10-12-16-20-22-24-26)

ZYLINDRISCHE SPANNFUTTER-SATZ
EXTENSION COLLET CHUCKS KITS
НАБОРЫ УДЛИНИТЕЛЕЙ С ЦАНГАМИ

JEUX PORTE-PINCES À QUEUE CYLINDRIQUE
KIT PORTAPINZE CILINDRICI
加长夹头变径套组套



CODICE CODE	DESCRIZIONE DESCRIPTION
KIT PPC-ER16M	<p>N°1 portapinze cilindrici Ø 12x80 ER16M N°1 portapinze cilindrici Ø 16x125 ER16M N°1 portapinze cilindrici Ø 20x160 ER16M N°10 pinze ER16 (Ø 1 2 3 4 5 6 7 8 9 10) N°1 chiave per ER16M</p> <p><i>N°1 extension collet chuck Ø 12x80 ER16M N°1 extension collet chuck Ø 16x125 ER16M N°1 extension collet chuck Ø 20x160 ER16M N°10 collets ER16 (Ø 1 2 3 4 5 6 7 8 9 10) N°1 wrench ER16M</i></p>
KIT PPC-ER20M	<p>N°1 portapinze cilindrici Ø 16x100 ER20M N°1 portapinze cilindrici Ø 20x120 ER20M N°1 portapinze cilindrici Ø 25x160 ER20M N°10 pinze ER20 (Ø 3 4 5 6 7 8 9 10 12 13) N°1 chiave per ER20M</p> <p><i>N°1 extension collet chuck Ø 16x100 ER20M N°1 extension collet chuck Ø 20x120 ER20M N°1 extension collet chuck Ø 25x160 ER20M N°10 collets ER20 (Ø 3 4 5 6 7 8 9 10 12 13) N°1 wrench ER20M</i></p>
KIT PPC-ER25M	<p>N°1 portapinze cilindrici Ø 20x100 ER25M N°1 portapinze cilindrici Ø 25x70 ER25M N°1 portapinze cilindrici Ø 25x120 ER25M N°10 pinze ER25 (Ø 2 3 4 5 6 8 10 12 14 16) N°1 chiave per ER25M</p> <p><i>N°1 extension collet chuck Ø 20x100 ER25M N°1 extension collet chuck Ø 25x70 ER25M N°1 extension collet chuck Ø 25x120 ER25M N°10 collets ER25 (Ø 2 3 4 5 6 8 10 12 14 16) N°1 wrench ER25M</i></p>

KRAFTSPANNFUTTERSATZ JEUX À FORT SERRAGE
MILLING CHUCK KITS KIT FORTE SERRAGGIO
НАБОРЫ СИЛОВЫХ ПАТРОНОВ С ЦАНГАМИ К НИМ 铣夹头组套

Ausstattungskasten: 1 Kraftspannfutter + 1 Spannzensatz + 1 Spannschlüssel

Kit Box: 1 milling chuck + 1 collets kit + 1 wrench

Набор: 1 патрон + 1 набор цанг + 1 ключ

Boîte d'équipement : 1 mandrin à fort serrage + 1 jeux de pince + 1 clé

Cassetta Corredo: 1 mandrino forte serraggio + 1 serie pinze + 1 chiave

组件盒: 1 个铣夹头 + 1 个夹头套装 + 1 个扳手



	CODICE ORDINAZIONE Order Code	COMPOSIZIONE Composition
ISO 40	KIT BT40 C20	N°1 BT40 L105 C20 + n°5 pinze K20: Ø6,8,10,12,16
	KIT BT40 C32	N°1 BT40 L105 C32 + n°7 pinze K32: Ø6,8,10,12,16,20,25
	KIT TC40 C20	N°1 TC 40 L105 C20 + n°5 pinze K20: Ø6,8,10,12,16
	KIT TC40 C32	N°1 TC 40 L105 C32 + n°7 pinze K32: Ø6,8,10,12,16,20,25
	KIT ISO40 C32	N°1 ISO 40 L83 C32 + n°7 pinze K32: Ø6,8,10,12,16,20,25
ISO 50	KIT BT50 C20	N°1 BT 50 L105 C20 + n°5 pinze K20: Ø6,8,10,12,16
	KIT BT50 C32	N°1 BT 50 L105 C32 + n°7 pinze K32: Ø6,8,10,12,16,20,25
	KIT TC50 C20	N°1 TC 50 L105 C20 + n°5 pinze K20: Ø6,8,10,12,16
	KIT TC50 C32	N°1 TC 50 L105 C32 + n°7 pinze K32: Ø6,8,10,12,16,20,25
	KIT ISO50 C32	N°1 ISO 50 L85 C32 + n°7 pinze K32: Ø6,8,10,12,16,20,25

HYDRO-DEHNSPANNFUTTERSATZ JEUX HYDRAULIQUE
 HYDRAULIC KIT KIT IDRAULICO
 НАБОРЫ ГИДРОПЛАСТОВЫХ ПАТРОНОВ С ЦАНГАМИ 液压组套

Ausstattungskasten: 1 Hydro-Dehnspannfutter + 1 Spannzangensatz + 1 Spannschlüssel

Kit Box: 1 hydraulic chuck + 1 collets kit + 1 wrench

Набор: 1 гидропластовый патрон + 1 ключ + 1 набор втулок

Boîte d'équipement : 1 mandrin hydraulique + 1 jeux de pince + 1 clé

Cassetta Corredo: 1 mandrino "idraulico" + 1 serie pinze + 1 chiave

组套箱: 1个液压夹头+1个夹头组套+1个扳手



	CODICE ORDINAZIONE <i>Order Code</i>	COMPOSIZIONE <i>Composition</i>
ISO 40	KIT BT40 G20	N°1 BT40 H90 G20-WO + n°5 pinze GX20: Ø6,8,10,12,16
	KIT BT40 G32	N°1 BT40 H105 G32-WO + n°7 pinze GX32: Ø10,12,14,16,18,20,25
	KIT TC40 G20	N°1 TC40 H80,5 G20-WO + n°5 pinze GX20: Ø6,8,10,12,16
	KIT TC40 G32	N°1 TC40 H110 G32-WO + n°7 pinze GX32: Ø10,12,14,16,18,20,25
ISO 50	KIT BT50 G20	N°1 BT50 H90 G20-WO + n°5 pinze GX20: Ø6,8,10,12,16
	KIT TC50 G20	N°1 TC50 H80,5 G20-WO + n°5 pinze GX20: Ø6,8,10,12,16